

Winter 2010 Issue 17

SCIENCE in SCHOOL

In this issue:

The science of
humour: Allan Reiss

Also:

Stage lights:
physics
and drama



EIROforum

Highlighting the best in science teaching and research

Welcome to the seventeenth issue of *Science in School*



Do men and women share the same sense of humour? Perhaps, but their brains react differently to it, as Allan Reiss explains in this issue's feature article (page 8). Of course, people differ not only in their humour but also in many other ways, including skin colour, hair thickness and the ability to digest starch or lactose. What is the genetic basis of such differences, and could they have been evolutionary adaptations to a changing environment? Jarek Bryk tells us how scientists investigate these questions (page 11).

Once scientists have the genetic data, how do they analyse it? Bioinformatics is an important tool; with Cleopatra Kozłowski's activity you can try some of the techniques yourself, exploring phylogeny with a pen and paper (page 28).

Do you teach physics rather than biology? Then you might like two of this issue's teaching activities: modelling the trajectory of a projectile (page 23), or a laser pen for beaming music across the classroom (page 41). For chemistry teachers, our nanoscale experiments offer an interdisciplinary activity (page 34).

Nanoparticles are also at the heart of cloud formation, as Karin Ranero Celius explains (page 54). The physics of these masses of water droplets or ice crystals is quite complex, and scientists are still learning how clouds and climate influence each other.

Tim Harrison and Dudley Shallcross also have their heads in the clouds: they commemorate the 25th anniversary of the discovery of the hole in the ozone layer by investigating the chemistry of how the hole formed and why it's going to get smaller (page 46). Ice clouds in the stratosphere are at the core of the matter, yet amazingly, even at very low temperatures, clouds can consist of water droplets rather than ice. Tobias Schüllli investigates this phenomenon, known as supercooling (page 17).

Moving even further away from Earth, into space, we enter the realm of astronomers. Marvel with Jochen Liske at huge telescopes in remote places and learn about his involvement in *Das Auge 3D*, a 3D film about the Very Large Telescope in Chile's Atacama Desert (page 60).

Making science visually appealing definitely helps in the classroom – but how do you do this when teaching blind and visually impaired youngsters? Werner Liese shares his experiences in this issue's teacher profile (online). This and several other articles in this issue are available online only – so do visit the *Science in School* website. To learn more about its features, see our new help page: www.scienceinschool.org/help

Finally, don't forget that there are many ways in which you, too, can contribute to *Science in School*. Find out more online: www.scienceinschool.org/information

Marlene Rau

Editor of *Science in School*
editor@scienceinschool.org
www.scienceinschool.org



About *Science in School*

Science in School promotes inspiring science teaching by encouraging communication between teachers, scientists and everyone else involved in European science education.

The journal addresses science teaching both across Europe and across disciplines: highlighting the best in teaching and cutting-edge research.

It covers not only biology, physics and chemistry, but also earth sciences, engineering and medicine, focusing on interdisciplinary work.

The contents include teaching materials; cutting-edge science; interviews with young scientists and inspiring teachers; reviews of books and other resources; and European events for teachers and schools.

Science in School is published quarterly, both online and in print. The website is freely available, with articles in many European languages. The English-language print version is distributed free of charge within Europe.

Contact us

Dr Eleanor Hayes / Dr Marlene Rau
Science in School
European Molecular Biology Laboratory
Meyerhofstrasse 1
69117 Heidelberg
Germany
editor@scienceinschool.org

Subscriptions

Register online to:

- Receive an email alert when each issue is published
- Request a free print subscription (within Europe)
- Swap ideas with teachers and scientists in the *Science in School* online forum
- Post comments on articles in *Science in School*.

Submissions

We welcome articles submitted by scientists, teachers and others interested in European science education. See the author guidelines on our website.

Referee panel

Before publication, *Science in School* articles are reviewed by European science teachers to check that they are suitable for publication. If you would like to join our panel of referees, please read the guidelines on our website.

Book reviewers

If you teach science in Europe and would like to review books or other resources for *Science in School*, please read the guidelines on our website.

Translators

We offer articles online in many European languages. If you would like to volunteer to translate articles into your own language, please read the guidelines for translators on our website.

Advertising in *Science in School* – new lower prices

Science in School is the **only** European journal aimed at secondary-school science teachers across Europe and across the full spectrum of sciences. It is freely available online, and 15 000 full-colour printed copies are distributed each quarter.

The readership of *Science in School* includes everyone involved in European science teaching, including:

- Secondary-school science teachers
- Scientists
- Primary-school teachers
- Teacher trainers
- Science communicators.

Web advertisements

Reach 30 000 science educators worldwide every month.

- € 200-350 per week

Print advertisements

Reach over 15 000 readers per issue.

- Full page: € 1495
- Half page: € 999
- Quarter page: € 560
- Back cover (full page): € 1995

Distribution

Distribute flyers, DVDs or other materials to 3000 named subscribers or to all 15 000 print recipients.

For more information, see www.scienceinschool.org/advertising or contact advertising@scienceinschool.org



8



11



41



54



60

Editorial

Welcome to the seventeenth issue of *Science in School*

Events

- 2 Science on Stage: searching for the best teachers in Europe
- 5 Teachers fly high at the European Space Agency

Feature article

- 8 The science of humour: Allan Reiss

Cutting-edge science

- 11 Human evolution: testing the molecular basis
- 17 Science is cool... supercool

Teaching activities

- 23 Going ballistic: modelling the trajectories of projectiles
- 28 Bioinformatics with pen and paper: building a phylogenetic tree

Projects in science education

- 34 School experiments at the nanoscale
- 41 Stage lights: physics and drama

Science topics

- 46 A hole in the sky
- 54 Clouds: puzzling pieces of climate

Scientist profile

- 60 An astronomer in a 3D world

Additional online material

Teacher profile

Blind date in the science classroom

Reviews

Very Short Introductions to Evolution, Human Evolution and the History of Life

A Private Universe online resources

Resources on the web

Educational resources for the International Year of Biodiversity

See: www.scienceinschool.org/2010/issue17

Forthcoming events for schools: www.scienceinschool.org/events

Science on Stage: searching for the best teachers in Europe

In more than 20 European countries, teachers are sharing their inspiring teaching ideas with colleagues, students and the general public via Science on Stage. **Eleanor Hayes** reviews some of the recent events.

Teachers presenting their ideas in the fair

Image courtesy of Science on Stage Germany



Can physics be experienced at a scale of 1:87? A physics theme park

Image courtesy of Science on Stage Germany



The project 'Radioactivity – curse or blessing?' project addresses the scientific, historic and social aspects of nuclear fission. The origami cranes relate to the book Sadako's story, about a girl who developed leukaemia after the nuclear bomb fell on Hiroshima

Image courtesy of Science on Stage Germany



Alice in Chemistryland

Image courtesy of the Palace of Wonders



Germany: chocolate and soap bubbles

On 1 October 2010, 47 of Germany's most creative science teachers and educators met in Berlin to present their teaching ideas and compete to represent Germany at the Science on Stage international teaching festival in Copenhagen, Denmark, in April 2011^{w1, w2}.

Chemistry teacher Angela Köhler-Krützfeldt and her students, for example, investigated the science of chocolate, while Dieter Legl and Alexander Frisch developed a play: 'The Light at the End of the Tunnel', which took a trip through the human digestive system. Martin Busch and Patrick Woldt's project was similarly creative: their students were 'hired' as trainees in a fictional nanotechnology company, where they learned all about what the job involved. For younger students, Wilfried Meyer developed a workshop in which primary-school children investigated the shapes, sizes, colours and other characteristics of soap bubbles.

Representatives of these and eight other projects were chosen to join about 350 colleagues from across Europe, celebrating the importance of science teaching, under the motto 'Science teaching: winning hearts and minds', at the Science on Stage international festival.

Hungary: drama in science

On 2 October 2010, one room of the Palace of Wonders science centre in Budapest, Hungary, was packed: as many as 300 members of the public arrived to watch the demonstrations, performances and experiments at the Science on Stage Hungary^{w3} festival, opened by the president of the Hungarian Academy of Sciences, József Pálincás.

The audience watched with bated breath as chemistry teacher Endre Szórád set fire to a bank note – without damaging it. (It was soaked in a

50:50 mixture of alcohol and water; as the alcohol burned, the water evaporated, keeping the paper below its ignition point.) Also full of drama was the stage performance by Beáta Jarosievitz's secondary-school students, in which Alice found herself in Chemistryland, and the White Rabbit and his friends guided her through the wonders of chemical reactions. They made ice cream and sorbet using liquid nitrogen, transformed a cup of tea into lemonade and finished the performance with a colourful firework display.

Endre, Beáta and seven other lucky participants were chosen to represent Hungary at the international teaching festival in Copenhagen.

Slovakia: recycling materials for the science classroom

From 4-7 May 2010, the Smolenice Castle echoed with the noise of the Science on Stage Slovakia teaching fair: 50 primary-school, secondary-school and university teachers sharing ideas and inspiration^{w4}.

Peter Horvath, for example, developed ways to teach the moment of inertia of rotating objects, using very simple materials. In one of his demonstrations, he connected CDs together using screws either close to the centre or close to the edge; how did this affect the moment of inertia?

Other activities included simple experiments about the relative humidity of air, electricity and magnetism; a workshop about using coloured wooden blocks to introduce young children to the concepts of torque, centre of gravity and equilibrium; and a presentation about a physics summer camp for children aged 10-15.

The final decision has not yet been made, but representatives of five projects will be heading to Copenhagen in 2011 to share their ideas with their European colleagues.



Image courtesy of Science on Stage Slovakia

Investigating the relative humidity of air

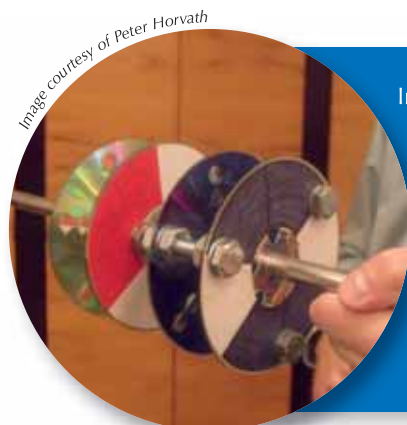

Image courtesy of Peter Horvath

Investigating the moment of inertia using CDs



Image courtesy of Science on Stage Slovakia

How to introduce young children to torque, centre of gravity and equilibrium

Romania: reaching out to the public

For the organisers of the Romanian Science on Stage event^{w5}, it was important to involve the public and raise their awareness of science. For this reason, the event took place in the city centre park in Cluj, attracting 800 members of the public, as well as 200 teachers and 1200 school students from both primary and secondary schools.

Image courtesy of Science on Stage Romania



Olga Riscou's paper project

Image courtesy of Science on Stage Romania



Image courtesy of Science on Stage Romania



From each school, teams of students took turns at their stand, describing and demonstrating their projects to visitors. Olga Riscou's primary-school students, for example, produced their own paper, used it for their paintings – and exhibited the beautiful results on their stand. In the project, Olga and her students were assisted by the science teacher from a local secondary school.

With so many people involved, it was an important event in its own right – a chance for teachers and school students to present their ideas, and for the general public to see some of the exciting science that is being done in Romanian schools. In addition, a small number of particularly inspiring projects were selected to attend the Science on Stage international teaching festival in Copenhagen.

Among the lucky winners was Laszlo Papp, whose students built a model of Lake Ursu in Transylvania,

central Romania, which simulated both the flow of water through the lake and the heliothermic phenomenon that occurs in saline lakes, causing the water further down to be warmer than at the surface. Other winning projects included Olga's paper project, Corina Toma's Jacob's Ladder, in which a high-voltage electric current climbed two brass rods, Monica Vascan's impressive model of the kidney and Dana Fenesan's project about biology and chemistry used in traditional farms in the Carpathian mountains.

Attending the international festival

At each national Science on Stage event, a fixed number of teachers are selected to represent their country at the international Science on Stage festival in Copenhagen. For these teachers, participation will be free.

For other science teachers who wish to attend the international festival, there are a limited number of places for which a registration fee will be charged. See the Science on Stage website for details^{w6}.

Web references

- w1 – To find out more about Science on Stage Europe and to contact your national organisers, see: www.science-on-stage.eu
- w2 – To learn more about Science on Stage Germany, see: www.science-on-stage.de
- w3 – For more information about Science on Stage Hungary, see: www.szinpadon-a-tudomany.hu

w4 – To find out more about the Science on Stage Slovakia event, see: www.science-on-stage.sk

w5 – For more information about Science on Stage Romania, see: www.isj.ro/scienceonstage

w6 – To learn more about the international festival and how to apply to take part, see: <http://science-on-stage.eu/?p=3>

Resources

After each of the previous international Science on Stage festivals (and the Physics on Stage festivals that preceded them), the Irish delegates produced a book describing how to carry out their favourite experiments in the festival. These books can be downloaded free of charge from the Science on Stage Ireland website: www.scienceonstage.ie/resources.html

To view all other *Science in School* articles about Science on Stage, see: www.scienceinschool.org/sons

A working model of Lake Ursu in Sovata

Image courtesy of Science on Stage Romania

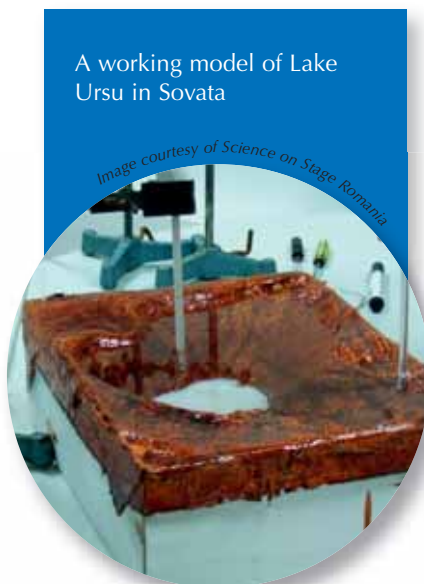

Dr Eleanor Hayes is the editor-in-chief of *Science in School*. She studied zoology at the University of Oxford, UK, and completed a PhD in insect ecology. She then spent some time working in university administration before moving to Germany and into science publishing, initially for a bioinformatics company and then for a learned society. In 2005, she moved to the European Molecular Biology Laboratory to launch *Science in School*.



Teachers fly high at the European Space Agency

Eleanor Hayes reports on the recent teacher workshop at the European Space Research and Technology Centre.

In June 2010, I was delighted to be invited to take part in the European Space Agency's first human space-flight teacher workshop at the European Space Research and Technology Centre (ESTEC) in the Netherlands. Not only did I enjoy the contact with many enthusiastic European science teachers – the target audience of *Science in School* – but I was able to take part in some fascinating workshops.

'What are the obstacles to Martian exploration?' asked Anupam Ojha, physics teacher and director of education at the UK's National Space

Centre. He asked us to consider the best route from Earth to Mars (not the shortest one) and what the many challenges of the Martian environment are. Did you know, for example, that at the very low atmospheric pressure on Mars, your blood would boil instantly at well below body temperature? Or that the force of the air rushing out of your lungs could knock your front teeth out? No wonder Mars explorers will need space suits!

Over the course of 90 minutes, Anu took us on a dizzying tour of the interplanetary and Martian environment – with the aid of hypodermic syringes, marshmallows, liquid nitrogen, an orange and other basic materials. The emphasis of his workshop was to show how the topic of space can be used to teach science. At the end of the day, each teacher received

Image courtesy of Anneke Le Floch / ESA



Teachers building their own radios

a memory stick full of pictures, teaching ideas and other useful resources.

In the neighbouring room, a further group of 20 teachers was learning how to assemble a radio – and receive signals from local radio stations. "This is the first time I have ever soldered anything!" commented several of the teachers.

The Melas Chasma, part of the huge Valles Marineris rift valley on Mars

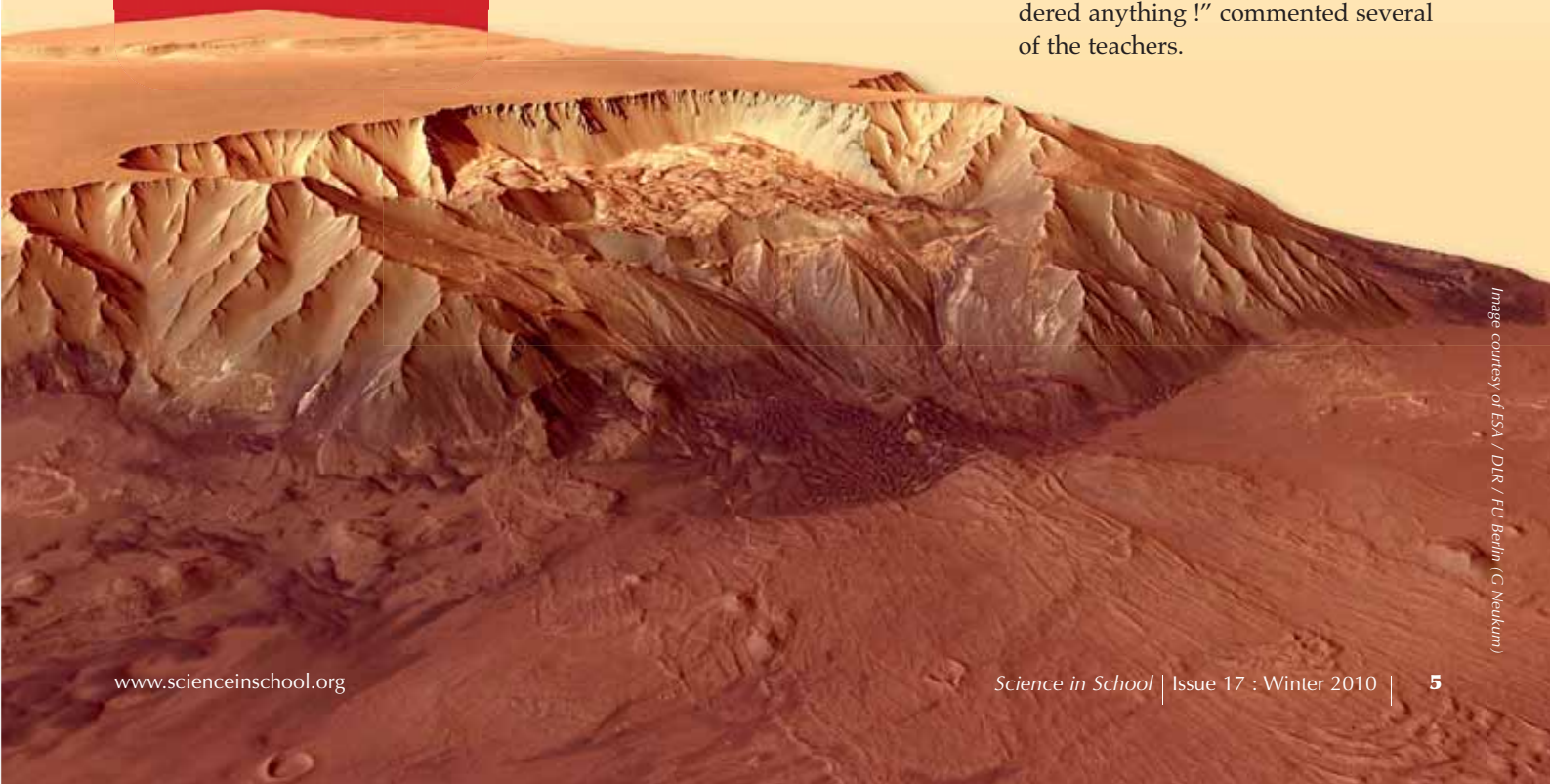



Listening to teachers

Shamim Hartevelt-Velani explains why ESA values the involvement of teachers.

In my work – as a teacher working in the human spaceflight education department at ESA – it has always been important to listen to what teachers want. This workshop was one such opportunity, when we brought together 40 enthusiastic teachers from 18 member states of ESA. Not only did we immerse them in three days of hands-on activities, we also introduced them to some of the education materials that we have developed at ESA, and discussed how they could be used in the classroom.

The teachers were able to provide us with useful feedback on some of the educational resources such as the DVD *Feeding our Future – Nutrition on Earth and in Space*^{w3}, the educational game ‘Spaceflight Challenger 1’^{w4} and the competition ‘Take your classroom into space’ (see Patterson, 2009).

During the workshop, the teachers also suggested possible future demonstrations and experiments that could be done on the International Space Station by the astronauts, similar to the outcome of the ‘Take your classroom into space’ competition – which was very successful in engaging students and teachers from all over Europe. We’re even investigating how the students themselves can get involved in future: carrying out space experiments in short educational films.

The feedback we continue to receive from our workshop participants and other teachers helps us to improve our materials and gives us new ideas about what teachers need to assist them in making science teaching more innovative and interesting to students. It also illustrates that the workshop was the exciting beginning of an iterative process of sharing and collaboration between teachers and the ESA human spaceflight education group.

BACKGROUND

Image courtesy of Carmen Guerra



Teachers Bernhard Sturm (left) and Javier Mendez inside a replica of the Columbus module of the International Space Station

Later that afternoon, a panel led an animated discussion about how to use students’ enthusiasm for space to engage them in science lessons. One of the outcomes of the discussion was a new thread in the *Science in School* online forum^{w1} – in which teachers can share their space-related teaching materials with other *Science in School* readers.

Later, the teachers met one of ESA’s astronauts, Frank De Winne, who described some of the highlights of his OasISS mission as well as his role in the educational projects on the International Space Station (ISS). Being able to talk to Frank informally and ask questions about his work was one of the high points of the workshop.

For both the teachers and ESA, the workshop was a big success – and there will be another one in Summer 2011. Why not apply to participate? Keep watching the ESA Human Spaceflight website^{w2} for details.

References

Patterson L (2009) A classroom in space. *Science in School* **12**: 50-54. www.scienceinschool.org/2009/issue12/spaceclassroom

To find out more about the 'Take your classroom into space' competition, see: www.esa.int or use the direct link:

<http://tinyurl.com/2cpk4sq>

The 'Take your classroom into space' education kit can be ordered online here: <http://esa-hme-education.org>

Web references

w1 – To join the discussion about how to use space to teach science, visit the *Science in School* discussion forum: www.scienceinschool.org/forum/esahs

w2 – To find out when the next teacher workshop will be, and to learn about the wealth of materials developed by the ESA Human Spaceflight education department, see:

www.esa.int/esaHS/education.html

For details of many more education materials produced by ESA, see www.esa.int/educationmaterials

All education materials produced by ESA are freely available to teachers in the 18 ESA member states. Many are translated into several European languages.

w3 – *Feeding our Future – Nutrition on Earth and in Space* examines food as a vital part of life on Earth and in

space. To order a free DVD or download the video (available with subtitles in 13 European languages), see: www.esa.int or use the direct link: <http://tinyurl.com/262fl52>

w4 – Become an astronaut on the International Space Station. 'Spaceflight Challenge 1' features science topics from across European secondary-school curricula. To find out more about this role-playing game, see: www.esa.int or use the direct link: <http://tinyurl.com/39tvgsy>

Resources

Below is a selection of space-related articles previously published in *Science in School*.

Hartevelt-Velani S, Walker C, Elmann-Larsen B (2008) The International Space Station: life in space. *Science in School* **10**: 76-81 www.scienceinschool.org/2008/issue10/iss

Hartevelt-Velani S, Walker C (2008) The International Space Station: a foothold in space. *Science in School* **9**: 62-65. www.scienceinschool.org/2008/issue9/iss

Wegener A-L (2008) Laboratory in space: interview with Bernardo Patti. *Science in School* **8**: 8-12. www.scienceinschool.org/2008/issue8/bernardopatti

Williams A (2008) The Automated Transfer Vehicle – supporting Europe in space. *Science in School* **8**: 14-20. www.scienceinschool.org/2008/issue8/atv

Warmbein B (2007) Down to Earth: interview with Thomas Reiter. *Science in School* **5**: 19-23. www.scienceinschool.org/2007/issue5/thomasreiter

For a complete list of ESA-related articles, see:

www.scienceinschool.org/esa

To browse all space-related articles in *Science in School*, see:

www.scienceinschool.org/space

Dr Eleanor Hayes is the editor-in-chief of *Science in School*. She studied zoology at the University of Oxford, UK, and completed a PhD in insect ecology. She then spent some time working in university administration before moving to Germany and into science publishing, initially for a bioinformatics company and then for a learned society. In 2005, she moved to the European Molecular Biology Laboratory to launch *Science in School*.

Shamim Hartevelt-Velani is a secondary-school teacher currently working under contract at ESTEC, in the Directorate of Human Spaceflight. She is the didactics specialist in the education group.



A perspective view of the Hebes Chasma, obtained by the High Resolution Stereo Camera (HRSC) on ESA's Mars Express spacecraft

Image courtesy of lisegagne / iStockphoto



Image courtesy of Allan Reiss



Allan Reiss

The science of humour: Allan Reiss

Men and women react differently to humour. Allan Reiss tells **Eleanor Hayes** why this is news.

Imagine suddenly losing all voluntary control of your muscles, collapsing in a heap on the ground. Being conscious but temporarily unable to move. This is cataplexy, a phenomenon that, in some people, can be triggered by strong emotions. It is also what first got Allan Reiss interested in studying humour in 2002.

Allan, a professor of psychiatry and behavioural science at Stanford University, USA, initially wanted to investigate what happens in the brain

when someone suffers a cataplectic attack. He knew that attacks could be triggered by strong emotions such as anger or sexual arousal, but was surprised to learn from a colleague, Emmanuel Mignot, that the most important trigger is humour.

However, before Allan and his team began investigating how humour could induce a cataplectic attack, they needed a baseline – they needed to see how humour affects people in normal circumstances.

What happens inside your brain when you find something funny?

Using advanced brain imaging, it is possible to see inside the head, to measure changes in different parts of the brain. The scientists therefore put healthy volunteers into a functional magnetic resonance imaging (fMRI) machine and showed them cartoons. During the brain scan, the volunteers noted whether they found each cartoon funny or not. Afterwards, they gave each cartoon a score from 0-10 on a funniness scale.

“To create the unfunny cartoons, we took funny cartoons and changed them to spoil the joke. I was fascinated by what very small changes were necessary – changing just one word in the caption could make the difference between a hilarious cartoon and a totally unfunny one.”

When the volunteers saw a funny cartoon, the scientists were able to detect changes to several parts of the brain. In particular, brain regions involved in language and executive processing – organising information – were activated. Given that many of the cartoons had captions, this was not unexpected.

However, Allan and his colleagues wanted to see not only how the human brain reacts to humour, but also whether there were differences in the responses of men and women. They therefore used both male and female volunteers.

So do men and women have a different sense of humour? “Not exactly, no. Men and women rated the same number of cartoons as funny, and they also rated the funniness [0-10] of the cartoons similarly. When we looked at the changes within the brain, though, the picture was rather different.”

When exposed to funny cartoons, women showed higher activity of the language and organisation regions of the brain than men. “That was no real surprise. We know that men and women’s brains are different, and it’s

already been shown that, for certain types of task, women use these regions of the brain more than men do.

“What *was* unexpected was a difference in the mesolimbic reward region of the brain: the funny cartoons stimulated this part of the brain much more in women than in men.” The mesolimbic reward region is associated with happiness: seeing beautiful faces, cocaine-induced euphoria and other ‘positive’ stimuli. “The male and female volunteers said they found the cartoons equally funny, so this difference in brain activity seems to have more to do with their expectations than their actual experiences.”

This could be explained by what are known as dopaminergic neurons – a group of nerve cells that respond not to reward as such, but to the difference between the reward you were expecting and what you actually get. Before the experiments, all the volunteers had been told that they were going to be shown 80 cartoons, only some of which would be funny. It

Reprinted from *Neuron* 40(5), Mobbs D et al. *Humor modulates the mesolimbic reward centers*, 1041-1048, © 2003, with permission from Elsevier

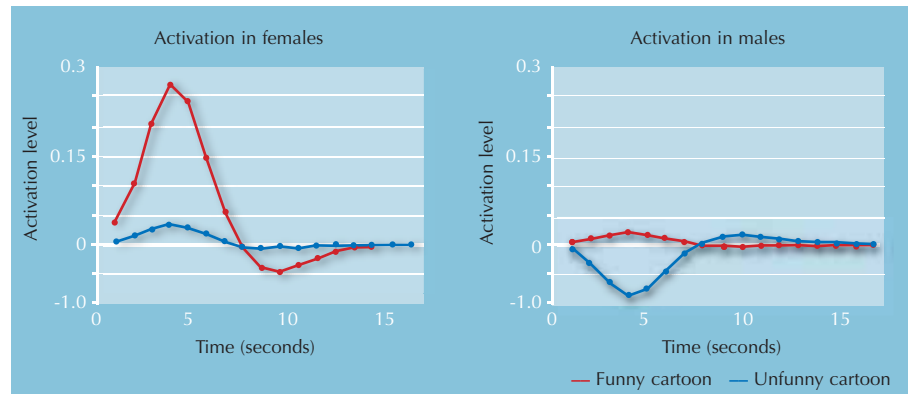

Brain activation in males and females

seems that the male volunteers had higher expectations: they expected to be amused. The women, however, were more cautious – and thus, more pleasantly surprised by the funny cartoons. The reactions to the unfunny cartoons also fitted this explanation: the unfunny cartoons caused the mesolimbic reward region of the brain to be deactivated in men (they didn't get the expected reward), whereas in women there was little or no activity (they were not expecting to be amused; see graph).

At this point, I can't resist asking what Allan's interpretation of the data is. Did the men really have higher expectations than the women? What if they simply hadn't listened to the instructions? With a laugh, he agreed that there are many possible interpretations of the demonstrated differences in brain activation.



- ✓ Biology
- ✓ Neurobiology
- ✓ Ages 16+

Do men and women react differently to humour? Do boys have a different sense of humour or do girls understand jokes better? This could be an interesting project for students in a biology class. Reading this article should help students to think about possible humour-related differences between the sexes and how they could be studied.

Who would have thought that there is actually a science of humour!

Andrew Galea, Malta

REVIEW

Images courtesy of slowgogo / iStockphoto





Image courtesy of Stalman / iStockphoto

I ask Allan what the next steps will be for him and his colleagues. "We'd like to see how early this gender difference appears, so we're going to do the same type of experiment with young children, ages six to ten." In preparation for this experiment, Allan and his colleagues (with the help of lots of young children) have been scouring the online video collection YouTube for funny video clips. The scientists want to look not only for gender differences, but also for differences that depend on the type of reward – does the brain react differently to funny videos (e.g. a child trying to hit a balloon with a stick and accidentally hitting his father) and to other 'rewarding' videos (e.g. lots of cute puppies or a child scoring the winning goal in a football match)? "It's been surprisingly difficult to find videos that are not funny but nonetheless equally rewarding in other ways: the children rate humour above anything else we can find," Allan comments.

I point out to Allan that most of the readers of *Science in School* teach neither adults nor young children – our readers teach mostly teenagers. If he had a class of 15-year-olds to experiment on, what would he like to find out?

"Puberty is a momentous time. It's not only the body that's changing –

there are huge changes going on in the brain. And that affects humour too: what a 10-year-old finds funny is very different to what a 16-year-old does. It could be interesting to investigate those changes at the level of the brain."

Finally, if a class of 15-year-olds wanted to *do* an experiment on humour at school, what would he recommend?

"Well, they could investigate just that: what sort of humour appeals to different ages. They could give students in each year in their school a choice of cartoons and get them to say which they find funniest. Or ask each class for their favourite jokes and then categorise the jokes into different types of humour and see if this changes with age."



Scientific research often leads us off at a tangent; Allan began researching cataplexy and ended up doing rather a lot of research on humour instead. It occurs to me after the interview that I never even asked if he ever did the experiments on humour in cataplectic people. A quick search on the Internet shows that he did, but I'll let you read that paper for yourselves (Reiss et al., 2008).

References

Reiss AL et al. (2008) Anomalous hypothalamic responses to humor in cataplexy. *PLOS One* **3**(5): e2225. doi: 10.1371/journal.pone.0002225
This article, like all articles in *PLOS One*, is freely available from the journal's website: www.plosone.org

Resources

At ESOF, the Euroscience Open Forum, in July 2010, Allan Reiss described some of his research. To watch the video, see the video collection on the ESOF website (www.esof2010.org/webesof) or use the direct link: <http://tinyurl.com/3ynca4s>

Azim E et al. (2005) Sex differences in brain activation elicited by humor. *Proceedings of the National Academy of Science of the USA* **102**(45): 16496-16501. doi: 10.1073/pnas.0408456102

This article is available freely from the journal's website: www.pnas.org

Mobbs D et al. (2003) Humor modulates the mesolimbic reward centers. *Neuron* **40**(5): 1041-1048. doi: 10.1016/S0896-6273(03)00751-7

This article is available freely from the journal's website: www.cell.com/neuron

Schultz W (2002) Getting formal with dopamine and reward. *Neuron* **36**(2): 241-263. doi: 10.1016/S0896-6273(02)00967-4

This article is available freely from the journal's website: www.cell.com/neuron

Schultz W, Tremblay L, Hollerman JR (2000) Reward processing in primate orbitofrontal cortex and basal ganglia. *Cerebral Cortex* **10**: 272-283. doi: 10.1093/cercor/10.3.272

This article is available freely from the journal's website: <http://cercor.oxfordjournals.org>

If you enjoyed this article, you might like to browse other feature articles in *Science in School*. See: www.scienceinschool.org/features

Dr Eleanor Hayes is the editor-in-chief of *Science in School*. She studied zoology at the University of Oxford, UK, and completed a PhD in insect ecology. She then spent some time working in university administration before moving to Germany and into science publishing, initially for a bioinformatics company and then for a learned society. In 2005, she moved to the European Molecular Biology Laboratory to launch *Science in School*.



Human evolution: testing the molecular basis

In the second of two articles, **Jarek Bryk** describes how scientists dig deep into our genes – to test the molecular basis of an evolutionary adaptation in humans.

Images courtesy of Henrik5000/ iStockphoto



- ✓ Biology
- ✓ Genetics
- ✓ Biochemistry
- ✓ Ages 16+

Despite all our knowledge of the sequence of the human genome, the precise function of huge segments of it and how and why DNA sequences have changed within populations remain largely undiscovered. Evolutionary adaptation in humans has obviously occurred but it is very hard to demonstrate. This article describes how one such change has been identified. Experiments with genetically modified mice have demonstrated how a single base change in the DNA, which changes the amino acid sequence of the protein, leads to an alteration in the structure and function of a protein. This can result in phenotypic variation.

In science lessons, the article could be used when addressing the topics of codon usage and degeneracy; protein structure and function; and population genetics. It could also be used as background reading on

variation in the human population or as a starting point for investigating the Sanger Institute and the Human Genome Mapping Project.

The students could discuss evolutionary advantage, with reference to the particular variation described in the article. This could lead on to a discussion of selection, population genetics and Hardy-Weinberg equilibrium. To complement this discussion, there is an excellent activity in Issue 6 of *Science in School* (Pongsophon et al., 2007).

Suitable comprehension questions include:

1. In your own words and giving an example that is not in the text, describe what a SNP is.
2. Explain the significance of SNPs.
3. Which amino acid does the nucleotide triplet GTT code for?
4. Describe the changes that were found in the mice with a genetically modified EDAR pathway, and suggest ways in which the observed changes could be quantified.

Shelley Goodman, UK

The DNA of every organism holds information about its recent and ancient evolutionary history. By studying the patterns and changes in the DNA sequence – comparing the sequences between different individuals or species – we can uncover what has happened to them. We can find out which genes or fragments of the **genome** are likely to have provided an advantage to those individuals and species that carried them, allowing for their better survival and reproduction (see glossary for all terms in bold).

In a previous article (Bryk, 2010), I described a few examples of such beneficial genetic changes in humans and other organisms. Demonstrating which genetic changes might have been beneficial is difficult – especially in humans – but an even greater challenge is demonstrating the *mechanism* by which these changes could have improved the organisms' survival and reproduction.

In this article, I present one of the approaches that scientists can use first to identify regions of our genome that *could have* helped us survive and reproduce, and then to test *how* these regions might have provided our ancestors with an advantage.

One of the ways potentially beneficial regions of our genome can be identified is simply by comparing DNA sequences of many individuals from different populations. In a very simple scenario, if one of these populations has been under **selective pressure** (for example, high UV radiation in a sunny region) that was absent in the other populations, the DNA sequence responsible for an appropriate adaptation (for example, a darker skin colour) should be different.

In the vast majority of cases, however, we do not know what selective pressures populations were exposed to in the past, or which genetic sequences are responsible for the adaptations. Let us begin, therefore, by comparing DNA sequences between human populations without any assumptions about what we may find. Figure 1 shows one such comparison, for a single nucleotide of the human genome.

When individuals have different nucleotides at a particular position in the DNA sequence, we call this a *single nucleotide polymorphism* (SNP, pronounced 'snip'); three million such variants of the human genome are catalogued in the publicly available

HapMap database^{w1}. The SNP in Figure 1, rs3827760, is found in two variants or **alleles**: at that point in the sequence, one of two bases may be found – either thymine (T) or cytosine (C).

Each circle in the figure represents a single population, and depicts the frequency in that population of the two possible alleles.

The thymine-containing allele is present in all African and most European samples, but is almost completely absent in East Asia and the Americas, where cytosine is most prevalent at that position in the sequence (Sabeti et al., 2007, 2006; Xue et al., 2009).

If we did this comparison for all the other three million SNPs from the HapMap we would see that the distribution of rs3827760 variants among human populations is very unusual. Thus rs3827760 definitely deserves a more detailed look, even though the distribution does not tell us anything about the potential benefit of the variants (their **adaptive value**), or even whether they are adaptive at all. All we know so far is that for some reason, the original thymine that was present at this position in ancestral

Adapted with permission from Macmillan Publishers Ltd: Nature, Sabeti et al. (2007), © 2007



Image courtesy of Jarek Bryk

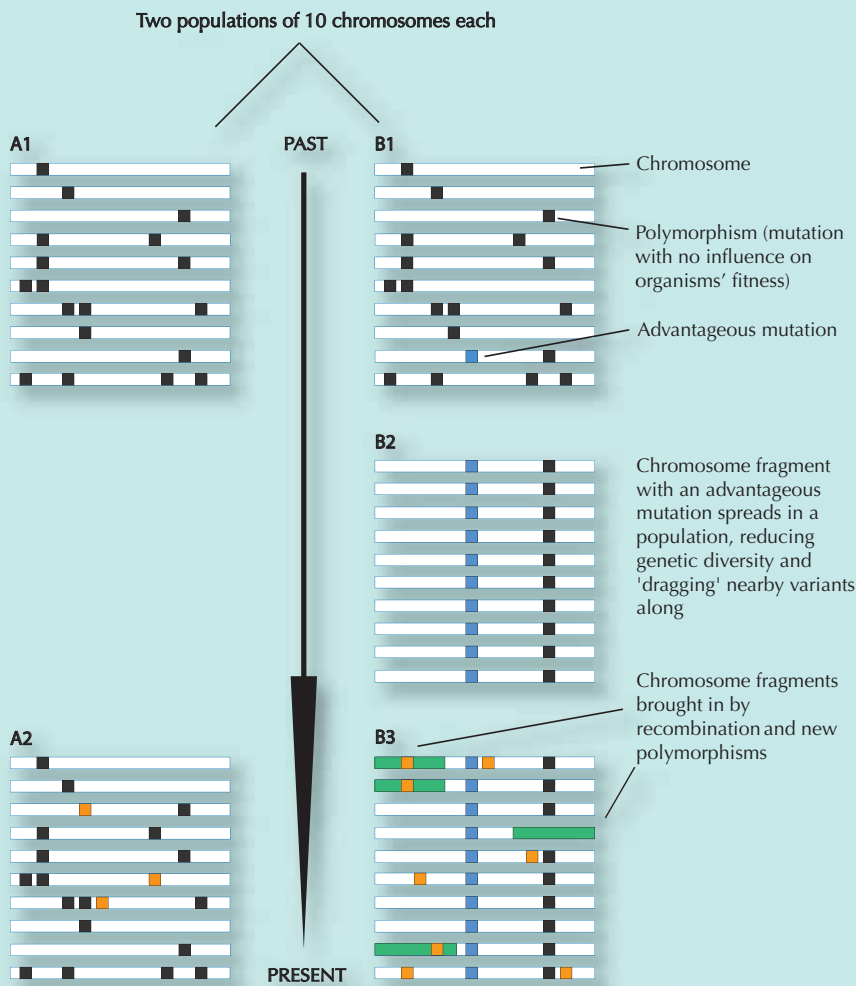

Figure 2: Panels A1, A2 and B1-B3 each illustrate 10 individuals sampled from each of two populations of the same species. For each individual, one chromosome is shown (e.g. chromosome 9). Population A does not experience positive selective pressure and remains relatively unchanged over time, apart from acquiring some random genetic changes that do not influence fitness (orange squares in panel A2; variants which reduce fitness are removed from the population) – compare panels A1 and A2.

Population B moves to a new environment, however, where it faces new selective pressures. In that new environment, a particular genetic change (the blue square on panel B1) provides an advantage to the individuals carrying it and spreads quickly through the population (individuals carrying it leave more offspring). The genetic variants close to the selected SNP get dragged along with it (the closer two variants are, the smaller the chance that they will be separated during recombination, when parts of the DNA are exchanged between maternal and paternal chromosomes – see Figure 3).

The result of this rapid spread of a DNA sequence through the population is a reduction in genetic diversity in that region; most individuals will have the advantageous SNP, together with the genetic variants close to it (compare panels B1 and B2). This process happens quickly.

After some time, however, new genetic changes and recombination events introduce new variants (green rectangles and orange squares in panel B3). The longer the time since the spread of the original selected variant, the more difficult it is to detect, because the pattern of reduced diversity (B2) will eventually be masked (B3)

human populations in Africa changed to cytosine, and that this change spread through East Asians and Americans. Even the estimates of when this change happened are very imprecise: somewhere between 1000 and 70 000 years ago, all individuals in East Asian populations had the cytosine variant.

How, then, can we decide whether this pattern arose due to **positive selection** (cytosine conferred an advantage in East Asia and the Americas) or is simply due to chance?

To see whether the DNA change (thymine to cytosine) was positively selected, we look at the DNA sequence *around* the SNP. If the DNA sequence surrounding rs3827760 were similar in all populations, we would have no evidence that the SNP had an effect on the organism's **fitness**. If, however, one population (East Asian, for example) were exposed to a selective pressure and rs3827760 contributed to the development of adaptation to that selective pressure, DNA sequences around the SNP would dif-

fer between populations. To understand why that is, see Figure 2.

When the DNA sequences around rs3827760 are compared, it becomes obvious that the diversity around the cytosine variants in the East Asian populations is indeed much lower than the diversity around the thymine variants found in the African and European populations (the Americans were not tested). This suggests that positive selection was responsible for the cytosine variant spreading in the East Asian populations. But was this

SNP really selected – does it in fact do anything?

Not all changes to the DNA sequence have an effect on protein sequences: most of the SNPs catalogued in the HapMap database either are located in the non-coding parts of the genome (e.g. between genes) or are synonymous – that is, they are located in the coding part of the genome but do not cause a change in the protein sequence encoded (see Figure 4).

In the case of rs3827760 we are lucky, because it is located in the coding part of a gene – towards the end of a gene called EDAR, which is involved in the development of hair follicles, sweat glands and teeth. Furthermore, the thymine-to-cytosine DNA sequence change results in a change in the protein sequence: Africans and Europeans (carrying the SNP variant with thymine) have the amino acid valine at position 370 of the protein, whereas East Asians and Americans (with the nucleotide cytosine) have the amino acid alanine. This part of the protein is involved in interactions with other proteins, and mutations there are known to cause ectodermal dysplasias – abnormal development of the teeth, hair and sweat glands – in humans and mice (see Figure 5). This fact strongly suggests that an amino acid change at position 370 may not only change the sequence of the protein but also how the protein behaves, affecting the physical characteristics of the organism itself.

To see whether the change in protein sequence really does affect its function, we turn to experiments on the biochemical pathway in which the EDAR protein takes part: a series of reactions which are involved in the development of hair follicles, sweat glands and teeth. When these reactions were carried out in the laboratory, the alanine variant of the protein (found in East Asians and Americans, encoded by the cytosine SNP variant)

Image courtesy of Nicola Graf

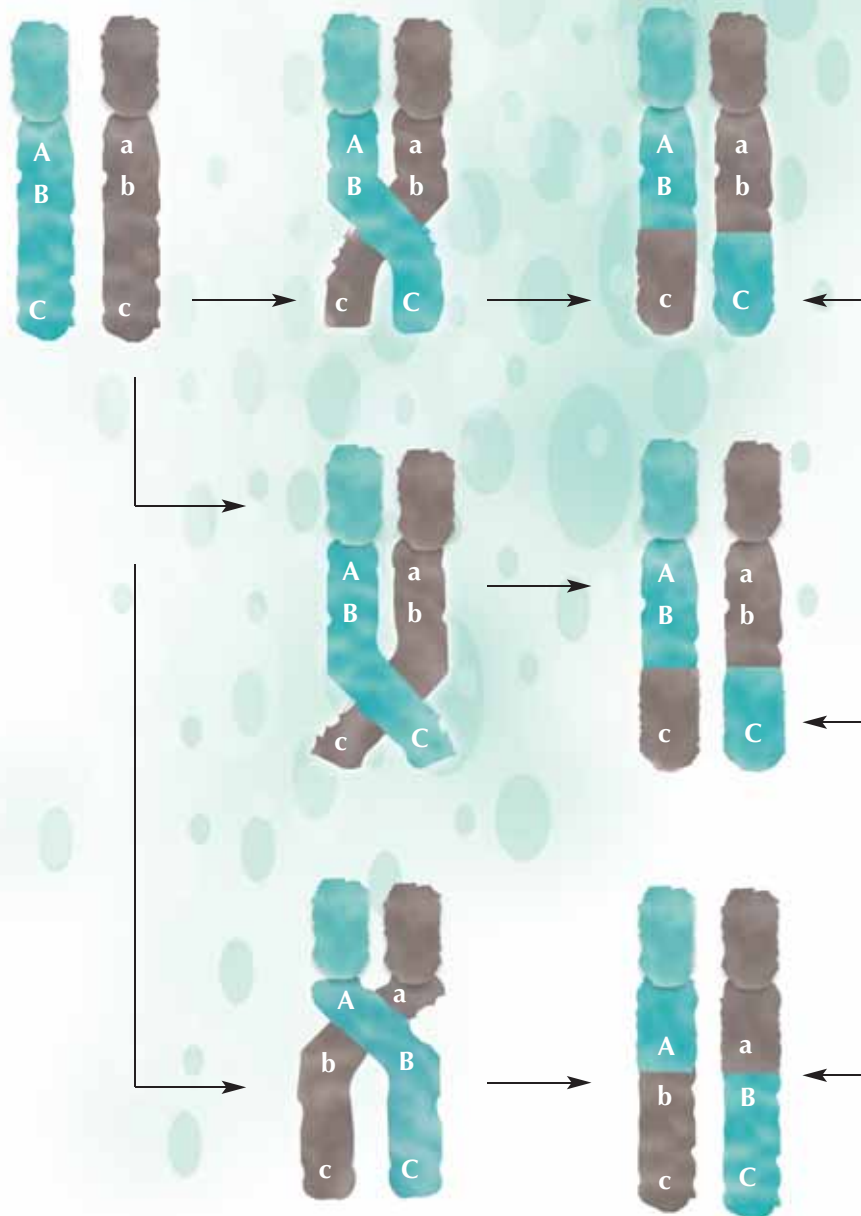

Figure 3: During recombination, parts of the DNA are exchanged between maternal (green) and paternal (grey) chromosomes and passed on to the next generation in a new configuration. The closer two regions are together, the less likely they are to be separated during recombination: A and B are closer together than B and C, thus are less likely to be separated

was found to make the pathway more active than the valine variant (found in Africans and Europeans, encoded by the thymine SNP variant) did. This ties in with comparisons of hair structure, which show that people with the alanine variant have thicker hair than

people with the valine variant. For a more direct demonstration, mice were genetically modified to increase the activity of the EDAR pathway. These mice had visibly denser fur with thicker hair, as well as larger salivary glands, than mice with normal EDAR

Image courtesy of Jarek Bryk

	SNP1	SNP2	SNP1	SNP2
DNA	GAGAAAGCTGTTGTGAAAACG	CTCTTCCGACAACTTTTGC	GAGAAAGCTGCTGTGAAAACG	GAGAAAGCTGCTGTGAAAACG
mRNA	GAGAAGGCUUUUGAAAACG		GAGAAAGCUGCUGUGAAAACG	
protein	GluLysAlaValValLysThr		GluLysAlaAlaValLysThr	
	Original sequence		Mutated sequence	

Figure 4: Not all changes to the coding DNA sequence cause a change in the encoded protein sequence. In this example, replacing guanine (G) with adenine (A) in the codon AAG makes no change to the protein: both AAG and AAA encode the protein lysine (SNP 1). This is known as a synonymous mutation.

In the case of the SNP rs3827760 (SNP 2 in this figure), thymine (T) is replaced with cytosine (C) in the codon GTT. Changing the codon from GTT to GCT changes the encoded protein from valine (Val) to alanine (Ala). This is known as a non-synonymous mutation

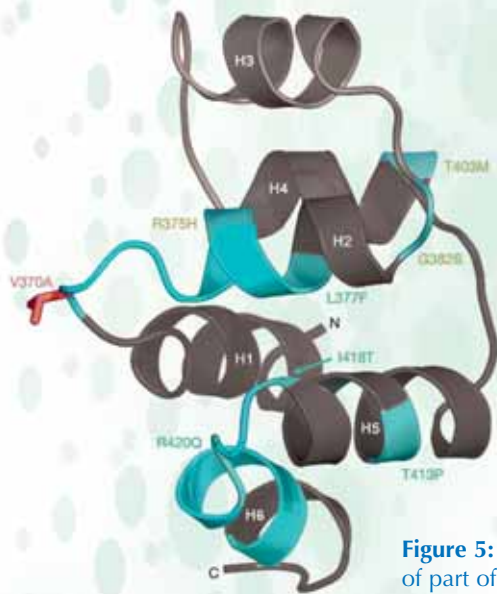

Figure 5: Hypothetical structure of part of the EDAR protein. Mutations marked in green cause ectodermal dysplasia in humans. The putatively selected SNP is marked red

ments, and we can only speculate about the selective pressures that the Asian and American populations were exposed to, which encouraged the spread of the cytosine allele. But the combination of genomic studies, laboratory experiments and animal models makes it possible to test hypotheses about the functional roles of genetic differences between populations or species. Using these approaches, we may uncover the molecular basis of past adaptations in our ancestors and other organisms, highlighting how we adapt to a constantly changing environment.

References

Bryk J (2010) Natural selection at the molecular level. *Science in School* **14**: 58-62. www.scienceinschool.org/2010/issue14/evolution

Chang SH et al. (2009) Enhanced EDAR signalling has pleiotropic effects on craniofacial and cutaneous glands. *PLoS ONE* **4(10)**: e7591. doi: 10.1371/journal.pone.0007591

This article describes the phenotype of various glands of mice with enhanced EDAR signalling, and speculates which traits could have been positively selected in human history. The article is freely available from the journal website: www.plosone.org

Chunyan M et al. (2008) Enhanced ectodysplasin-A receptor (EDAR) signaling alters multiple fiber characteristics to produce the East Asian hair form. *Human Mutation* **29(12)**: 1405-1411. doi: 10.1002/humu.20795

This article details in vitro studies of EDAR and the transgenic mice, with very nice pictures and photos.

Pongsophon P, Roadrangka V, Campbell A (2007) Counting Buttons: demonstrating the Hardy-Weinberg principle. *Science in School* **6**: 30-35. www.scienceinschool.org/2007/issue6/hardyweinberg

Sabeti PC et al. (2006) Positive natural

Adapted with permission from Macmillan Publishers Ltd: Nature, Sabeti et al. (2007), © 2007

activity (Chunyan et al., 2008; Chang et al., 2009).

Taken together, these findings suggest that the two SNP variants (containing either thymine or cytosine) may affect both the structure and function of the EDAR protein, and

may lead to physical differences in humans: differences in hair thickness and, potentially, the size of the salivary glands.

The differences in the DNA sequences that we observe now are historical records of natural experi-



Glossary

Adaptive value: a trait has an adaptive value if it enables an individual to survive and reproduce better in a given environment than individuals that do not possess this trait. More formally, a trait is regarded as adaptive if it increases fitness.

Allele: a variant of a gene.

Fitness: a hard-to-define formal term from evolutionary biology and population genetics; it describes the average number of offspring over one generation that is associated with one genotype compared to another genotype in a population. Thus genotypes that produce more offspring have greater fitness.

Genome: usually the total nuclear DNA of an organism, as opposed to including mitochondrial or plastid DNA. For further information, see 'What is a genome'

on the US National Library of Medicine website^{w2}.

Positive selection: natural selection is one of the mechanisms of evolution; it describes the different survival and reproduction of individuals in a given environment. Natural selection is called 'positive' when it promotes certain traits that help individuals to survive and reproduce better than others.

Selective pressure: a feature of the environment (e.g. temperature; presence of parasites; predation or aggression from members of the same species) that imposes differential survival and reproduction of individuals.

SNP: a single nucleotide polymorphism, or single letter in the DNA sequence that differs between individuals. Pronounced 'snip'.

selection in the human lineage.

Science **312(5780)**: 1614-20. doi: 10.1126/science.1124309

This is an excellent overview of various methods used to investigate positive selection from the genomic perspective.

Sabeti PC et al. (2007) Genome-wide detection and characterization of positive selection in human populations. *Nature* **449**: 913-918. doi: 10.1038/nature06250

Download the article free of charge from the *Science in School* website (www.scienceinschool.org/2010/issue16/evolution#resources), or subscribe to *Nature* today:

www.nature.com/subscribe

This paper describes one of the approaches to genome-wide searches for positive selection.

Xue Y et al (2009) Population differentiation as an indicator of recent positive selection in humans: an empirical evaluation. *Genetics* **183(3)**: 1065-77. doi: 10.1534/genetics.109.107722

This paper contains discussion about EDAR and other similar genes. It is freely available via PubMed Central: www.ncbi.nlm.nih.gov/pmc or using the direct link: <http://tinyurl.com/26xte2h>

Web references

w1 – The HapMap project is a partnership of scientists and funding agencies from Canada, China, Japan, Nigeria, the UK and the USA to develop a public resource that will help researchers find genes associated with human disease and the response to pharmaceuticals. See: www.hapmap.org

w2 – For more information about genomes and the Human Genome Project, see 'What is a genome' on the US National Library of Medicine website: <http://ghr.nlm.nih.gov/handbook/hgp/genome>

Resources

To browse other evolution-related articles in *Science in School*, see: www.scienceinschool.org/evolution

Jarek Bryk is a post-doctoral researcher at the Max Planck Institute for Evolutionary Biology in Plön, Germany, where he tries to find and analyse adaptive genes in mice.



Science is cool... supercool

When we cool something below its freezing point, it solidifies – at least, that's what we expect. **Tobias Schüllli** investigates why this is not always the case.

How is it possible that clouds at high altitude, at a temperature lower than 0 °C, consist of tiny droplets of water instead of ice? Actually, under certain conditions, liquids can remain liquid well below their melting point. Although this phenomenon, known as supercooling, was discovered in 1724 by Daniel Gabriel Fahrenheit (Fahrenheit, 1724), it is still the subject of much research.



- ✓ Physics
- ✓ Ages 13-18

One of nature's strange phenomena is that, for some substances, the melting point is not always the same as the freezing point. In this article, Tobias Schüllli leads us into the world of condensed matter; he introduces the differences between the states of matter, and provides an explanation of this apparent anomaly: supercooling.

The article can be used in various ways as a teaching aid. Teachers could get their students to read the article and then initiate a classroom discussion, not only about changes in states of matter but also about modern research methods in the field of condensed matter physics. To ensure that the students had understood the text, the teacher could question them, for example about conditions of crystal growth.

The article could also inspire some readers to develop their own educational material on the topic of supercooling.

Furthermore, the simple classroom activity in the article may demonstrate to students that it is not only temperature that determines the state of matter.

Vangelis Koltsakis, Greece

REVIEW

The different states of matter

For scientists, the liquid phase is a curious state of matter between order and disorder. The disordered state of matter is well illustrated by the perfect gas: the thermal movement of the individual atoms (or molecules) is so important that the attractive forces between them play no role and they move freely through space. At the other extreme, in the solid state, every atom remains at a fixed site, tightly bound to its neighbours. Driven by

the optimisation of chemical bonds and binding energies, this generally leads to the densest packing of the atoms, in a repeated three-dimensional arrangement, which is called a crystal. Therefore, what we call a solid is in fact, most of the time, a crystalline solid.

In the liquid – intermediate – state, the neighbouring atoms touch each other as in the solid state (both states are thus referred to as *condensed matter*), but the individual atoms can

migrate around, inhibiting the formation of the perfect regular pattern of a crystal. The density of a liquid (compared to a gas) thus differs very little from that of the solid state (see Figure 1).

Although a liquid is considered to be mainly disordered, atoms may arrange themselves locally in small clusters, giving rise to the notion of *local order*. The exact nature of these states of local order is very difficult to observe experimentally, but is believed to play a crucial role in the transition of a substance from a disordered phase to an ordered one.

Whether a particular substance is in the gaseous, solid or liquid phase depends on the temperature and pressure. Ice at atmospheric pressure will melt at 0 °C, mercury at -39 °C and gold at 1064 °C. As they get warmer, solids (crystals) melt at exactly these temperatures. However, the opposite is not true: when a liquid is cooled to its melting point, the formation of a crystal is possible but does not necessarily happen at exactly the melting point (Figure 2). In the striped area of the figure, a pure liquid (with no crystalline impurities) will remain liquid. We say that the liquid is supercooled. This state of matter is said to be *metastable* (Figure 3).

How can we explain supercooling?

The first explanation of supercooling lies in the physics of crystallisation. The formation of a crystal requires a nucleus of regularly arranged atoms, around which the crystal can grow. Crystallisation most commonly occurs when the liquid is in contact with a solid surface or when the liquid contains crystalline impurities; it is as if the liquid mimics the ordered structure of the neighbouring surface. This is called *heterogeneous nucleation*, starting from a *seed*.

In the absence of a crystalline solid, the spontaneous formation of a large and regular structure from the disor-

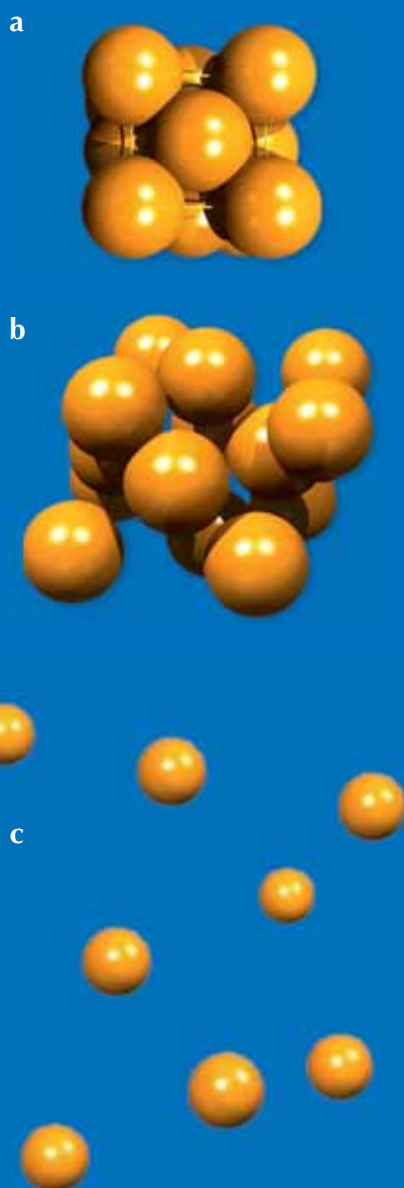

Figure 1:
The states of matter:

a) In the solid or crystalline state of matter, each atom remains at a fixed site. It can be considered to be tightly bonded to its neighbours. If we heat a crystal, the atoms begin to move (thermal vibration).

b) In the liquid state (at temperatures above the melting point), thermal movement allows the individual atoms to move around freely, although the attractive forces between the atoms ensure that they are almost as close together as in the solid state. A liquid therefore has almost the same density as a solid, and resists compression as does a solid.

c) At elevated temperatures, the thermal movement of the individual atoms in a gas becomes so important that the attractive forces between the atoms no longer play a role and the atoms can move freely through space. The density of a gas depends on the surrounding pressure and temperature. At high pressure or low temperature, the atoms may start to stick together again and condense into denser arrangements to form a liquid or a solid. For this reason, these two states are also called condensed matter

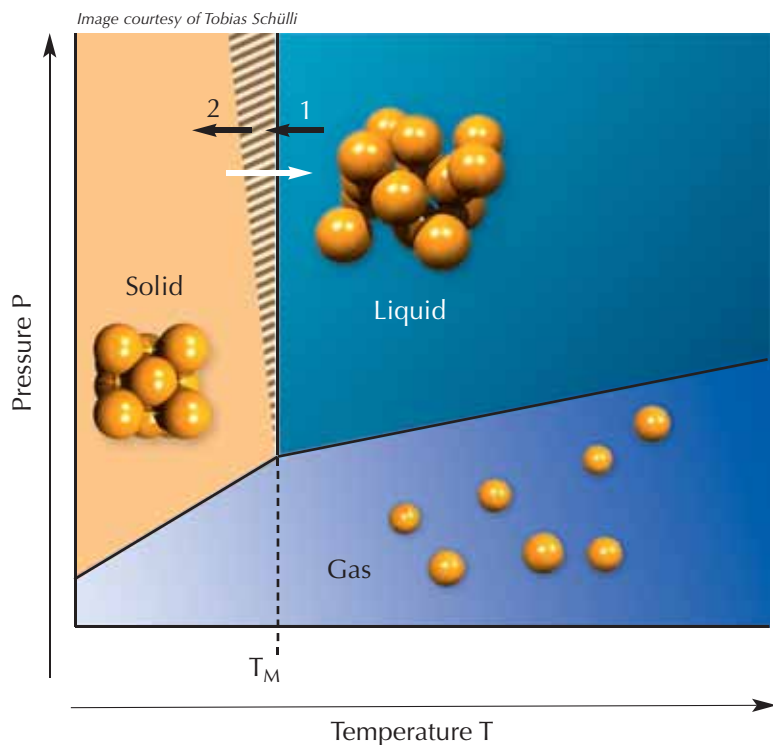

Figure 2: Phase transitions. When the temperature is raised, the solid (crystal) melts, transforming into a liquid (white arrow) at exactly the melting point, T_M . When the liquid is cooled below T_M (black arrow 1), solidification is possible but does not necessarily occur. In the striped area, a pure liquid (with no crystalline impurities) will not solidify. If the liquid is cooled further, it will solidify (black arrow 2)

dered liquid is unlikely. Although small numbers of atoms may spontaneously form a regular arrangement, these clusters are usually too small to serve as crystallisation nuclei, and quickly re-dissolve in the liquid. A pure liquid, therefore, needs to be significantly supercooled before *homogeneous nucleation* occurs: a few atoms in the liquid spontaneously order in the right manner to form a crystal that is large and stable enough to serve as the nucleus for further crystal growth (Figure 4).

Most of the tiny droplets of water which constitute stratiform and cumulus clouds do not contain any seed crystals; these droplets can remain liquid well below 0 °C.

Deep supercooling in metals

Even more spectacular than water, which can be supercooled only about

40 degrees below its melting point of 0 °C, are metals, which can exist as liquids at several hundred degrees below their melting point. This is known as *deep supercooling* and has challenged scientists to go beyond the crystal nucleation theory to explain the metastability of liquids (Turnbull, 1952).

Scientists have speculated that the internal structure of some liquids could be incompatible with crystallisation. In the 1950s, Frederick Charles Frank suggested that the densest arrangement of a small number of atoms may be different to the local arrangement of atoms in a crystal, and that these clusters in a liquid are therefore ordered in the wrong way to serve as a crystallisation nucleus (Frank, 1952).

As a model, Frank used the icosahedron: a central atom with twelve sur-

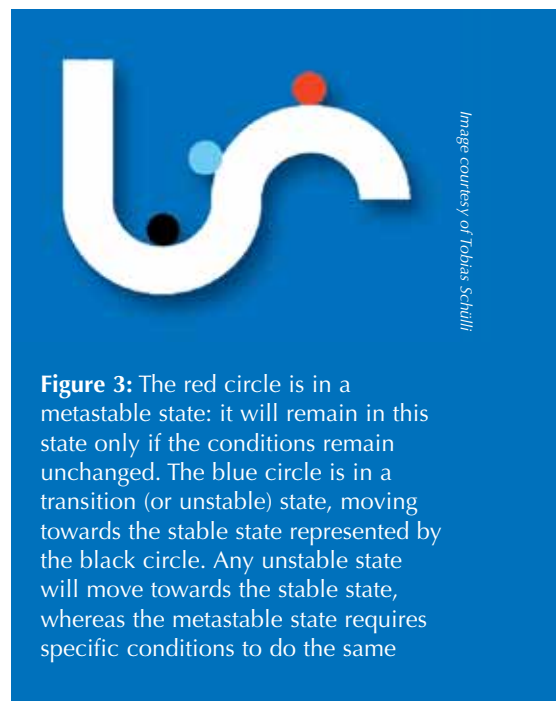

Figure 3: The red circle is in a metastable state: it will remain in this state only if the conditions remain unchanged. The blue circle is in a transition (or unstable) state, moving towards the stable state represented by the black circle. Any unstable state will move towards the stable state, whereas the metastable state requires specific conditions to do the same

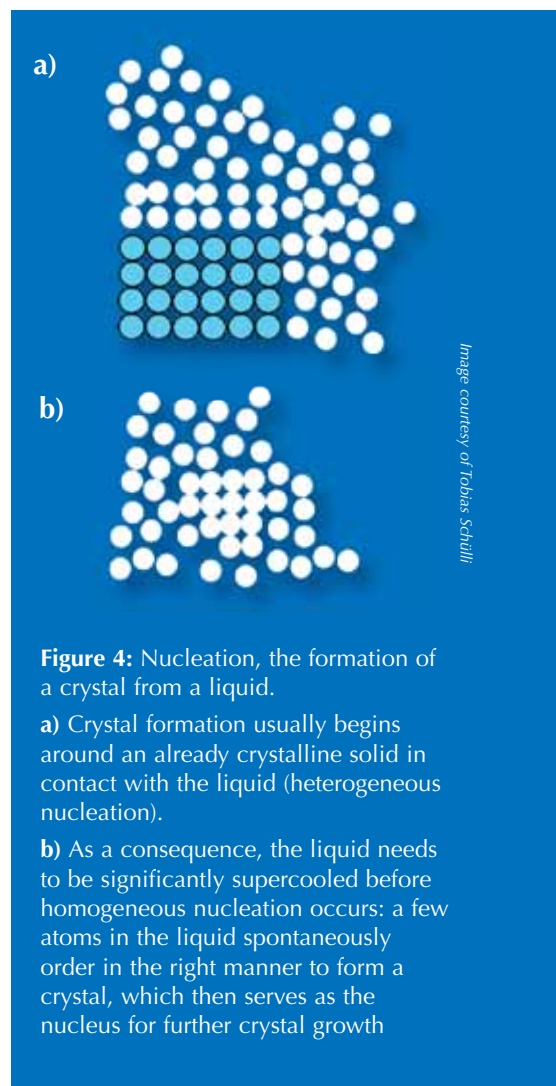

Figure 4: Nucleation, the formation of a crystal from a liquid.

a) Crystal formation usually begins around an already crystalline solid in contact with the liquid (heterogeneous nucleation).

b) As a consequence, the liquid needs to be significantly supercooled before homogeneous nucleation occurs: a few atoms in the liquid spontaneously order in the right manner to form a crystal, which then serves as the nucleus for further crystal growth

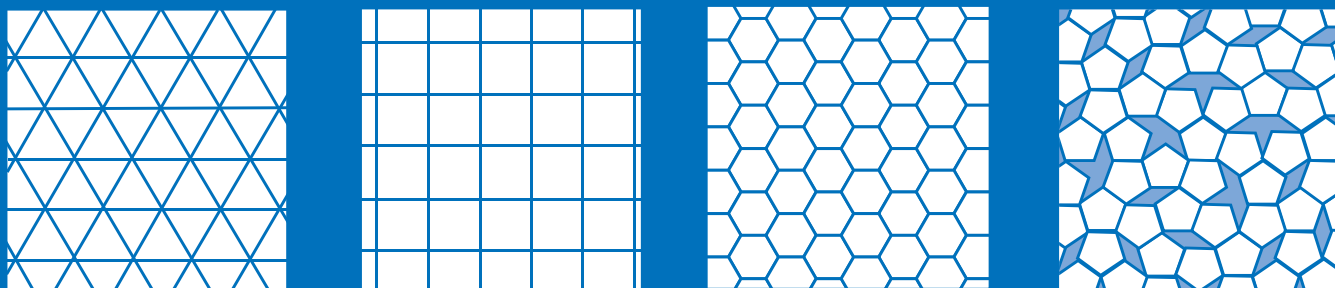

Figure 5: Triangles (three-fold symmetry), squares (four-fold symmetry) and hexagons (six-fold symmetry) can fill a plane perfectly, whereas pentagons (five-fold symmetry) cannot

rounding atoms. Such a structure, which has a pentagonal symmetry, cannot form the basis of a crystal. Generally, a crystalline structure has to repeat in three dimensions, like bricks in a wall. A cubic arrangement, for example, is an excellent structure for a crystal, as it is both dense and perfectly regular.

Using a two-dimensional comparison, triangles, rectangles or hexagons

can fill a plane perfectly, whereas pentagons cannot (Figure 5). In three dimensions, pentagonal structures are incompatible with the formation of a crystal (Figure 6).

Recent simulations and theoretical models support Frank's idea, suggesting that a significant fraction of the atoms in liquids arrange themselves in clusters with five-fold symmetry, thus presenting an obstacle to crys-

tallisation. So far, however, very few experiments have allowed the visualisation of pentagonal symmetry in liquids (Reichert et al., 2000).

Supercooling in semiconductor nanostructures

My own encounter with the phenomenon of supercooling was not really intentional. Actually, the focus of my research, within a team at the



CLASSROOM ACTIVITY

Experiment with supercooling

Place an unopened bottle of still mineral water in the freezer for 1–2 hours. After this time, the water should be around -10 to -5 °C. Because the water should have no solid impurities in it, it should still be liquid even at this temperature – it is supercooled.

Carefully remove the bottle from the freezer, then hit it on the table or with your hand. You should be able to see that the water crystallises (freezes), with the ice formation progressing very quickly through the whole bottle. The crystallisation is triggered by the shock wave travelling through the liquid. (The shock wave is another possible explanation of why aeroplanes leave a visible trail of water crystals behind them.)

This can only be achieved in liquids that do not contain seeds that may provoke crystallisation. It is

unlikely to work with tap water, which may contain crystalline impurities that trigger crystallisation closer to the melting (freezing) point of water.

Note: do not leave the bottle in the freezer for too long, because once the water gets below -10 to -5 °C, it will freeze, even if there are no crystalline impurities.



Images courtesy of Tobias Schüllli

Images courtesy of Tobias Schüll

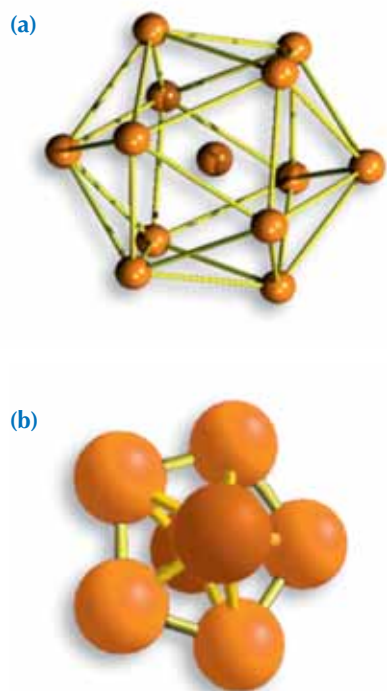

Figure 6: Two examples of structures that are not compatible with the formation of a crystal:

- (a) An icosahedron, the densest arrangement possible for 13 atoms.
- (b) A cluster of 7 atoms with pentagonal symmetry

CEA^{w1} in Grenoble, France, was to understand and improve novel growth methods for semiconductor nanostructures. In these methods, the processes of solidification and nucleation are crucial. The attention of our team was attracted by a report on supercooling in droplets of metal–semiconductor alloys: these droplets offered us a good system to study the influence of a crystalline seed (a silicon surface) on the solidification of the alloy.

We deposited tiny droplets (0.1-0.2 μm) of a liquid gold–silicon alloy on a silicon surface, prepared under ultra-high vacuum conditions, a standard technique used in semiconductor processing. We observed that, while in contact with this crystalline surface, the droplets remained liquid at 240 °C, well below their melting point (which is 363 °C). To understand this extraordinary supercooling behaviour (usually only observed in the absence of crystalline seeds), we carried out

an experiment at the European Synchrotron Radiation Facility (ESRF)^{w2}, also in Grenoble. The scattering of very intense X-rays produced in a synchrotron is a unique way to obtain information about the arrangement of atoms in a liquid and on solid surfaces.

We fired X-rays almost parallel to the surface of the silicon crystal on which the droplets of gold–silicon alloy had been deposited. At an angle of only 0.1° (a technique called *grazing*

Figure 7: Droplets of liquid gold-silicon alloy all melted at the same temperature. As they cooled, however, the differences in the crystalline silicon surfaces on which the droplets sat affected the temperature at which the droplets crystallised.

(a) When the silicon crystal was cut along the cubic facets, the silicon atoms at the surface that was in contact with the droplet were arranged in a square lattice. On this surface, the droplets crystallised at about 60 K below their melting point. X-ray results showed that the droplet had crystallised in a structure and orientation similar to the silicon crystal on which it sat.

(b) When the silicon crystal was cut in the spatial diagonal of the cube, the silicon atoms at the surface that was in contact with the droplet were arranged in a triangular lattice. The droplet on this surface crystallised at about 70 K below its melting point. X-ray results showed that the droplet too had crystallised in a structure and orientation similar to the silicon crystal on which it sat.

(c) The silicon crystal was cut as in (b) but underwent a special treatment at high temperature that provoked the formation of a pentagonal atomic arrangement of gold atoms bonded to the silicon surface. On this surface, the droplets remained in their metastable liquid phase down to 120 K below the melting point – deeply supercooled

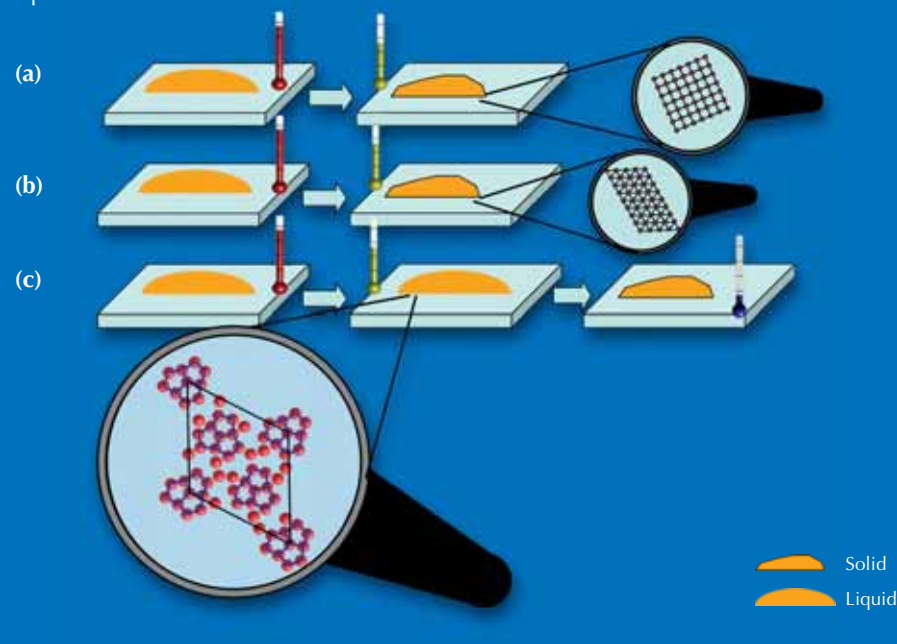

Image courtesy of Tobias Schüll

incidence), the X-rays are reflected by the flat silicon surface and penetrate the droplets deposited on it. The scattered X-rays carry information about the atomic arrangement of the last atomic layer of the silicon surface, as well as about the structure of the droplets.

These experiments allowed us to determine the state (liquid or crystalline) of the droplets as they were cooled, and to determine the exact atomic arrangement of the upper atomic layer of the silicon surface. The X-ray results showed that in the uppermost atomic layer of the silicon surface, the atoms were arranged with five-fold symmetry. On these surfaces, even when cooled to more than 100 degrees below their melting point, the droplets remained liquid.

A more detailed analysis of the solid / liquid interface revealed that these pentagonal surface structures were formed from a single layer of gold atoms bonded tightly to the silicon crystal. As explained before, we generally expect liquids to mimic the solid structure with which they are in contact, provoking heterogeneous nucleation. Our measurements showed that such mimicry of the surface structure takes place, but that it can have the opposite effect: a structure that is incompatible with the formation of a 3D crystal can force the liquid to locally adopt the 'wrong' type of order. Instead of triggering heterogeneous nucleation, this increases the stability of the supercooled phase of the liquid (see Figure 7).

After 60 years of research into supercooling of metals, this is finally the experimental demonstration that five-fold symmetry affects the metastability of a liquid (Schüllli et al., 2010; Greer, 2010).

References

- Fahrenheit DG (1724) Experimenta & observationes de congelatione aquæ in vacuo factæ. *Philosophical Transactions* **33**: 78-84. doi: 10.1098/rstl.1724.0016
- Frank FC (1952) Supercooling of liquids. *Proceedings of the Royal Society* **215**: 43-46. doi: 10.1098/rspa.1952.0194
- Greer AL (2010) Materials science: a cloak of liquidity. *Nature* **464**: 1137-1138. doi: 10.1038/4641137a
Download the article free of charge on the *Science in School* website (www.scienceinschool.org/supercooling#resources), or subscribe to *Nature* today: www.nature.com/subscribe.
- Reichert H et al. (2000) Observation of five-fold local symmetry in liquid lead. *Nature* **408**: 839-841. doi: 10.1038/35048537
Download the article free of charge on the *Science in School* website (www.scienceinschool.org/supercooling#resources), or subscribe to *Nature* today: www.nature.com/subscribe.
- Schüllli TU et al. (2010) Substrate enhanced supercooling in AuSi eutectic droplets. *Nature* **464**: 1174-1177. doi: 10.1038/nature08986
Download the article free of charge on the *Science in School* website (www.scienceinschool.org/supercooling#resources), or subscribe to *Nature* today: www.nature.com/subscribe.
- Turnbull D (1952) Kinetics of solidification of supercooled liquid mercury droplets. *Journal of Chemical Physics* **20**: 411-424. doi: 10.1063/1.1700435

Web references

- w1 – The CEA is the French Atomic Energy and Alternative Energies Commission (*Commissariat à l'énergie atomique et aux énergies alternatives*). To learn more, see: www.cea.fr
- w2 – The European Synchrotron Radiation Facility (ESRF) is an international research institute for cutting-edge science with photons. ESRF is a member of EIROforum, the publisher of *Science in School*. To learn more, visit: www.esrf.eu

Resources

- For a further consideration of clouds, see:
- Ranero Celius K (2010) Clouds: puzzling pieces of climate. *Science in School* **17**: x-y.
www.scienceinschool.org/2010/issue17/clouds
- To see all other *Science in School* articles about ESRF, see www.scienceinschool.org/esrf

Tobias Schüllli studied physics and mathematics at the University of Stuttgart, Germany. He obtained his PhD at the Johannes Kepler University Linz, Austria, for the development of X-ray scattering methods in the study of semiconductor nanostructures. In 2003 he joined the *Commissariat à l'énergie atomique et aux énergies alternatives* (CEA) Grenoble, where he studied crystal surfaces and nanostructure growth in situ using synchrotron radiation at the ESRF. In 2009, he moved to ESRF and is in charge of the upgrade of one of its instruments, dedicated to the study of nanostructures and interfaces using highly focused X-ray beams.

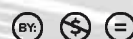

Going ballistic: modelling the trajectories of projectiles

Students often find it difficult to calculate the trajectories of projectiles. With the help of **Elias Kalogirou's** model, they can be easily visualised. In addition, **Ian Francis** suggests further uses for the model in the classroom.



- ✓ Physics
- ✓ Maths
- ✓ Arts / design and technology
- ✓ Ages: 15+

The idea behind the model-building experiment proposed in this article is very creative, and the students will learn through active participation, using many skills along the way. Once constructed, the model will also serve as a visual aid for theory covered in class; this is complemented by suggestions for a set of activities that can be performed during the lesson.

Depending on their students' abilities, teachers may choose to leave the discovery of the theories behind the experiments to their students, or guide them on their way.

The activity would definitely fit into the physics curriculum, as part of teaching motion (projectiles), a topic included in most European curricula. The activity can be considered as interdisciplinary, since the construction of the model involves the students' design and technology skills. There is also, of course, the mathematical component of the activity.

Jürgen Azzopardi, Malta



Images courtesy of yemwen / iStockphoto

Images courtesy of Elias Kalogirou

The projectile trajectory model

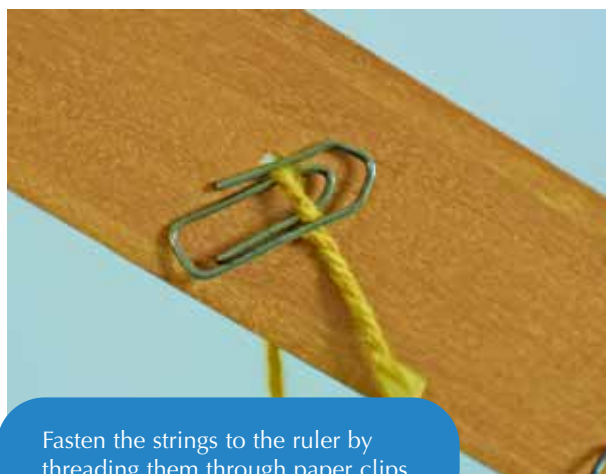
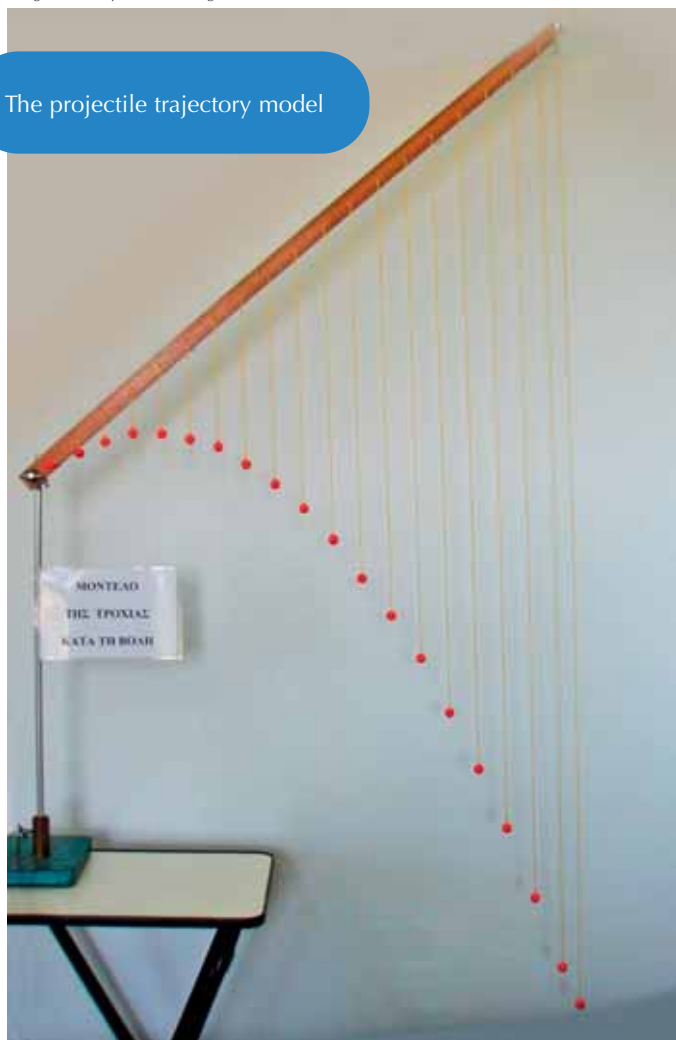

Fasten the strings to the ruler by threading them through paper clips

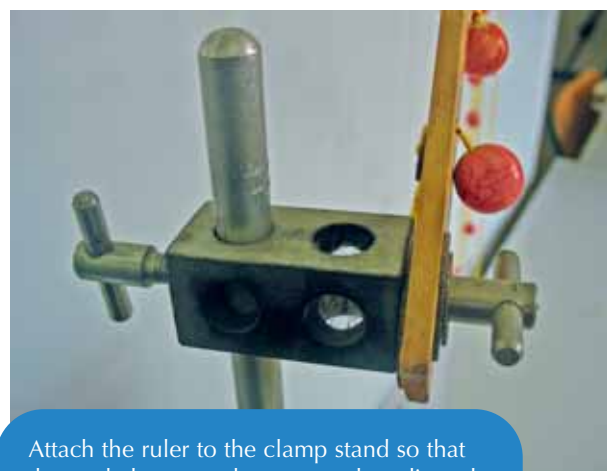

Attach the ruler to the clamp stand so that the angle between the two can be adjusted

Building the model

By Elias Kalogirou

Introduction

When you throw or hit a ball, shoot a bullet from a gun or drop a stone from a bridge, the 'flying' objects all have one thing in common: in the physical sense, they are *projectiles*. This term is used for any object that is given an initial velocity and subsequently follows a distinct trajectory: a path determined by a combination of gravity and air resistance. I have devised a model to help visualise these trajectories in the classroom and allows students to investigate horizontal and vertical components of projectile motion. Note that air resistance is not included in the model.

Construction

Materials

- A clamp stand
- A wooden ruler, at least 105 cm long
- A drill and drill bits
- Thin string, preferably coloured
- 20 wooden or plastic beads, 14 mm in diameter, with a hole through which the string can be threaded
- 20 paper clips
- A tape measure
- A pair of scissors

Procedure

1. At a small distance from one end of the ruler (I used 3 cm), drill a hole through the ruler, with which

to fasten it to the clamp stand.

2. Drill 20 holes (I used a diameter of 2.5 mm) at intervals of 5 cm in the ruler, the first one 5 cm from the hole drilled in step 1.
3. Attach the ruler to the clamp stand. The angle between the two needs to be adjustable, so fasten the ruler on a pivot – I used a clamping boss and two rings to do so (see image).
4. For each of the 20 holes, calculate the corresponding length of string required (see Table 1). Allow about 5 cm extra – for attaching the string to the bead and the ruler – and cut the strings.
5. For each string, tie a bead to one end, pass the other end through the corresponding hole in the ruler,

and attach it by threading the string through a paperclip that will act as a stopper (see image). Do not use sticky tape instead of the paper clips, as this will gradually work itself loose.

6. Adjust the strings to exactly the calculated length.

The model is now complete. As a guide, it took me about two hours to build.

Calculating the lengths of string

To understand how we calculate the lengths of the strings, we need to understand what the model represents. Imagine that at time zero, you fired a bullet at steady speed (no horizontal acceleration) from the pivot point (connecting the ruler and the clamp stand), in the direction that the ruler is pointing in.

The model demonstrates two aspects of a trajectory. Firstly, the direction in which the ruler is pointing gives the direction in which the bullet would continue flying if there were no gravity.

Secondly, the strings represent the effect of gravity (g). If you let the bullet drop from the pivot point at time zero (vertical fall without initial velocity), the length of string of the first bead would give the distance the bullet would have fallen after time t , the string of the second bead would give the distance the bullet would have fallen after $2t$, and so on (see Table 1).

Gravity has the same effect on a projectile with an initial velocity greater than zero, so when you shoot the bullet rather than letting it drop, it would still fall the same distance by time t .

For an initial velocity greater than zero, the length of the first string again gives the distance the bullet would have fallen after time t , the second string gives the distance the bullet would have fallen after $2t$, and so on. The beads, therefore, represent the parabolic trajectory of a projectile, with the angle of the ruler to the

Time	Distance along the ruler (cm)	Distance fallen	String length	String length if $a = 0.3652$ (cm)
t	5	$\frac{1}{2} g t^2$	a	0.3652
$2t$	$2 \times 5=10$	$\frac{1}{2} g (2t)^2$	$4a$	1.4608
$3t$	$3 \times 5=15$	$\frac{1}{2} g (3t)^2$	$9a$	3.2868
$4t$	$4 \times 5=20$	$\frac{1}{2} g (4t)^2$	$16a$	5.8432
...
$20t$	$20 \times 5=100$	$\frac{1}{2} g (20t)^2$	$400a$	145

Table 1: Vertical fall using the model

stand representing the starting angle of the projectile.

The positions of the 20 beads, hanging 5 cm apart, give you the positions of the bullet at 20 equidistant consecutive time points – the first bead at time t , the second bead (5 cm further along the ruler) at $2t$, and so on, up to the last bead, at $20t$.

The model represents trajectories at constant horizontal velocity (including zero, if you place the ruler in a vertical position, parallel to the stand) and constant vertical acceleration. Once you have chosen your value for t , cut the strings and built the model, it will be a model for trajectories with this specific value of t , i.e. also for a specific velocity and acceleration (gravity) – at different angles, depending on how you position the ruler, and disregarding air resistance. How closely the model reflects reality could be an interesting point for discussion with your students.

The length of the shortest string, at time t , is calculated as:

$$a = \frac{1}{2} g t^2.$$

To calculate its length (a), choose the maximum length of string for bead number 20, which is 100 cm from the pivot point, and corresponds to $400a$ (see Table 1). Our longest string ($400a$) was 145 cm, so $a = 0.3652$. Then you can calculate the lengths of string you need to cut for the 20 different beads using the 'String length' column in Table 1 (and do not forget the 5 cm extra when cutting, see step 4 on page 24).

Using the model in class

By Ian Francis

The actual construction of the model is already a valid act of learning in itself. In addition, the finished product can be used for further work. It can be used to study either horizontal or vertical trajectories, as well as those at any angle in between. Below are some suggestions – there will be plenty of others.

Experiment 1

In this experiment, students should learn that the horizontal and vertical components of a trajectory are independent of each other, with the horizontal velocity remaining constant during the 'flight'.

1. Ask the students to position the ruler so that it is held horizontally (at 90 degrees to the clamp stand). The beads now indicate the positions of a projectile that has an initial horizontal velocity but no initial vertical velocity (like a coin flicked horizontally off a table top).
2. Ask the students to estimate how long it would take for a projectile to move from the starting position (the pivot) to the first bead (or indeed from any bead to the next). Any time that is less than one second will be fine.

Next, we will try to get this number closer to a true figure – which will of course vary depending on how quickly the projectile is launched.

3. Get the students to flick a coin alongside the model, trying to get

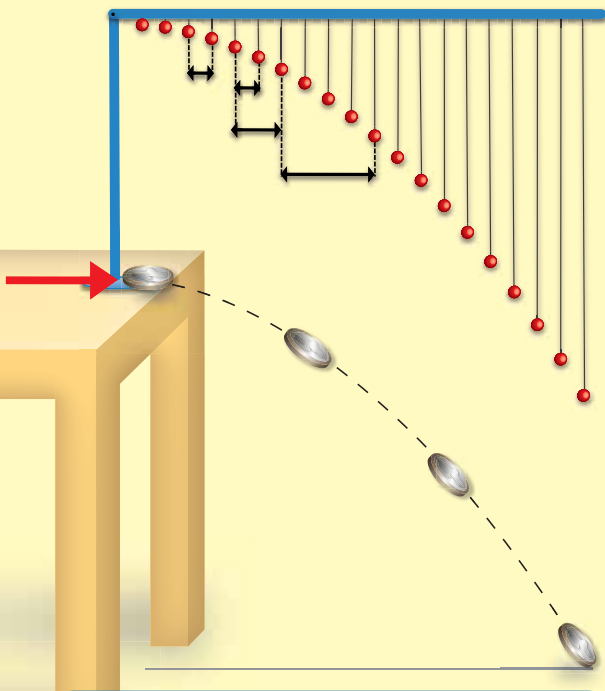

The set-up for Experiment 1. Students should measure the horizontal distance between consecutive and non-consecutive bead pairs and time the travel of a coin flicked alongside the model

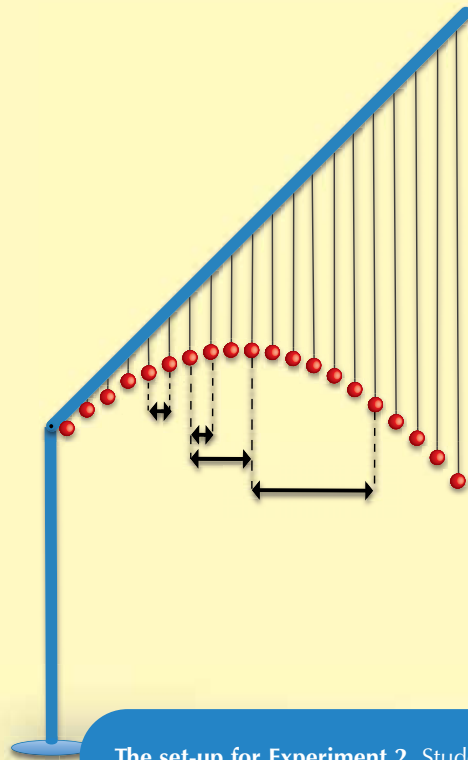

The set-up for Experiment 2. Students should measure the horizontal distance between consecutive and non-consecutive bead / string pairs – this will be smaller than in Experiment 1

the coin to travel a horizontal distance similar to the length of the ruler, and time how long it takes before the coin lands. Dividing that time by the number of beads the coin has passed will give an approximate interval for the flight time between successive beads, ignoring air resistance. The longer the trajectory, the less significant any timing error should be.

4. With this figure for the time interval, ask the students to calculate the horizontal velocity for a few pairs of beads (both consecutive ones and pairs of beads that are further apart, e.g. between bead 3 and 4, then between beads 3 and 15 – make sure the students remember to use the appropriate time interval if using non-consecutive beads in the pair), using horizontal velocity = horizontal displacement / time interval: $v_{\text{horiz}} = h_{\text{horiz}} / t$.

Make sure that the students measure the horizontal distance between bead pairs, not the diagonal distance. If the model has been built accurately, they should find that the horizontal velocity is constant.

Students may be familiar with the average velocity formula, but less so with the idea of dividing up a motion into small time intervals. Therefore, it could be worth having them calculate the average horizontal velocity = total horizontal displacement / total time. This should, of course, equal the velocities worked out from adjacent bead positions.

5. Ask the students which assumption we are making when we assume that the horizontal velocity of a projectile is constant. The answer should be that air resistance can be ignored.

Experiment 2

In this experiment, students learn that the horizontal velocity will still be constant for a trajectory with initial vertical velocity (i.e. at an angle away from the horizontal), but it will be smaller than that for a trajectory with no initial vertical velocity (as in Experiment 1).

1. Position the ruler of the model at an angle away from the horizontal. I would suggest using a fairly steep angle so that students come up with a noticeably different horizontal displacement to that in the first experiment.
2. Using the value for t that you have calculated in Experiment 1 – or the value for t used to build the model – ask the students to repeat the calculation of the horizontal velocity, as in step 4 of Experiment 1. Again, if the model has been built

accurately, the students should find that the horizontal distance travelled in equal intervals of time is constant, but it will of course be smaller than that for a trajectory with no initial vertical velocity (Experiment 1) – the strings of adjacent beads will be closer to one another.

Experiment 3

In this experiment, the students study the vertical distances travelled in equal intervals of time for a trajectory with no initial vertical velocity (such as in Experiment 1). The experiment is best suited to students who were not involved in building the model, although it can be useful reinforcement for those students, too.

1. Return the ruler to a horizontal setting.

A change in the vertical velocity is an acceleration (a), and from the equation $F = ma$ we know that a resultant force is needed to produce such an acceleration – in this case the force of gravity acting on the object. As this force is constant, from equations of uniformly accelerated motion, we get

vertical distance travelled

$$(s) = (u t) + (\frac{1}{2} a t^2)$$

where u = initial velocity.

As the initial vertical velocity (u) is zero, $(u t)$ can be ignored, and as $\frac{1}{2} a$ is a constant, the relationship tells us that vertical distance travelled is proportional to time squared. It may be worth pointing out that acceleration (a) and gravity (g) are interchangeable in this context, both representing the acceleration of freefall.

2. Ask students to calculate the elapsed time for each bead position (note that at the pivot, $t = 0$) – this will be $1t$ for bead 1, $2t$ for bead 2, etc. (see Table 1), using the value for t built into the model.
3. Let the students measure the lengths of strings at different positions – if time is too short to meas-

ure all 20, get them to measure at least the shortest and the longest strings, and 3 strings in between – and note down the values. This is the vertical distance fallen at each point.

4. Get the students to plot vertical distance travelled against elapsed time squared (i.e. t^2 for point 1, $(2t)^2$ for point 2, etc.) for each of the positions measured including point zero.

Instead of using the value for t built into the model, students could use the value calculated in Experiment 1. If this does not correspond to the value of the model, the graph will still be the expected straight line, showing the same correlation, but only above the second point in the graph.

Experiment 4

This simple experiment serves to reinforce the fact that the vertical and horizontal components of a velocity are independent of each other.

1. Place the ruler at a 45 degree angle to the stand.
2. Students should satisfy themselves that the vertical displacements are of course unchanged, i.e. the distance from any particular bead to the ruler will always be the same, irrespective of the angle at which the ruler is held, as the lengths of the strings have not altered.

Further ideas

These are further questions you can ask the students to investigate:

- What angle to the horizontal will give the greatest horizontal displacement on level ground? What if the ground is not level?
- How could the model be adapted to account for planets where the acceleration due to gravity is smaller or greater than the 9.8 m/s^2 on Earth?
- Can the students determine instantaneous vertical velocities by taking pairs of readings from the rulers held at an angle? Can they use these velocities to see how

close the model shows an acceleration due to gravity of 9.8 m/s^2 ?

- Does the determination of vertical acceleration change with the angle at which the ruler is held?

Resources

Freier GD, Anderson FG (1981) *Demonstration Handbook for Physics* (2nd edition). College Park, MD, USA: American Association of Physics Teachers. ISBN: 9780917853326

To view an animated demonstration of the projectile motion, see: www.phy.hk/wiki/englishhtm/ThrowABall.htm

Wikipedia has a good explanation of the trajectory of a projectile, especially the section 'Angle θ required to hit coordinate (x,y) ': http://en.wikipedia.org/wiki/Trajectory_of_a_projectile

If you enjoyed reading this article, why not take a look at the list of physics articles published in *Science in School* so far? See: www.scienceinschool.org/physics

Elias Kalogirou has been a physics teacher for 10 years and really enjoys teaching his students things they can apply in everyday life. He is responsible for operating the regional laboratory centre of physical sciences in Pyrgos, Iliia, Greece, at which secondary-school science teachers can improve their teaching by learning experimental methods for the physics, chemistry and biology classrooms.

Ian Francis has taught secondary-school science and advanced-level physics for around 20 years, mostly in London, UK, and southeast England. He is also an examiner for national examinations (GCSE and A levels) and has authored teaching materials for various UK projects including 'I'm a scientist, get me out of here!' and SEPnet (South East Physics Network).



Bioinformatics with pen and paper: building a phylogenetic tree

Bioinformatics is usually done with a powerful computer. With help from **Cleopatra Kozlowski**, however, you can investigate our primate ancestry – armed with nothing but a pen and paper.

As a result of recent technological advances, it is relatively quick and easy to determine a DNA or protein sequence. These sequences by themselves, of course, tell us very little: GAATCCA, for example. We need to know what those sequences mean. Which proteins are encoded by that DNA sequence; does the sequence indeed encode a protein at all? What effect does a small change in the DNA sequence have on the structure of the encoded protein? What function does that protein have in the cell? And, of course, what can our DNA sequence tell us about our evolutionary history?

These and other important biological questions can be tackled with bioinformatics: essentially, by com-



REVIEW

When we think of bioinformatics we probably imagine huge computers and sequencing machines, but the methods of this new science can be presented by means of simple classroom activities to be carried out with pencil and paper, as Cleopatra Kozlowski does in this article.

The author challenges us with the building of the family tree of humans and other primates on the basis of the genetic differences between short (fake) DNA sequences. The proposed activity can be profitably (and enjoyably) exploited in secondary schools to address some tricky biology topics such as the use of molecular clocks in the study of evolution.

The article is aimed at science teachers, who will find useful comprehension exercises at the end of the text; students can also use the questions to deepen their understanding of the topic. The quoted web references provide further information and resources.

Giulia Realdon, Italy

paring DNA or protein sequences – for example, by comparing newly discovered sequences with sequences for which we already have a lot of information (perhaps they have a similar function?) or comparing similar sequences in different species.

Bioinformatics is, of course, normally done with the aid of a powerful computer. However, it is all too easy to let a computer do all the work without understanding the underlying principles involved. For this reason, these activities are designed to be done on paper, to get the students to understand *how* bioinformatic analysis works.

This article includes one of a group of four activities. The two introductory activities ('Gene finding' and 'Mutations') and the concluding activity ('Mobile DNA') can be downloaded from the website of the European Learning Laboratory for the Life Sciences (ELLS)^{w1}. All the tables

required for students to complete this activity, together with the step-by-step procedure and answers to the comprehension questions, can be downloaded from the *Science in School* website^{w2}.

Constructing a phylogenetic tree

The accumulation of mutations causes DNA sequences to change over generations. The following activity demonstrates how this can be used to deduce evolutionary relationships between organisms. It takes about 90 min and requires nothing but a pen and the tables, which can be downloaded from the *Science in School* website^{w2}.

Introduction

Think about how you would classify diverse animals. Traditionally, physical differences between organisms were used to deduce evolutionary relationships between them, for

example, whether an organism has a backbone, or if it has wings. This may cause problems, however. For example, birds, bats and insects all have wings, but are they closely related? How do you measure how recently the organisms diverged from a common ancestor?

We know from DNA sequencing studies that DNA mutations occur randomly at a very slow rate and are passed from parents to offspring. Thus, if you assume that all organisms have a common ancestor, you can use the differences in *homologous sequences* to measure how long it has been since the organisms diverged. In other words, the longer the time since two species diverged from a common ancestor, the more different their DNA sequences will be.

Homologous sequences are defined as those sequences in two organisms that have a common origin. In reality we don't really have proof that any

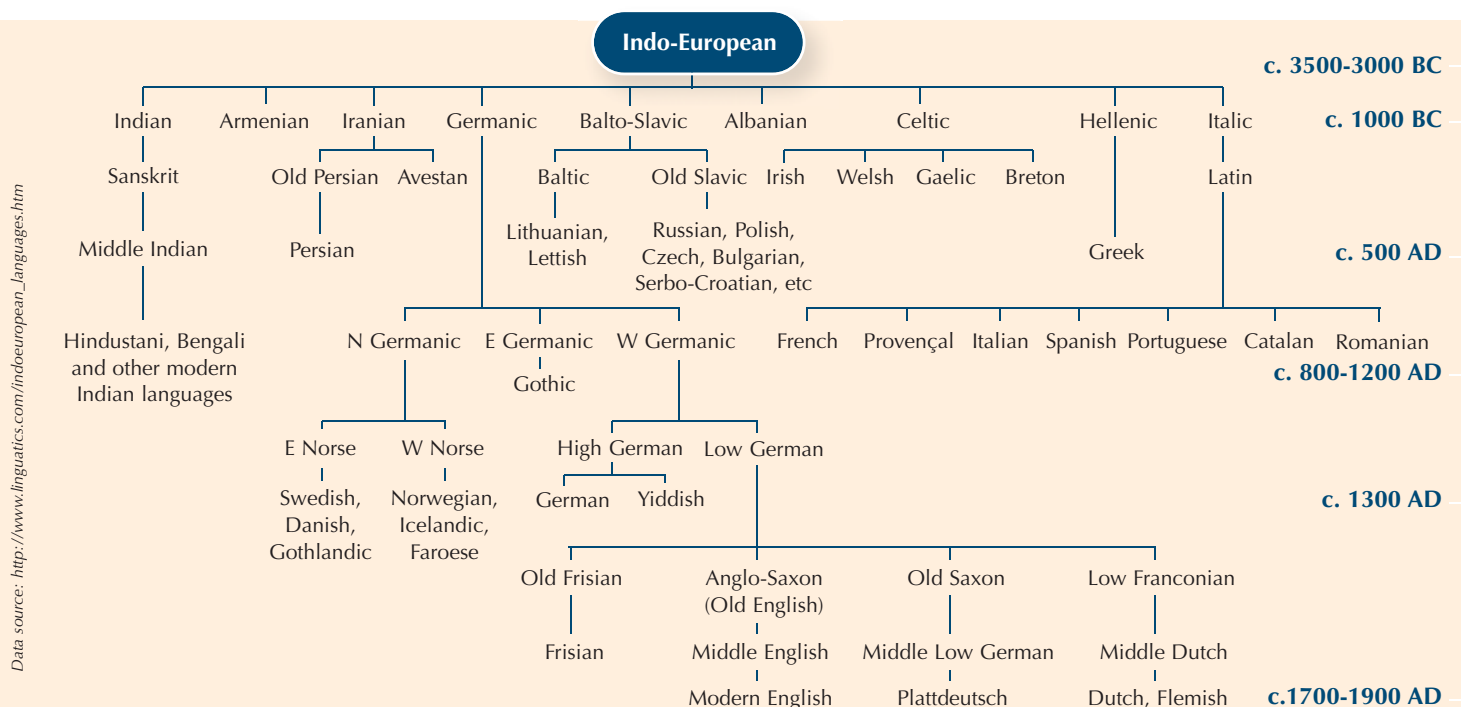

Figure 1: The Indo-European language tree. Note that although Indian, Germanic, Romance and many other European languages belong to this family, Finnish, Estonian and Hungarian do not: they belong to the Uralic language group

two sequences are homologous (we were not there to watch the DNA changing over time) but if they are sufficiently similar, we often assume that they are ‘homologues’. To know how similar two sequences are, you need to *align* them correctly (but this is not part of this activity).

Note that different regions of the DNA – coding and non-coding regions – evolve at different speeds. In general, coding regions evolve more slowly, because a mutation that causes a change in a protein is generally more costly to the organism – it is less likely to survive and leave off-

spring. This is discussed in the ‘Mobile DNA’ activity.

To illustrate the concept of homology, you can use the example of philology – the study of the evolution of languages. In fact, there are many parallels between the methods used to study evolution of language and organisms.

Using the differences between fragments of DNA sequences is a bit like comparing a word that means the same thing in different languages, to see how closely they are related.

Table 1: List of ‘cat’ in Indo-European languages

Armenian	gatz
Basque	catua
Dutch	kat
English	cat
Estonian	kass
Finnish	kissa
Icelandic	kottur
Italian	gatto
Norwegian	katt
Polish	kot
Portuguese	gato
Russian	kot
Spanish	gato
Swedish	katt

You can see that the words for ‘cat’ in Italian, Spanish and Portuguese are almost the same: gatto, gato and gato. In both Swedish and Norwegian, the word is ‘katt’ but you see that in Finnish it is different: ‘kissa’. Although, like Sweden and Norway, Finland is a Nordic country, the Finnish word for ‘cat’ is more similar to the Estonian word, ‘kass’. In fact, the two languages are closely related. So you can learn a little bit about language relationships by studying how the words have changed over time.

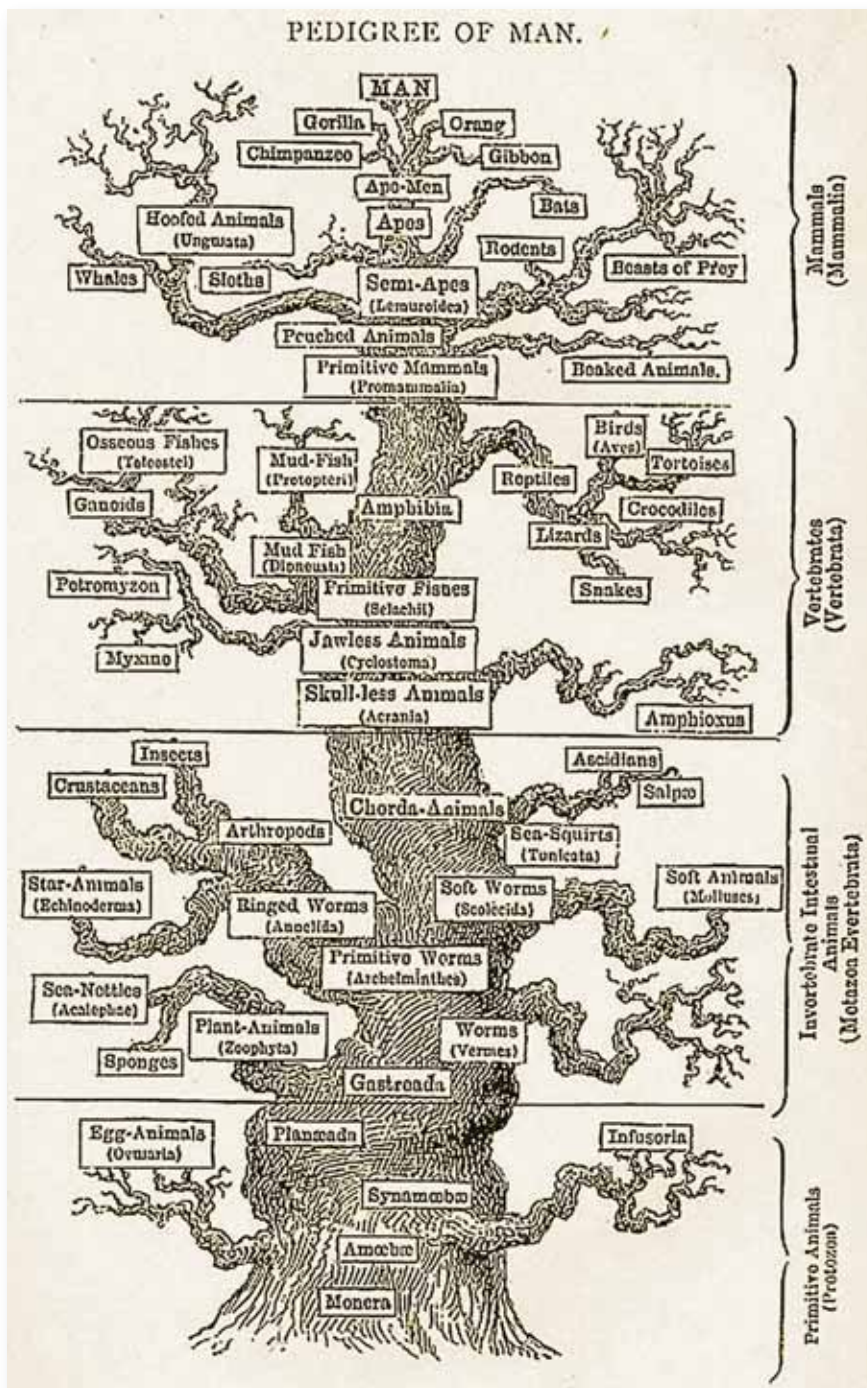

Haeckel's tree of life from *The Evolution of Man* (1879)

Constructing a phylogenetic tree of primates

In this activity, we will construct a phylogenetic tree using five homologous DNA sequences from primates. Because the sequences have been made up, we cannot deduce any real estimates of genetic distance; to create a meaningful phylogenetic tree from real data would require far longer sequences. Nonetheless, the fictional sequences (in Table 2) have been chosen to give a reasonably accurate picture of primate relationships.

Note: all the tables required for students to complete this activity can be downloaded from the *Science in School* website^{w2}.

1. Count the number of differences between each pair of sequences, and record it in Table 4. This is easy to do if you compare each sequence side by side. For example, Neanderthals and humans differ at three nucleotides in the sequence (Table 3a) whereas chimpanzees and gorillas differ at 11 points (Table 3b).

Comparison tables for all the pairs of species, and the completed table of sequence differences (Table 4), can be downloaded from the *Science in School* website^{w2}.

The number of nucleotide differences between two sequences divided by the total number of nucleotides in each sequence (in this case, 46) gives the proportional distance between the two sequences.

2. Consider the two species with the most similar sequences: Neanderthal and human. In Table 5, record the number of nucleotide differences (3) and the proportional difference ($3/46 = 0.065$).

The 'average sequence' of two species is assumed to be their ancestor. In this exercise, we do not directly calculate the average sequence of, for example, Neanderthals and humans, but the evolutionary distance between the Neanderthal/human ancestor, and all other primates in the group.

Table 2: Five DNA sequences from primates

Primate	Sequence
Neanderthal (n)	TGGTCCTGCAGTCTCTCCTGGCGCCCCGGGCGCGAGCGGTTGTCC
Human (h)	TGGTCCTGCTGTCTCTCCTGGCGCCCTGGGCGCGAGCGGATGTCC
Chimpanzee (c)	TGATCCTGCAGTCTCTTCTGGCGCCCTGGGCGCGTGCGGTTGTCC
Gorilla (g)	TGGACCTGCAGTCATCTTCTGCCCGCCCCGAGCGCTTGCCGATGTCC
Orangutan (o)	ACAACCTGCACTCTATTCTGCCGAGCCGGGCGCGTGGCAAAGTCC

Table 3a: A comparison of Neanderthal and human sequences

Neanderthal	TGGTCCTGCAGTCTCTCCTGGCGCCCCGGGCGCGAGCGGTTGTCC
Human	TGGTCCTGCTGTCTCTCCTGGCGCCCTGGGCGCGAGCGGATGTCC

Table 3b: A comparison of chimpanzee and gorilla sequences

Chimpanzee	TGATCCTGCAGTCTCTTCTGGCGCCCTGGGCGCGTGCGGTTGTCC
Gorilla	TGGACCTGCAGTCATCTTCTGCCCGCCCCGAGCGCTTGCCGATGTCC

Table 4: Sequence differences between primates

	Neanderthal	Human	Chimpanzee	Gorilla	Orangutan
Neanderthal	0	3			
Human	3	0			
Chimpanzee			0	11	
Gorilla			11	0	
Orangutan					0

Table 5: Evolutionary distances between primate ancestors and primates

	Differences	Proportional difference
Neanderthal and human	3	$3/46 = 0.065$
Neanderthal / human and chimpanzee		
Neanderthal / human / chimpanzee and gorilla		
Neanderthal / human / chimpanzee / gorilla and orangutan		

Table 6a: Sequence differences between the Neanderthal/human ancestor and other primates

	Neanderthal / human	Chimpanzee	Gorilla	Orangutan
Neanderthal / human	0	$(4+5)/2 = 4.5$	$(11+12)/2=11.5$	
Chimpanzee	$(4+5)/2 = 4.5$	0		
Gorilla	$(11+12)/2=11.5$		0	
Orangutan				0

3. Calculate the distance between the average sequence of the Neanderthals and humans, and the other primate species and enter the data in Table 6a.

There are four differences between Neanderthal, and chimpanzee and five differences between human and chimpanzee. Thus the average distance between Neanderthal/human and chimpanzee is 4.5.

There are 11 differences between Neanderthal and gorilla, and 12 differences between human and gorilla. Thus the average distance between Neanderthal/human and gorilla is 11.5.

4. As before, these distances can be turned into proportional differences by dividing by the number of nucleotides in each sequence (46). Calculate the proportional distances between the average sequence of the Neanderthals / humans, and the other primate species. Enter the figures in Table 5. For chimpanzees, the proportional distance from the Neanderthal / human ancestor is $4.5/46 = 0.98$.

Using Table 5, you can begin to construct the evolutionary tree.

5. Connect Neanderthals and humans with a line. The branch length should correspond to how long it took for humans and Neanderthals to diverge from their common ancestor.

Let us assume that it would take 20 million years for every single nucleotide in this particular DNA sequence to change. Thus for the DNA sequence to change by 0.065, it would take $0.065 \times 20 \text{ million} = 1.3 \text{ million years}$. The branch should, therefore, measure 1.3 million years on the time scale (see Figure 2).

6. To calculate how long ago the ancestor of chimpanzees diverged from the ancestor of humans (the branch length), add up the proportional differences in Table 5. Remember that the proportional

Image courtesy of Nicola Graf

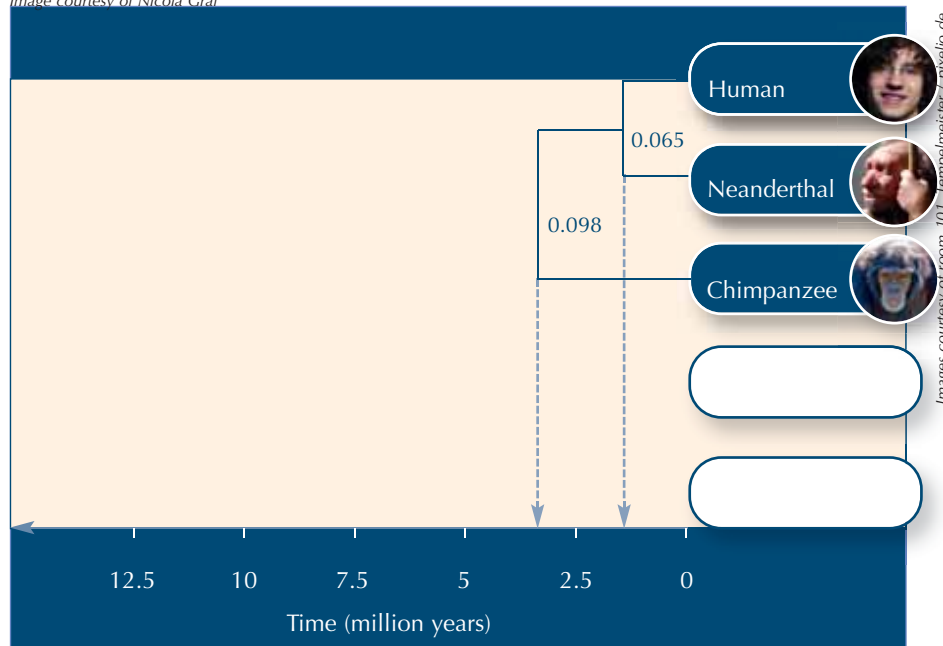

Images courtesy of room 101, Tempelmeister / pixelio.de

Figure 2: Incomplete phylogenetic tree

distance between the Neanderthal / human ancestor and the chimpanzee was 0.98. Thus the time since chimpanzees, humans and Neanderthals diverged from a common ancestor is:
 $(0.065 + 0.098) \times 20 \text{ million}$
 $= 0.163 \times 20 \text{ million}$
 $= 3.3 \text{ million years ago}$.

7. Continue the calculations. Repeat steps 3 to 6 to calculate how long ago the Neanderthal / human / chimpanzee ancestor diverged from the gorilla and from the orangutan. Then calculate how long ago the Neanderthal / human / chimpanzee / gorilla ancestor diverged from the orangutan. Enter the results in Table 5.

If you need help, you can download the step-by-step procedure from the *Science in School* website.

8. Use the completed Table 5 to finish the phylogenetic tree, as shown on page 33.

Questions

Below are some questions you could use to test your students' understanding of the activity. Answers can be downloaded from the *Science in School* website^{w2}.

1. In your phylogenetic tree, how many years ago did gorillas and humans diverge from a common ancestor? What about orangutans and humans?
2. Can you find out if these and the other estimates in your tree are correct?
3. Why may phylogenetic trees constructed using different regions of the DNA look different?
4. What regions of DNA should you use to compare organisms that are closely related?
5. What kind of genes should you use to compare organisms that are evolutionarily distant from each other?
6. What should you do if you are comparing two sequences, but one of them has gaps due to deletions (or insertions in the other sequence)?
7. Can you think of reasons why this method of simply comparing the number of differences between the nucleotides may not work if you are comparing organisms that are very different? Remember that we are assuming it takes 20 million years for every nucleotide in a sequence to mutate.

Image courtesy of Nicola Graf

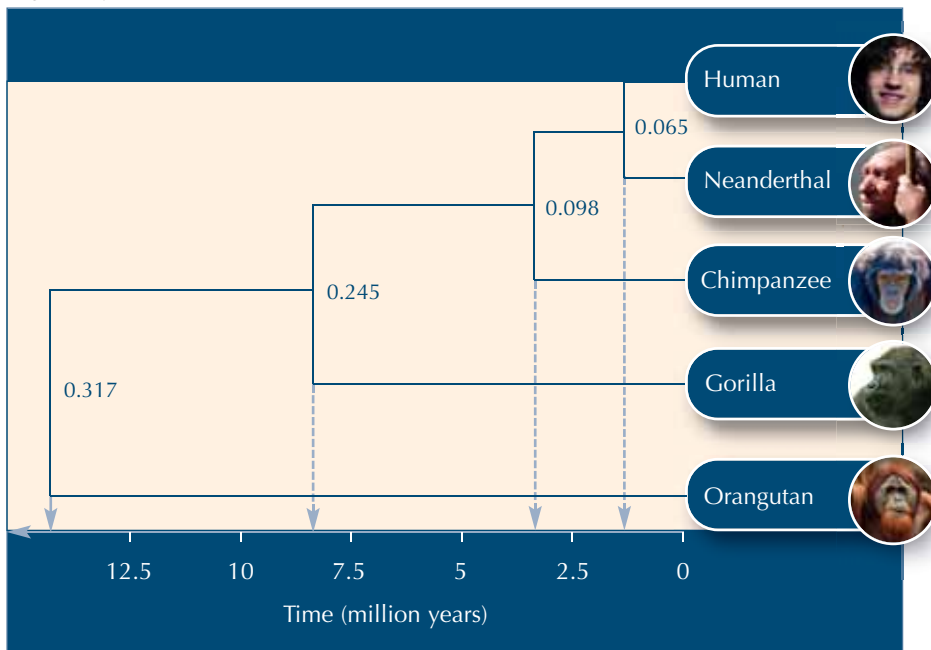

Figure 3: Complete phylogenetic tree

8. Can you think of other reasons why it may not be so good to use this method to calculate evolutionary distances? What simplifications have we made?
9. Can you think of reasons why if you are studying more distant organisms, it is better to compare amino acid sequences than DNA sequences?
10. In this exercise, we have concentrated on working out *when* the five primate species diverged from each other (the scale of the tree). Often, however, we do not even know *the order* in which the species diverged from one another (the shape of the tree). How do we know, for example, that humans and chimpanzees are more closely related than gorillas and chimpanzees are? If the latter were true, how would the sequence differences (Table 4) differ?

Acknowledgement

This activity was developed in a special collaboration between the European Learning Laboratory for the Life Sciences (ELLS)^{w1} and the European Molecular Biology

Laboratory's E-STAR Fellows to develop teaching resources for schools. Cleopatra Kozłowski was supported by an E-STAR fellowship funded by the European Commission's Framework Programme 6 Marie Curie Host Fellowship for Early Stage Research Training, under contract number MEST-CT-2004-504640.

Web references

w1 – The European Learning Laboratory for the Life Sciences (ELLS) is an education facility which brings secondary-school teachers into the research lab for a unique hands-on encounter with state-of-the-art molecular biology techniques. ELLS also gives scientists a chance to work with teachers, helping to bridge the widening gap between research and schools. The activity described in this article was designed as a teaching resource for ELLS' professional development programme for European teachers. For more information about ELLS, see: www.embl.org/ells

w2 – Download all the tables required for students to complete this activity, together with the step-by-step procedure and answers to the comprehension questions, from the *Science in School* website: www.scienceinschool.org/2010/issue17/bioinformatics#resources

Resources

The website of the US National Center for Biotechnology Information (NCBI) offers an introduction to phylogenetics. See: www.ncbi.nlm.nih.gov/About/primer/phylo.html

To learn more about using protein sequences to establish phylogenetic trees, see: <http://users.rcn.com/jkimball.ma.ultranet/BiologyPages> or use the direct link: <http://tinyurl.com/2wqp7nq>

To learn about how a group of scientists recreated the new tree of life, tracing the course of evolution, see: Hodge R (2006) A new tree of life. *Science in School* 2: 17-19. www.scienceinschool.org/2006/issue2/tree

The Interactive Tree Of Life is an online tool for the display and manipulation of phylogenetic trees. To learn more, see: <http://itol.embl.de>

To browse other evolution-related articles in *Science in School*, see: www.scienceinschool.org/evolution

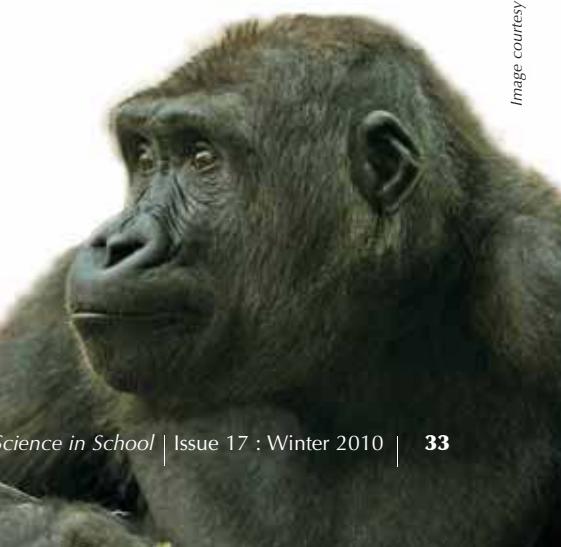

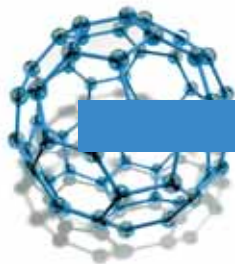

School experiments at the nanoscale

Eleanor Hayes highlights some education resources about the nanoscale and nanotechnology.

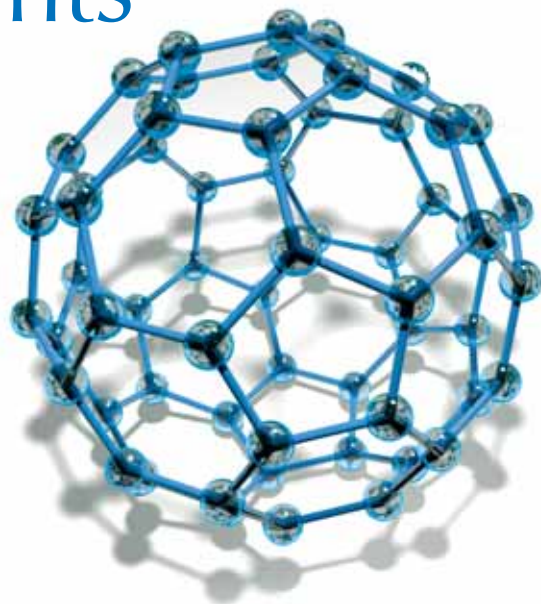

Image courtesy of maggi07 / iStockphoto

With the help of many education projects, introducing the nanoscale at school has never been easier – whatever the age of your students. Below are two experiments (for children aged 8+ and for 14- to 16-year-olds); many more resources are listed at the end of the article.

Dilution and the sense of smell

In the following experiment, suitable for ages 8 and above, food colouring is serially diluted, causing the colour and smell to fade gradually. The colour will fade more quickly than the smell, illustrating that even though our eyes cannot detect the chemical responsible for the colour, it is still present, as verified by the smell.

In the same way as we use our eyes to see large things and our nose to smell small things, nanoscientists use special tools to analyse (and manipulate) things at the very small scale: the nanoscale. Atomic force microscopes can feel and move individual atoms, while special surfaces with nanotextures on them can repel water extremely efficiently.

The experiment is taken from the 'Time for nano' project, which offers informal education materials about

Image courtesy of the Deutsches Museum



the benefits and risks of nanoscale research, engineering and technology. The website and materials are available in nine languages (Dutch, English, Finnish, French, German, Italian, Polish, Portuguese and Turkish). The project members – science centres across Europe – also offer 'nanodays', with demonstrations, experiments, games, meetings and discussions about nanotechnology. For more information, see the Time for Nano website^{w1}.

Introduction

When introducing the activity, the following examples may help to illustrate how small the nanoscale is.

- Our nails grow 1 nm each second.
- The virus most usually responsible for the common cold has a diameter of 30 nm.
- A cell membrane is around 9 nm across.
- The DNA double helix is 2 nm across.
- The diameter of one hydrogen atom is around 0.2 nm.

Encourage students to consider the things that they cannot see directly, for example the ozone layer, dyes in stained glass windows or the colloidal nature of milk.

Explain that the olfactory bulb of the brain is responsible for interpreting the smells that the nose detects. The olfactory bulb is strongly linked to a part of the brain that is responsible for remembering things, which is why certain smells can make us remember specific things clearly.

The students can calculate that in each tube, the food colouring is ten times more dilute than the previous tube. By the time they reach Tube 9, the original food colouring has been diluted to the level of one part of food colouring to a billion parts of water.

Image courtesy of the Deutsches Museum

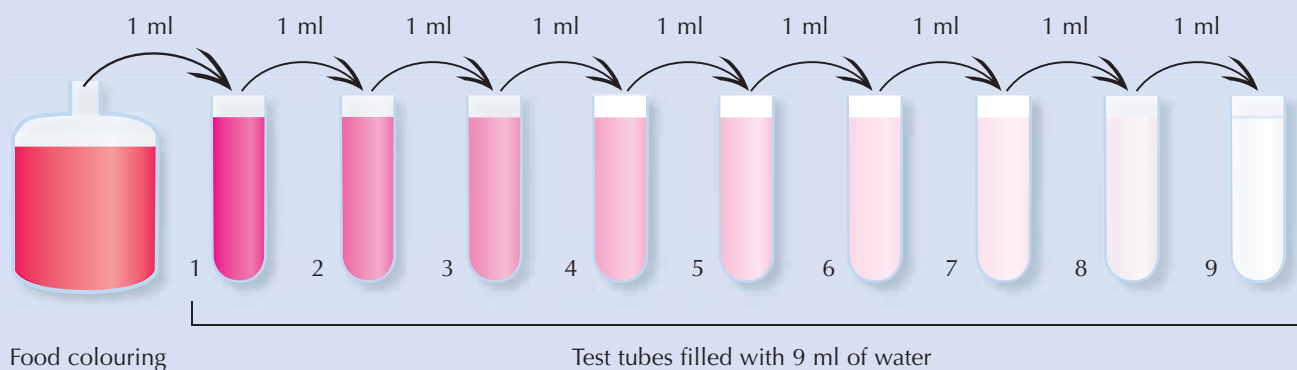

Materials

- Some scented (this is important) food colouring
- A Pasteur pipette
- Nine test tubes, numbered 1-9.

Procedure

1. Carefully fill each test tube with 9 ml of water.
2. Using the Pasteur pipette, carefully add 1 ml of food colouring to Tube 1. Mix the tube thoroughly.
3. Smell the contents. What does it smell of? Does it smell the same as the original food colouring?
4. Now take 1 ml of liquid from Tube 1, add it to Tube 2 and mix thoroughly.

5. Continue the process by repeating steps 3 and 4: dilute Tube 2 into Tube 3, Tube 3 into Tube 4, and so on.

At what point can you no longer see any colour in the tubes?

At what point can you no longer smell anything in the tubes?

How can you explain the difference?

The method you have just used is called a serial dilution. If you wanted, in just one step, to dilute 1 ml of the food dye to the same concentration as in Tube 9, how much water would you need?

Image courtesy of the Deutsches Museum



Safety notes

- Do not eat the food colouring.
- Some people might be intolerant of the food dye. If it comes into contact with skin, wash it off with lots of water.
- Avoid getting the food colouring on clothes, as it will stain.

Building a liquid crystal thermometer

Liquid crystals have properties between those of a conventional liquid and those of a solid crystal; for example, a liquid crystal may flow like a liquid, but its molecules may be oriented in a particular direction, as in a crystal. Liquid crystals are sensitive to external factors, such as temperature, and change their molecular arrangement when these factors vary. In response to a change in temperature, some types of liquid crystal (thermotropic ones) change colour as a result of a change in assembly.

In this experiment, students investigate colour changes in a thermotropic liquid crystal and then build their own liquid crystal thermometer. The protocol, which is suitable for students aged 14-18, was developed as part of the 'Nanoyou' project. Extensive supporting materials are available (in Danish, English,

German, Italian, Portuguese and Slovak) from the project website^{w2}.

The Nanoyou website is available in 12 languages and offers a range of free materials, including posters, presentations, card games, role plays and a teachers' training kit. This kit covers the fundamental concepts in nanoscience and nanotechnologies; applications of nanotechnologies; four laboratory experiments and a virtual experiment. Separate kits are available for the 11-13 and 14-18 age groups.

Schools that participate in the project work directly with leading European nanoscience research centres, receiving nanotech-related materials and taking part in workshops. Particular focus is given to ethical, safety and social implications, as well as present and future limits to scientific development. To learn how to get involved, visit the Nanoyou website^{w2}.

Preparation

For this experiment, you will need four different mixtures prepared from three liquid crystals:

- Cholesteryl oleyl carbonate (CAS number 17110-51-9, Sigma-Aldrich 151157; 25 g costs about €60)
- Cholesteryl pelargonate (CAS number 1182-66-7, Sigma-Aldrich C78801; 100 g costs about €115)
- Cholesteryl benzoate (CAS number 604-32-0, Sigma-Aldrich C75802; 25g costs about €40)

The instructions for preparing each of these liquid crystal mixtures ('Student synthesis procedure') and supporting material for teachers are available to download from the Nanoyou website^{w2}.



Images courtesy of sethela / iStockphoto

Materials

- 4 pre-prepared liquid crystal mixtures
- 4 10-ml vials
- A sheet of sticky-back plastic (used e.g. for covering books)
- A spatula
- Scissors
- A permanent marker pen
- A room thermometer
- An A4 sheet of white paper
- An A4 sheet of black paper
- A water bath (or a hotplate, a Pyrex glass water container half filled with water, and thermometer)
- A clothes peg
- An A4 sheet of foam
- An A4 sheet of black card
- Gloves
- Safety glasses
- Paper tissue
- Sticky tape (optional)
- A hairdryer (optional)

Safety notes

Solids should not be inhaled. Wear gloves and safety glasses; contact with skin, eyes or clothing should be avoided. Wash your hands thoroughly after handling the liquid crystals.

Procedure

Preparing the liquid crystal sheets

1. Using Table 1, prepare four different liquid crystal mixtures, each of which is sensitive to different ranges of temperatures.

Table 1: Preparing the liquid crystal mixtures

Liquid crystal mixture	Sensitivity temperature (°C)	Cholesteryl oleyl carbonate	Cholesteryl pelargonate	Cholesteryl benzoate
Mixture 1	17–23	0.65	0.25	0.10
Mixture 2	26.5–30.5	0.45	0.45	0.10
Mixture 3	32–35	0.40	0.50	0.10
Mixture 4	37–40	0.30	0.60	0.10

2. Cut two pieces of sticky-back plastic (about 10 x 10 cm), peel off the backing paper and lay the plastic (sticky side up) on the bench.
3. Place 2-3 spatulas of the liquid crystal mixture 1 in the centre of one of the sheets. If the liquid crystal has solidified, warm the vial first with a hairdryer until the mixture has the consistency of honey.

4. Place the second piece of sticky-back plastic on top of the first piece, sticky side down. As you do this, gently press the middle to distribute the liquid crystal evenly, creating a thin layer of liquid crystal about 4 x 4 cm. Do not press too hard, otherwise the mixture will leak out; if it does, clean it up immediately with paper tissue.
5. Cut off any excess plastic and label the corner of the sheet with the number of the liquid crystal mixture (1).
6. Repeat the same procedure for liquid crystal mixtures 2-4.

Image courtesy of the 'Nanoyou' project

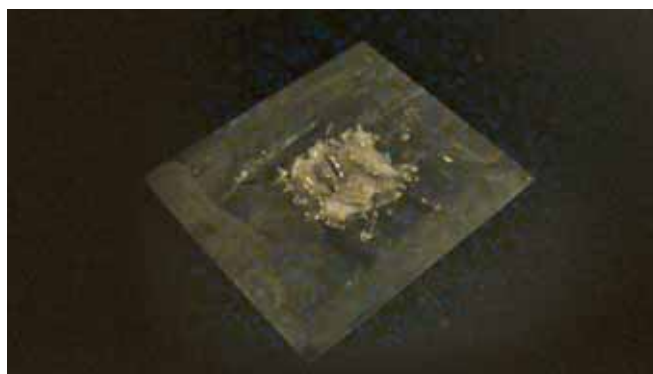

The finished liquid crystal sheet

Use the room thermometer to determine the temperature in the room you are in.

Could any of your liquid crystal mixtures be used to determine the room temperature? If so, which one?

Investigating the temperature changes

1. Place your four liquid crystal sheets on a sheet of white paper. Wait few seconds. What do you see?
2. Wearing gloves, press your finger against each of the liquid crystal sheets. (To make a fair comparison, you need to keep your finger on each liquid crystal sheet for the same length of time.) What do you see now?
3. Repeat the procedure on a sheet of black paper.
4. Record your observations in Table 2. (Tables 2-6 can be downloaded from the *Science in School* website^{w3}.)

Images courtesy of the 'Nanoyou' project

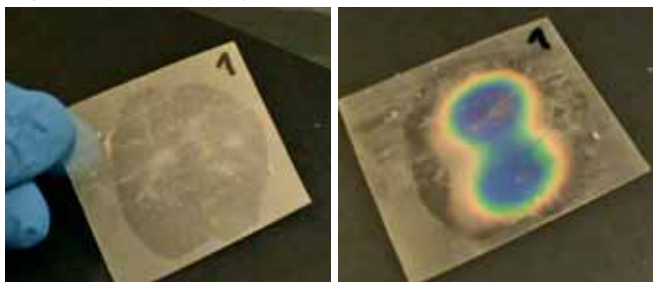

The liquid crystal sheet before and after it has been touched

Table 2: Testing the four liquid crystal sheets

	White paper	Black paper
Sheet 1 (mixture 1)		
Sheet 2 (mixture 2)		
Sheet 3 (mixture 3)		
Sheet 4 (mixture 4)		

Why do you get different results when you test the liquid crystal sheets against white paper and black paper?

Did all four liquid crystal sheets display some colour? If not, why not? What could you do to make these sheets display colour?

- Rub your hands together and test each of the sheets again. Do you see any difference?

Testing the liquid crystal sheets

- Fill the water bath with cold water and raise the temperature to 15 °C.
- Keep a thermometer in the water to check the temperature.
- Place a sheet of black paper behind the water bath, to make any colours visible. **Note:** the paper should not touch the hotplate.
- Holding it with a clothes peg, immerse liquid crystal sheet 1 in the water bath (see image below). Can you see any colour?
- Raise the water temperature to 23 °C. In Table 3, record the colours that you see as the temperature increases.

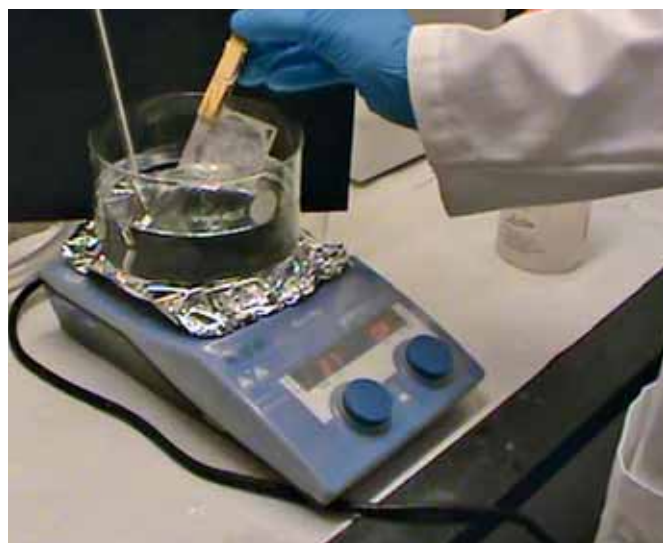

Image courtesy of the 'Nanoyou' project

Immersing the liquid crystal sheet in the water bath

Table 3: Temperature-dependent colour changes of mixture 1

Liquid crystal sheet number 1		
Temperature (°C)	Colour	Comments
16		
17		
18		
19		
20		
21		
22		
23		

At what temperature do you start to see some colour in sheet 1? Does this correspond to the temperature predicted in Table 1?

Does the order of colours that you have recorded in the table above follow a particular pattern? If so, what pattern and why do you think this might be?

- Take the liquid crystal sheet out of the water bath.

Does it lose its colour immediately? If not, why not?

Imagine putting sheet 1 in a water bath of unknown temperature. If the sheet turned orange what temperature would the water be?

- Place liquid crystal sheet 2 in the water bath (now at 23 °C) and raise the temperature to 30 °C. Record your observations in Table 4.

Table 4: Temperature-dependent colour changes of mixture 2

Liquid crystal sheet number 2		
Temperature (°C)	Colour	Comments
22-23		
23-24		
25		
26		
27		
28		
29		
30		

- When the water temperature reaches 30 °C, test sheet 1 again. Can sheet 1 detect temperatures around 30 °C? Why/why not?

- Place liquid crystal sheet 3 in the water bath (now at 30 °C) and raise the temperature to 35 °C. Record your observations in Table 5.

Table 5: Temperature-dependent colour changes of mixture 3

Liquid crystal sheet number 3		
Temperature (°C)	Colour	Comments
30		
31		
32		
33		
34		
35		

- Place liquid crystal sheet 4 in the water bath (now at 35 °C) and raise the temperature to 40 °C. Record your observations in Table 6.

Table 6: Temperature-dependent colour changes of mixture 4

Liquid crystal sheet number 4		
Temperature (°C)	Colour	Comments
35		
36		
37		
38		
39		
40		

Was the colour sequence that you observed for sheets 2-4 the same as for sheet 1? Why/Why not?

When you take sheets 2, 3 and 4 out of the water bath, do they behave like sheet 1? If not, what is the difference? Why?

Which of the four liquid crystal mixtures would you use to see whether you have a raised temperature? Why?

Constructing the liquid crystal room thermometer

- On the sheet of white foam, use the permanent marker pen to write the word 'NANO'. You will need to cover each letter with one of the four liquid crystal sheets, so make sure the single letters are large enough but not too large (see image right).

- Cut the four letters out of the foam, leaving a single sheet of foam with holes spelling the word 'nano'.
- Turn the sheet of foam over and cover each letter with one liquid crystal sheet, as follows:
N – sheet 1
A – sheet 2
N – sheet 3
O – sheet 4
- Using sticky-back plastic or sticky tape, fasten the liquid crystal sheets to the foam, making sure that each letter only exposes one sheet.
- Cover the liquid crystal sheets with the sheet of black card, fastening it to the white foam. Your room thermometer is now complete.

Does your room thermometer show any colour? If not, why not?

If your thermometer does not show any colour, try placing it over a working laptop computer. It will demonstrate what we all know – that they heat up.

Image courtesy of the 'Nanoyou' project



The finished thermometer

Your thermometer will last 3-6 months, after which it can be disposed of as normal waste.

How is this nano?

The properties of materials at the macroscale are affected by the structure of the material at the nanoscale. Changes in a material's molecular structures are often too small to see directly with our eyes, but sometimes we can see changes in the material's properties. Liquid crystals are an excellent example, in particular the type used in this experiment, since their optical properties (colour) change visibly as the temperature of the liquid crystal is changed. In nanotechnology, scientists take advantage of the peculiar properties of materials at the nanoscale to engineer new materials and devices.

Acknowledgements

Time for Nano is funded by the European Commission under the 7th Framework Programme.

The liquid crystal experiment published on the Nanoyou website was adapted from the 'Preparation of cholesteryl ester liquid crystals' – one of the many experiments listed on the website of the University of Wisconsin-Madison, USA^{w4} – and from the 'Exploring materials: liquid crystals' activity developed by the Nanoscale Informal Science Education network^{w5}.

The 'Nanoyou' (Nano for Youth) project is funded by the European Commission under the 7th Framework Programme (FP7/2007-2013) under grant agreement 233433.

Web references

w1 – To learn more about the Time for Nano project, enter the video competition, download experimental protocols or find out about forthcoming events, see: www.timefornano.eu

w2 – Supporting materials for the liquid crystal experiment, including details of how to synthesise the liquid crystals, are available from the Nanoyou project website (www.nanoyou.eu) or via the direct link: <http://tinyurl.com/2ulmsta>

w3 – All the tables needed for recording the results of the experiment can be downloaded from the *Science in School* website: www.scienceinschool.org/2010/issue17/nano#resources

w4 – For the instructions for preparing cholesteryl ester liquid crystals, see the website of the University of Wisconsin-Madison's Materials Research Science and Engineering Center (<http://mrsec.wisc.edu>) or use the direct link: <http://tinyurl.com/34kq8qn>

w5 – For the 'Exploring materials: liquid crystals' activity, see the website of the Nanoscale Informal

Science Education network (<http://www.nisenet.org>) or use the direct link: <http://tinyurl.com/35el37p>

Resources

For some nanotechnology experiments published in a previous issue of *Science in School*, see:

Mallmann M (2008) Nanotechnology in school. *Science in School* 10: 70-75. www.scienceinschool.org/2008/issue10/nanotechnology

The Nano and Me website includes a discussion of what we mean by 'nano' in food. See: www.nanoandme.org/nano-products/food-and-drink

To learn more about our sense of smell, see the Nanooze website: www.nanooze.org/english/articles/5senses_noseknows.html

For a video of serial dilution, see the website 'Dr Shawn's Science Fair Success Series': <http://web.mac.com/drshawn1>

The Nano mission website offers downloadable educational games that introduce basic concepts in nanoscience through real-world practical applications, from microelectronics to drug delivery. See: www.nanomission.org

The Wellcome Trust's free *Big Picture* series for teachers and students (aged 16 and above) explores issues around biology and medicine. It can be downloaded or ordered online.

In June 2005, the *Big Picture* focused on nanotechnology. See: <http://www.wellcome.ac.uk> or use the direct link: <http://tinyurl.com/344mpws>

The Discover Nano website from the Northwestern University, Chicago, USA, offers an interactive timeline tracing the history of nanotechnology from medieval glass to the present. See: <http://www.discovernano.northwestern.edu>

The Understanding Nanotechnology website offers an introduction to nanotechnology; explanations of nanotechnology applications, including medicine, fuel cells and food; and a discussion of nanomaterials. See: www.understandingnano.com

For German speakers, Science on Stage Germany has produced a 120 page textbook describing the complexity and diversity of the nano-world, covering research, applications, history, education and job offers. Teaching tips, teaching materials and worksheets are also available. The book costs €2.50. For more information, see: www.scienceonstage.de or use the direct link: <http://tinyurl.com/3yqgasa>

If you found this article useful, you may like to browse the other project-related articles on the *Science in School* website: www.scienceinschool.org/projects

Dr Eleanor Hayes is the editor-in-chief of *Science in School*. She studied zoology at the University of Oxford, UK, and completed a PhD in insect ecology. Eleanor then spent some time working in university administration before moving to Germany and into science publishing, initially for a bioinformatics company and then for a learned society. In 2005, she moved to the European Molecular Biology Laboratory to launch *Science in School*.



Stage lights: physics and drama

Imagine sending music across the room by laser. Sounds impossible, doesn't it? But **Alessio Bernardelli's** students did just that – and then developed a play to explain the science behind it. Here's how to do it.

Images courtesy of Xacto / iStockphoto

To encourage our Year 12 students (ages 16-17) not to consider everyday technology as a 'black box' but to ask themselves how it works, my colleagues and I asked them to research, design and build a modulated laser, based on a cheap commercial laser pen. When they found a plausible design, they were astonished at how simple it was. Even some of the teachers had doubted that it would work.

In fact, it exceeded all our expectations. Not only did the modulated laser send an audio signal across the room, the music received by the light sensor and played on the speaker was loud and clear. Our students were amazed that they had made something that they hadn't even known was possible. In fact, it is quite a simple process and can be used to explain a wide range of physics topics – as our students did in the next stage of their project.

What I like about our device is that it is very cheap and very visual. You could buy a similar device for about £250, but ours cost about £15 to make. Also, you can see exactly how our device is constructed, so that even the

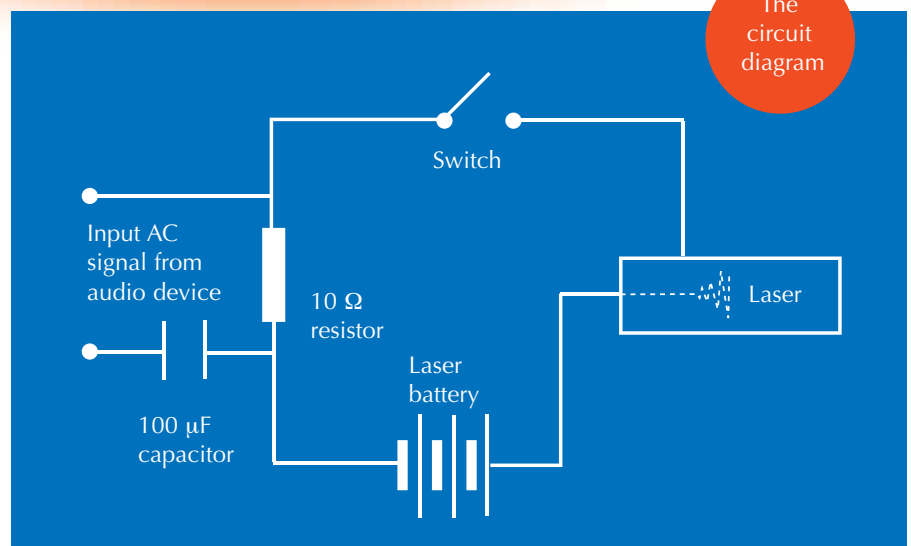

Image courtesy of Alessio Bernardelli

least scientifically minded can see how the circuit is connected.

Building the modulated laser

The input signal from the audio device is sent across a resistor. Because this signal is AC (alternating current), it causes variation in the voltage across the resistor, which in turn causes the overall current in the circuit to change with the same frequency as the input signal. This causes the intensity of light in the laser diode to change with the same frequency.

The laser beam, of varying intensity, is sent to a light sensor attached to a mini-amplifier. Because the number of photons reaching the light sensor changes with the frequency of the audio input signal, the current generated by the light sensor also changes with that frequency. This AC signal is sent to the mini-amplifier, causing the cone of the speaker to move – and we can hear the music.

The capacitor in the modulating circuit is essential to let the AC signal through and prevent the batteries' DC (direct current) from feeding back into the audio device.



- ✔ Physics
- ✔ Ages 13-19

This project is innovative in two main ways. It merges different concepts of physics to produce an alternative use of lasers and then uses a novel pedagogy to facilitate the students' learning of these topics. The students were given the opportunity to be independent and do their own research, producing an amazing result – they managed to link different aspects of physics (electrical circuits, sound waves, light as a means of communication and the photoelectric effect) and devise a system that actually works! The interesting part is that they didn't stop at that, but they shared their project in a very original way: drama. Their script is ingeniously adapted to include complex topics in an action story, to explain those concepts in a simpler, entertaining way.

This article is an ideal guideline for hands-on experience, where students are asked to try building the same circuit or variants of it. It would be a great experience for students to ultimately see it functioning. The apparatus can be easily built, due to the circuit diagram and detailed instructions. The equipment required is usually easily found in physics labs or bought in stores at very reasonable prices. The concepts involved are all discussed at A-level standard

(ages 16-19), hence students can use this opportunity to apply them to a practical situation.

It is important to show students that physics is not only a set of theories listed under compartmentalised topics, but is also a means of explaining incredible phenomena, and can be enjoyable. This article shows how script-writing and role-playing can help students to better understand the topics and to explain them to younger students while showing them that physics can be a source of enjoyment and satisfaction.

For advanced or intermediate physics students (ages 16-19), the project could be used to explain complex electrical circuits and introduce photoelectricity. For younger students (ages 13-15), the simplified concepts in the play can be used to consolidate the topics already learned and give them an insight into what can be learnt at a more advanced level, stimulating their interest and perhaps encouraging them to continue their studies in physics.

It is interesting to see that when physics is made fun and engaging for students, no matter what age, they are better able to understand even the most difficult concepts. As the authors state, students who were previously struggling with physics improved after taking part in this activity. This is impressive and these sorts of projects should be promoted and encouraged.

Catherine Cutajar, Malta

REVIEW

Materials

- Laser pen (at least 5 mW)
- Mini-amplifier
The Radio Shack ones seem to be the best and cheapest¹
- 3.5 mm mono jack lead (one jack plug at each end)
- 3 AAA batteries
- Battery holder for 3 AAA batteries
- Small light switch (press on / press off type)
- Solder and wire
- 2 crocodile clips
- 100 μ F capacitor
- 10 Ω resistor
- Phototransistor or light sensor
- An audio device such as an mp3 or CD player (any audio device that uses a 3.5 mm jack lead)
- 2 stands and clamps



Image courtesy of Alessio Bernardelli



The materials required



Images courtesy of Alessio Bernardelli

Assembly

The modulating circuit

1. Open the laser pen and remove the batteries.
2. Attach one crocodile clip to the battery spring inside the laser pen.
3. Attach the other crocodile clip to the case of the laser pen; do not let the clips touch each other.
4. If the laser beam does not work when the circuit is complete, swap the crocodile clips on the spring and the case (the laser diode only works if the current is flowing in the right direction).
5. Solder a wire to connect one of the crocodile clips to one end of the battery holder.
6. Solder a wire to connect the other end of the battery holder to the resistor.

This completes the DC part of your circuit, but to modulate the laser beam you must alter the voltage across the resistor, so that an AC will be generated and superimposed on the DC from the laser diode battery.

7. Cut the double jack lead in half. At one of the cut ends, strip the coating off the wire. (Save the other half of the lead for the receiver, see page 44).

8. You will see that the lead is made of thin copper wires wrapped around another wire covered in rubber. Gather all the thin copper wires, separating them from the rubber-covered central wire (you might need to strip the rubber off to expose the central wire).
9. Solder one of the two wires (either the bunch of thin copper wires or the central wire; it does not matter which) to one end of the capacitor.
10. Solder wires to connect the other end of the capacitor to the resistor.
11. To complete your modulated laser pen, solder the remaining wire

from the jack lead to the opposite end of the resistor.

12. Using the jack plug, you can now connect your laser pen to the audio device.

The receiver

1. Strip the coating from the wires in the other jack lead, as in steps 7 and 8.
2. Solder one of the two wires (it does not matter which) to one end of the light sensor, and the other wire to the other end.
3. Use the jack lead, plug the light sensor into the mini-amplifier and the receiver is finished.



Image courtesy of Alessio Bernardelli



The completed receiver

Our Year-12 students wrote an amusing script, full of sound physics and with plenty of audience participation. It was aimed at Year-9 students (ages 13-14), to make them appreciate physics more – and encourage them to consider studying physics at school or even university.

During the course of the play, the older students explained concepts from the GCSE curriculum (ages 14-16), including signal modulation, the visible spectrum as a means of communication, optical fibres and the reflection of light, as well as some more advanced topics such as the photoelectric effect. The script, which can be downloaded^{w2}, is self-explanatory and shows clearly how the concepts were presented.

The students not only performed the play in our own school but also visited other schools in Wales. The audience was impressed by the quality of the play, the students' knowledge and their ability to transmit it effectively to younger people. The younger students in the audience thought it was a fun way to learn physics and liked the fact that older pupils rather than teachers were showing them these concepts.

The Year-12 students' attitudes also changed. One girl commented that it was only after she scripted and presented the photoelectric effect to younger students that she started to really understand the phenomenon. This is a common experience for teachers: it is only when we have to teach the topics that we start to understand them thoroughly ourselves. Partly as a result of this project, all of the Year-12 students involved chose to study physics or engineering at university.

The legacy of the project

The project started in June 2008 but its effects are still being felt. When we visited other schools, our play was not only for the Year-9 students, but also for their teachers. It demonstrat-



Image courtesy of Alessio Bernardelli

The device in action. The laser is coming towards the camera and hits the light sensor held to the wooden block by sticky tape. The haziness is caused by a smoke machine to make the beam visible

Operation

Point the laser beam at the light sensor, aligning them carefully using clamps and stands at both ends.

Switch on the audio device. The music will be played by the mini-amplifier – to which it is transferred via the laser. To make the demonstration even more dramatic, connect the output of the mini-amplifier to a more powerful speaker.

Safety note: Even relatively small amounts of laser light can lead to permanent eye injuries, so make sure you follow the safety instructions with your laser pen.

Communicating the physics

So we'd built a great gadget, but what were we going to do with it? My colleagues and I thought the students could design an interactive lecture show – but they came up with a much more creative idea. They decided to write a play based on James Bond, using situations in the play to explain the physics concepts behind our device.

Matt Smith



Image courtesy of Matt Smith

Image courtesy of Alessio Bernardelli

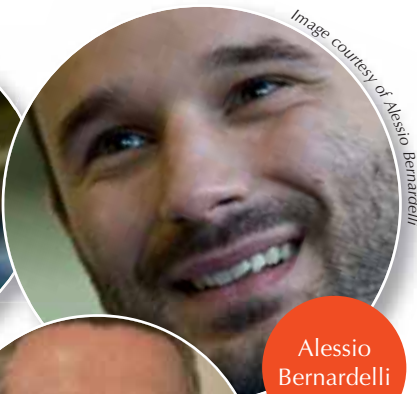

Alessio Bernardelli

John Ivins



Image courtesy of John Ivins

ed how much physics can be explained with our device; and because we presented them with their very own modulated laser pen, they could do similar demonstrations with their own classes. And of course, my colleagues at Croesyceiliog School^{w3} continue to use the device in their own lessons.

The impact of the project also extended beyond our region of Wales. In October 2008, together with some of our students, we ran a hands-on workshop for teachers at the Welsh Physics Teachers' Conference, organised by the UK's Institute of Physics^{w4}.

In April 2009, Science Made Simple^{w5} visited our school and incorporated aspects of our project into their new show for primary and secondary schools, taking our project even further afield – across England and Wales.

Timing

The project ran for a whole year, as part of the Rolls-Royce Science Prize 2008-09^{w6}, for which we were one of nine finalists. The research and design stage took a couple of weeks, and the device itself was built in a few days. The theatre phase – writing the script, rehearsing and giving the performances – took about two months. Over the course of the rest of the year, we collaborated with the Institute of Physics and Science Made Simple.

During school hours, we devoted about two months of one-hour lessons (two per week) to the project. The rest of the work was done after school.

Acknowledgements

Alessio Bernardelli led the project, but it would not have been possible without the help of Matt Smith and John Ivins, colleagues at Croesyceiliog School.

At the time of the project, Matt was an exceptional trainee teacher at Croesyceiliog School. He played an essential role in the design of the circuit, and solved many problems that arose during the course of the project. He is now the director of physics in an international school in Rome, Italy.

John Ivins was a key member of the team thanks to his rapport with the students. He is currently the acting head of physics at Croesyceiliog School in Cwmbran in Wales, UK.

Web references

w1 – We used a Radio Shack mini audio amplifier, which can be purchased from T2Retail (T2 product reference number 2771008): www.t2retail.co.uk

w2 – The script of the play and the Powerpoint presentation used during it can be downloaded from the *Science in School* website: www.scienceinschool.org/2010/issue17/laser#resources

w3 – To learn more about Croesyceiliog School, see: www.croesyceiliog.org.uk

w4 – The UK's Institute of Physics teacher network provides support for physics teachers across Great Britain and Ireland. See: www.iop.org/education

w5 – Science Made Simple offers inspirational and educational shows for schools and festivals, and

develops educational materials about science. See: www.sciencemadesimple.co.uk

w6 – The Rolls-Royce Science Prize helps teachers in the UK to implement science teaching ideas in their schools and colleges. For details, see <http://science.rolls-royce.com>

w7 – The National Grid for Learning Cymru^{w7} provides nearly 3000 downloadable educational resources to all stages of Welsh school education. For more details, see: www.ngfl-cymru.org.uk

w8 – The Microsoft Innovative Teachers Forums are a set of national, regional, and worldwide events that identify and reward exceptional examples of technology use in the classroom. For more details, see: www.microsoft.com/education

Resources

For more details of the project, see the report on Alessio Bernardelli's blog: <http://alessiobernardelli.wordpress.com/page/2>

You can also follow his activities via Twitter: <http://twitter.com/asober>

To browse other *Science in School* articles about science education projects, see: www.scienceinschool.org/projects

At the time of the project, Alessio Bernardelli was the deputy team leader of science at Croesyceiliog School in Cwmbran, Wales, UK. He taught science to 11- to 14-year-olds, and physics to the older students (ages 14-18).

He is now a field officer for the National Grid for Learning in Wales^{w7} and the coordinator of the Institute of Physics teacher network^{w4} in Gloucestershire. In 2007, he was an award winner at the Microsoft Worldwide Innovative Teachers Forum^{w8} held in Helsinki, Finland.



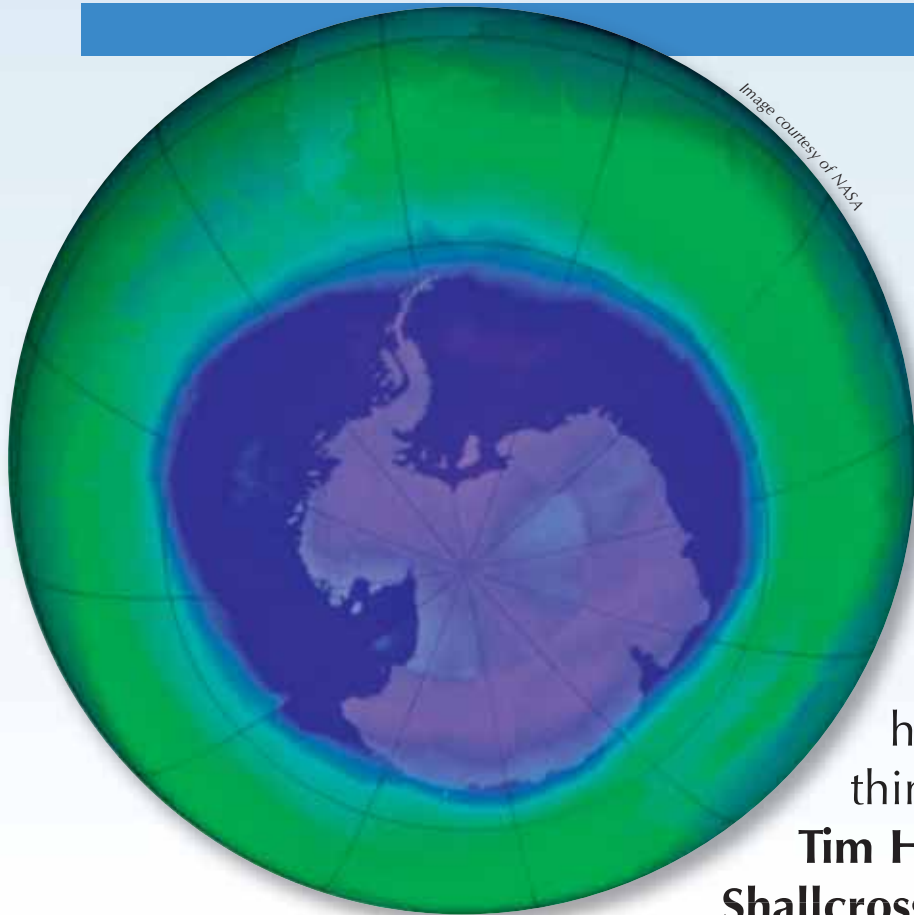

A hole in the sky

Twenty-five years ago, the discovery of the hole in the ozone layer hit the news. How have things developed since?

Tim Harrison and Dudley Shallcross investigate.

The Antarctic ozone hole at its annual maximum on 12 September 2008, stretching over 27 million square kilometres. This is considered a moderately large ozone hole, according to NASA

Discovering the hole

It was a serendipitous find, as Jonathan Shanklin, one of the hole's discoverers, remembers: having joined the British Antarctic Survey^{w1} in 1977, he was supposed to digitise their backlog of ozone measurements – until then, handwritten data sheets. As it turned out, this included the crucial decade, the 1970s, when ozone levels began to drop.

There had already been growing concern that industrial chlorofluorocarbons (CFCs) – organic compounds such as trichlorofluoromethane (CFCl₃) and dichlorodifluoromethane (CF₂Cl₂), then widely used as refrigerants, propellants (in spray cans) and solvents – might destroy the ozone layer. For an open day in 1983, Shanklin prepared a graph – ironically to show that the ozone data from that year were no different from 20 years before. Although this was true for the overall ozone levels, he noticed that the springtime values did look lower from one year to the next. Further studies corroborated this, and in 1985 Shanklin and his colleagues Joe Farman and Brian Gardiner published their findings: each Southern Hemisphere spring, a hole gaped in the ozone layer above the Antarctic, it was probably caused by CFCs, and it was growing (Farman et al., 1985).

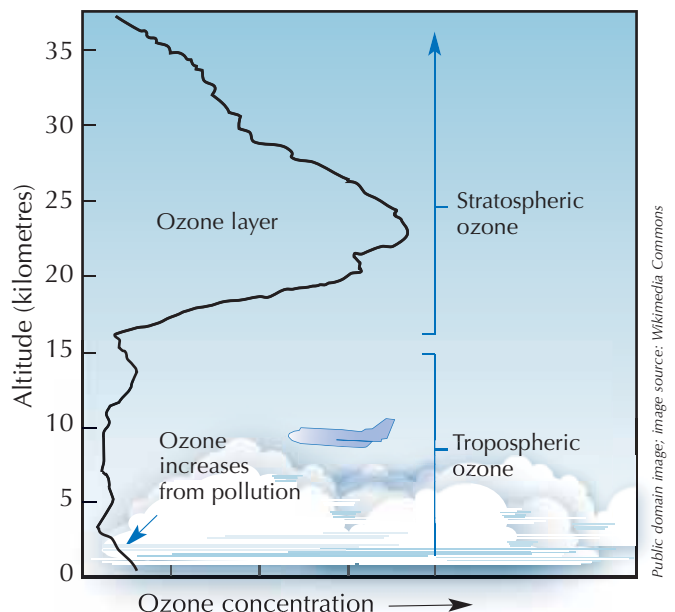

Ozone is present throughout the lower atmosphere. Most ozone is in the stratospheric ozone layer. Near Earth's surface, the ozone levels increase as a result of pollution from human activities

What is the chemistry behind this, and why is the ozone hole dangerous?

Ozone in the stratosphere

Ozone (O₃) is a much less stable triatomic form of oxygen (O₂). It is a pale blue gas present at low concentrations throughout the atmosphere – and a double-edged sword: in the troposphere (see image on page 48), ozone is an air pollutant which can damage the respiratory systems of humans and other animals and burn sensitive plants. The ozone layer in the stratosphere, however, is beneficial, preventing most of the harmful ultraviolet (UV) light emitted by the Sun from reaching Earth's surface.

The rate of ozone formation maximises in the stratosphere, the second highest layer of Earth's atmosphere (at about 10-50 km altitude; see image), through a photochemical mechanism:



An oxygen molecule (O₂) absorbs a photon of UV light

($h\nu$) with a wavelength (λ) around 200 nm and dissociates into two oxygen atoms (O \bullet) (reaction 1). Each of these can then combine with another oxygen molecule to form ozone, if the pressure (M) is high enough (approximately one thousandth of an atmosphere) to stabilise the newly formed ozone molecule (reaction 2). The higher the altitude, the faster the rate of reaction 1 (below 20 km altitude, no 200 nm photons occur because they have all been absorbed in reaction 1). The rate of reaction 2, however, is faster closer to the ground, where atmospheric pressure is higher. As a result, the maximum amount of ozone is created between about 25 and 30 km altitude (see graph on page 46).

The stratosphere has two important consequences for life on Earth. First, ozone itself absorbs high-energy UV radiation at around 250 nm (reaction 3):



Between them, oxygen (reaction 1) and ozone (reaction 3) therefore filter out of the atmosphere most of the short-



✓ Earth sciences

✓ Ages 16+

The ozone hole is a topical global issue, and you will find this article really helpful to get into the subject. The chemical processes involved are described in full detail. In chemistry lessons, the article can be used to teach atomic structure and chemical bonds, free radicals, catalytic cycles, and the influence of light and temperature on chemical reactions.

For the earth science classroom, the article would fit in the context of the following topics:

- Atmospheric influence on climate
- Biological processes occurring on Earth's surface and affecting marine organisms
- Earth's morphology and the distribution of mountain ranges on Earth's surface
- The changing of the seasons, Earth's axial tilt and rotation.

There is the opportunity for interdisciplinary work linking chemistry and earth sciences. Possible topics include:

- The geographical distribution of the organisms that produce chemicals that are active in natural

catalytic cycles. Where do those organisms live? Which chemical substances do they produce?

- The chemical composition of the atmosphere and its influence on the climate. Which gases is the atmosphere composed of? In which way do the atmosphere's properties determine climatic conditions on Earth's surface, and how does this differ on other planets?

The article could also form the basis of a lesson on how science is reported in the media. Students could compare this article to those in the general press: do they provide a balanced view of the question, mentioning both chemical and natural components leading to the formation of the ozone hole? Do they minimise or overemphasise the phenomenon as a whole? Why – due to journalists' ignorance, political strategy or both? For further ideas on using news in the science classroom, see Veneu-Lumb & Costa (2010).

Finally, the text is suitable as the basis of a comprehension exercise, too. Possible questions are:

- Why is this topic a much debated question nowadays?
- What is the role of natural factors in the growth of the ozone hole? What about human factors?

Teresa Celestino, Italy

Layers of atmosphere leading to space

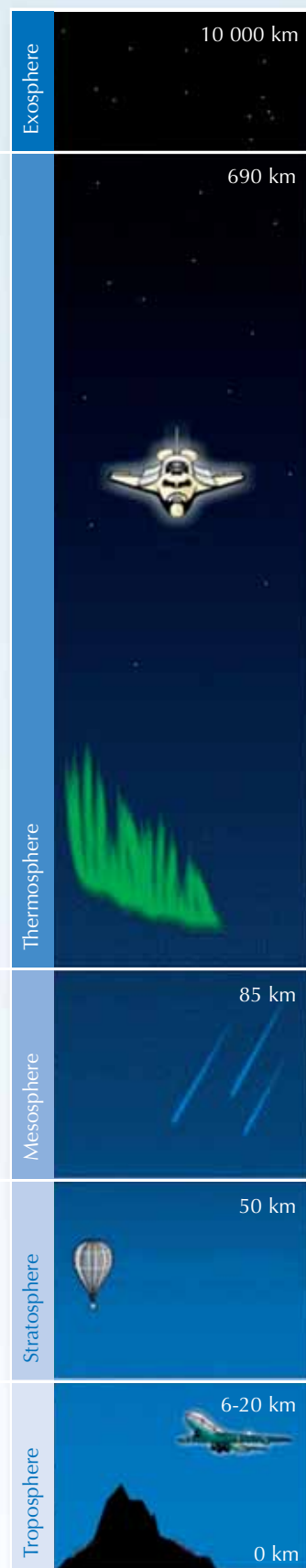

Public domain image: Image source: Wikimedia Commons

Image courtesy of Marlene Rau

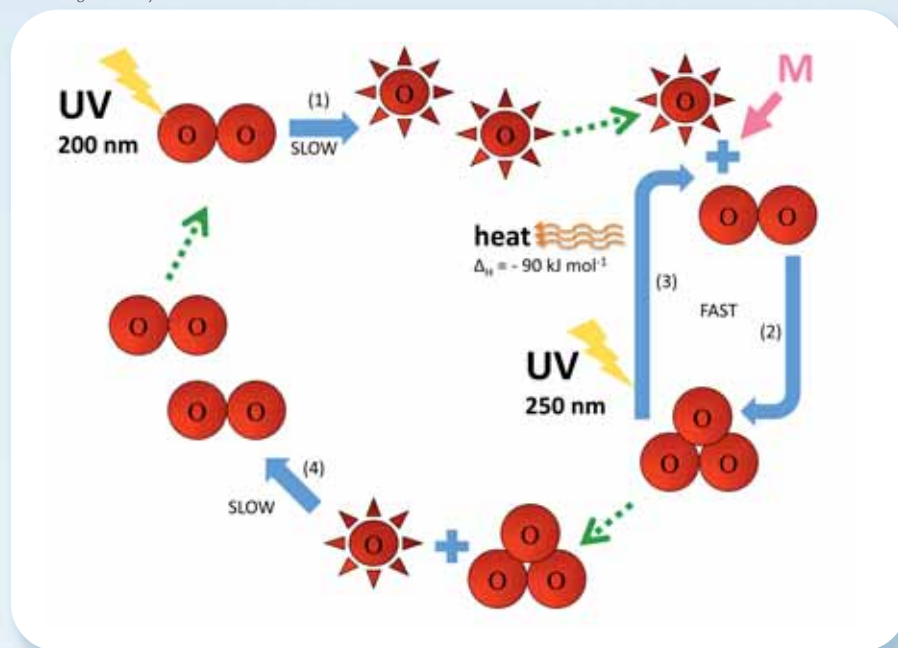

The four main reactions of oxygen in the ozone layer. Blue arrows indicate reactions, green dotted arrows indicate that a molecule from one reaction goes on to take part in another reaction. M denotes the pressure required for reaction 2

wave UV radiation between 200 and 300 nm, which would otherwise be very damaging to life on Earth.

Second, reaction 3 produces a lot of heat, so the stratosphere is a warmer layer than the top of the troposphere (see image left), making the weather in the troposphere less extreme than it would otherwise be.

Reactions 2 and 3 rapidly interconvert oxygen atoms and ozone. There is another slow reaction, though, which is known to destroy both oxygen atoms and ozone, namely the reaction between these two species:



Reactions 1-4 are summarised in the diagram above.

Natural catalytic cycles reduce the levels of ozone

In 1995, Paul Crutzen, Mario Molina and F Sherwood Rowland were awarded the Nobel Prize in Chemistry for their work on the formation and decomposition of ozone in the stratosphere. What had they learned? In the 1970s, Crutzen and others discovered the existence of natural catalytic cycles that speed up reaction 4 and reduce the amount of ozone in the stratosphere (Crutzen, 1970, 1971): water (H_2O), methane (CH_4), nitrous oxide (N_2O) and chloromethane (CH_3Cl) are released into the atmosphere from biological processes occurring on Earth's surface, and lead to the formation of radicals such as hydroxyl ($\text{OH}\bullet$), nitric oxide ($\text{NO}\bullet$) and chlorine ($\text{Cl}\bullet$), which catalyse the decomposition of ozone.

Reaction 5 shows how chloromethane releases chlorine radicals into the stratosphere through photolysis, and reactions 6 and 7 are an example of a catalytic cycle (see diagram on page 49). The reactions of the other catalysts are analogous with reactions 6 and 7. Chloromethane is released in part by both marine and terrestrial organisms, such as red macroalgae, white rot fungi and higher plants, to regulate chloride ion levels in the cells and – after 30 to 40 years – can reach the upper stratosphere (around 40 km altitude) where it is broken down by sunlight (photolysis):

Image courtesy of Marlene Rau

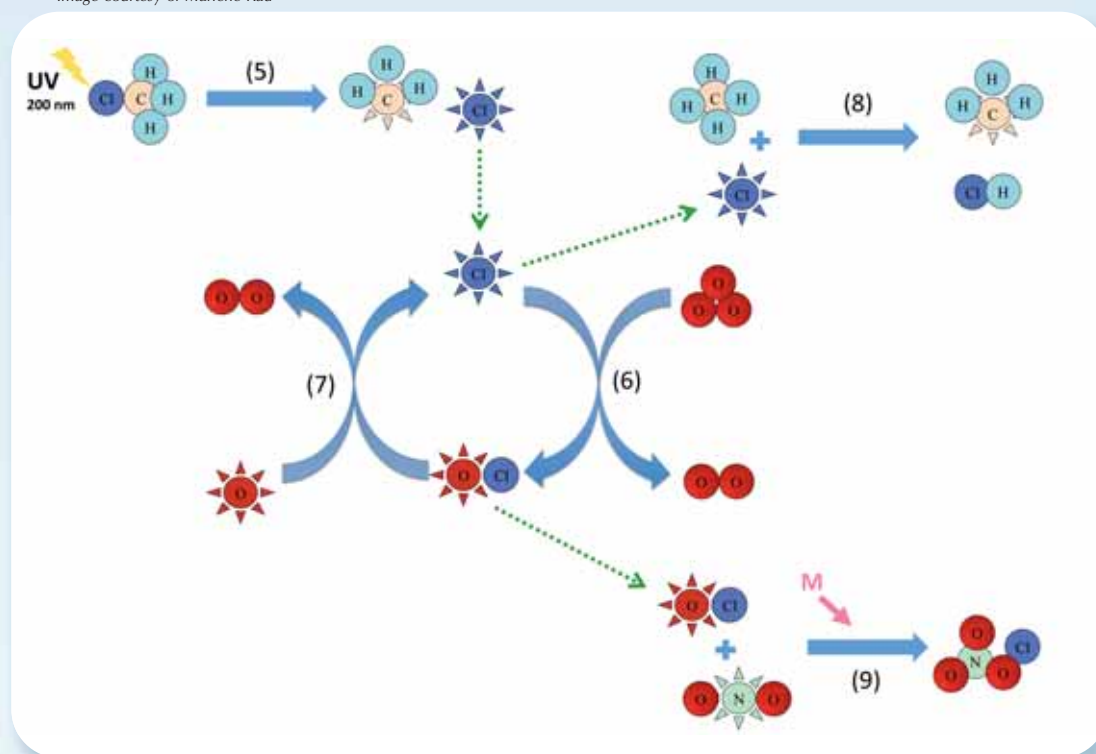

Chlorine radicals (for example from reaction 5) enter a catalytic cycle (reactions 6 and 7) of net ozone decomposition, which can be terminated by reactions 8 and 9. Blue arrows indicate reactions, green dotted arrows indicate that a molecule from one reaction goes on to take part in another reaction. M denotes the pressure required for reaction 9



The resulting chlorine free radical ($\text{Cl}\bullet$) can then participate in a catalytic cycle:

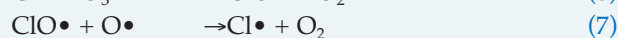
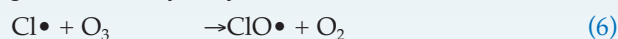

Reactions 6 and 7 taken together are in fact equivalent to reaction 4, but happen much faster – in the case of the chlorine / chlorine monoxide ($\text{ClO}\bullet$) radical cycle, about 30 000 times faster. So why do these catalytic cycles not destroy all the ozone? The answer lies in the termination of these cycles via the formation of stable molecules:

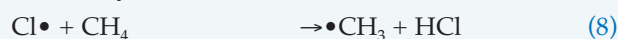

Eventually, a chlorine free radical will encounter a methane molecule and react to form hydrochloric acid (HCl , reaction 8). Similarly, a chlorine monoxide radical will bind to a nitrogen dioxide radical, forming chlorine nitrate (ClONO_2 , reaction 9) – another pressure-dependent reaction that therefore works better at lower altitudes. Both hydrochloric acid and chlorine nitrate are very stable, and the removal of chlorine and chlorine monoxide radicals eventually stops the catalytic cycle.

The Antarctic ozone hole puzzle

It was not long before scientists realised that CFCs could trigger a similar catalytic cycle of ozone degradation: in 1974, Molina and Rowland not only warned that levels of CFCs continued to increase without regulation, but also

predicted that CFCs would cause a significant additional loss of ozone at around 40 km altitude (see Molina & Rowland, 1974). However, when the ozone hole was finally found in 1985, it was in fact at around 20 km altitude, over the South Pole in the Southern Hemisphere spring-time (see Farman et al., 1985).

It soon emerged that chlorine free radicals from the CFCs were responsible, but many questions remained unanswered. Why did the hole occur over the Pole? If it occurred over the South Pole, why not also over the North Pole? Why only in spring? And why was the ozone hole at 20 km altitude instead of at 40 km, as predicted? After all, CFCs could not be broken down by sunlight at an altitude as low as 20 km, since the photon density was insufficient. For the same reason, not enough oxygen atoms are produced at this altitude for reaction 7 to occur. Many years of further research revealed the complete story.

First, chlorine free radicals released from the CFCs, e.g.



could react with methane (reaction 8) forming hydrochloric acid, or with ozone (reaction 6) forming chlorine monoxide radicals, and through reaction 9 could subsequently form chlorine nitrate. This sequence of reactions would increase the concentrations of hydrochloric acid and chlorine nitrate at around 40 km altitude globally.

Each Southern Hemisphere winter, the South Pole is plunged into darkness for approximately three months. The air in the stratosphere above the South Pole cools

All year round over the Equator,
in summer and autumn over the South Pole

Early winter

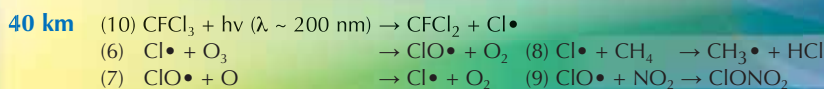

30 km

20 km

Equator

HCl and
ClONO₂
Vortex forms

Cold and dark
air sinks

The formation and dissolution of the ozone hole over the year. Reactions 5 to 9 happen over the Equator all year round, and over the South Pole in summer and autumn. In early winter, the vortex forms over the South Pole, followed by the formation of polar stratospheric clouds in winter. In early spring, the sunshine returns, but the vortex remains, and the reactions leading to ozone removal over the South Pole take their course. In late spring, the vortex breaks down, and ozone from mid-latitudes can mix in

down; without UV radiation, reaction 3 does not occur, so no heat is released. The air sinks and Earth's rotation causes it to spin and form a vortex as it does so, like water going down a plughole. This vortex is so strong that no air from outside can get in, and no air from inside can get out. Air that is rich in hydrochloric acid and chlorine nitrate from 40 km altitude is drawn down into this cold and dark vortex.

In the extreme cold of the polar winter, the air in this vortex becomes so cold that below -78°C (195 K) and at an altitude of 15-25 km, polar stratospheric clouds form from water and / or acid ice crystals.

The first peculiar bit of chemistry is that hydrochloric acid and chlorine nitrate can adsorb onto polar stratospheric clouds and undergo a fast heterogeneous reaction from gaseous to solid phase, producing nitric acid (HNO_3) that becomes incorporated into the ice crystals, whilst the chlorine (Cl_2) is released back into the gas phase.

$\text{HCl} + \text{ClONO}_2 \rightarrow \text{HNO}_3 + \text{Cl}_2$ polar stratospheric clouds (11)

This reaction can take place all winter, if it is cold enough to form polar stratospheric clouds. When the sunshine returns in spring, there are plenty of chlorine molecules at around 15-25 km altitude, which are photolysed to produce chlorine radicals:



and subsequently chlorine monoxide radicals via reaction 6.

However, in the polar spring, reaction 7 (the formation of chlorine radicals and oxygen molecules from chlorine monoxide radicals and oxygen radicals) is very slow, since there are so few oxygen atoms present due to the lack of 200 nm photons at this altitude, and here is where a second peculiar piece of chemistry occurs. At low temperatures, such as in the polar vortex – which is still very cold even in spring – chlorine monoxide radicals can form a

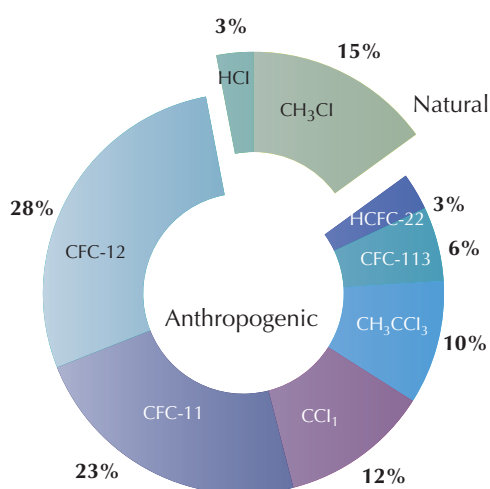

Sources of stratospheric chlorine according to the WMO / UNEP Scientific Assessment of Ozone Depletion: 1998



Polar stratospheric clouds in Asker, Norway

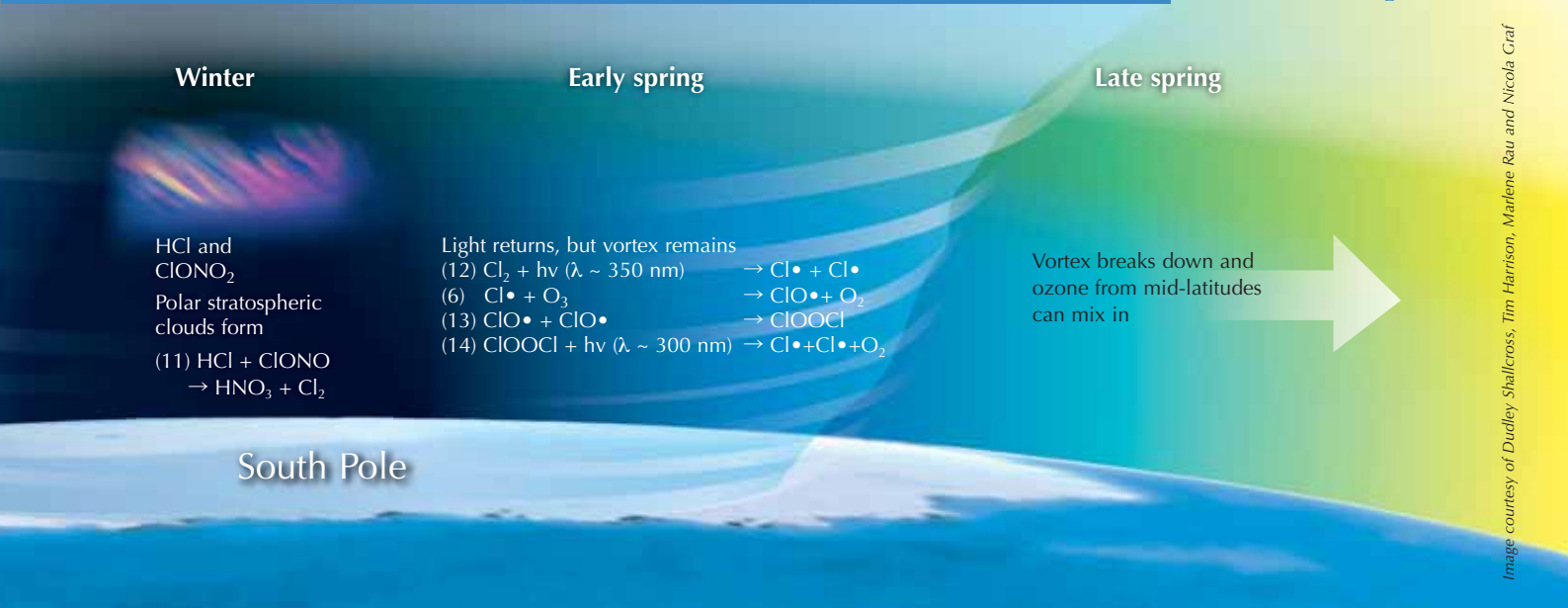

dimer, chlorine peroxide (ClOOC1):



This dimer is unstable at room temperature but forms quite readily at low temperatures (below $-30\text{ }^{\circ}\text{C}$) and can be photolysed:



So even though reaction 7 cannot occur, reaction 14 provides a way to regenerate chlorine free radicals with the help of light, and the catalytic cycle for ozone depletion can start in earnest now that the sunshine has returned.

In what way does this differ from the natural catalytic cycles we looked at before – why is there a total removal of ozone at some altitudes in this vortex? First, reaction 8 (which removes chlorine radicals and can terminate the cycle) is very slow at the low temperatures found in the vortex, and therefore ineffective. Second, all the nitrogen dioxide required for reaction 9 (which could likewise terminate the cycle, through the formation of ClONO_2) has been converted to nitric acid throughout the winter (e.g. through reactions 9 and 11) and it is not available to be regenerated since there is no upward flow in the vortex (at the base of the vortex, air flows from the South Pole to the Equator, where the upward flow takes place). Therefore the cycle carries on unchecked and destroys all the ozone at that level. Finally, without ozone, reaction 3, which would otherwise warm this region, is absent, and so the vortex lasts well into the spring, exacerbating the ozone depletion.

The only reason that the ozone hole is more severe over the South Pole than the North Pole is that the spring temperatures in the stratosphere above the North Pole are slightly warmer than those above the South Pole, because there are more mountain ranges in the mid to high latitudes of the Northern Hemisphere, which change the dynamics of atmospheric flow, so there are fewer polar stratospheric clouds.

In late spring, the flow of ozone-rich air from above eventually warms the vortex via reaction 3, allowing the vortex to eventually break down. Since exchange with other parts of the atmosphere then becomes possible again, the ozone hole is filled with ozone from the surrounding air.

In some years, the ozone hole over Antarctica has grown large enough to reach Australia, New Zealand, Chile and Argentina, growing to 1.5 times the size of the USA; and when the ozone hole breaks up, the ozone-depleted air drifts out into nearby (populated) areas, including South Africa. For the people in these countries, the ozone hole poses a direct health threat. The main concern is the increased exposure to UV, which may cause skin cancer and ocular cortical cataracts, as well as damage to the immune system. Furthermore, excessive UV radiation damages plants and building materials.

CFCs and ozone today

Today, we have a good understanding of the physics and chemistry governing the ozone layer. Once the true impact of CFCs on ozone depletion became apparent, governments passed regulations to stop the use of CFCs, replacing them with alternative, shorter-lived, species (hydrofluorocarbons and hydrochlorofluorocarbons), which were to be phased out eventually too: the Montreal Protocol of 1987 and especially its amendments in 1990 and 1992, which speeded up the phase-out, were an environmental success.

The most recent data from AGAGE (The Advanced Global Atmospheric Gases Experiment)^{w2}, which has been monitoring levels of CFCs and their replacements since 1978, shows that even the atmospheric levels of dichlorodifluoromethane (CF_2Cl_2), the longest-lived CFC, are now decreasing: the legislation has been effective (see graph on page 52). An ozone hole still forms each spring over the South Pole, but estimates are that by 2050 this will no

longer happen, and that by 2080 the global ozone will return to 1950s levels.

The ozone hole is the result of an increased use of CFCs, which began in the 1930s – like any other gas, CFCs take 30-40 years to reach the upper stratosphere, which means that there is a corresponding lag in their effect on the ozone layer. We are currently experiencing the stratospheric chlorine peak resulting from the highest levels of CFC use in the 1980s – so the maximum size the ozone hole reaches each year should begin to decrease a few years from now.

Although recovery is slow, we have definitely stopped a disaster: scientists have calculated that if the use of CFCs had continued at its 1970s growth rate of 3% per year, this would have led to a global ozone hole by 2060, with all the health problems that would bring (see image on page 53; Newman et al., 2009).

Perhaps the most important lesson to be learned from the ozone hole is just how quickly our planet can change as a result of human impact – especially for the worse, but also for the better – and that change is possible if we take action concertedly, effectively and quickly.

References

- Crutzen PJ (1970) Influence of nitrogen oxides on atmospheric ozone content. *Quarterly Journal of the Royal Meteorological Society* **96**: 320-325. doi: 10.1002/qj.49709640815
- Crutzen PJ (1971) Ozone production rates in an oxygen-hydrogen-nitrogen oxide atmosphere. *Journal of Geophysical Research* **76(30)**: 7311-7327. doi: 10.1029/JC076i030p07311
- Farman JC, Gardner BG, Shanklin JD (1985) Large losses of total ozone in Antarctica reveal seasonal ClO_x/NO_x interaction. *Nature* **315**: 207-210. doi: 10.1038/315207a0
- The article is freely accessible on the *Nature* website (www.nature.com) or via the direct link: <http://tinyurl.com/2wemxhn>

The atmospheric concentration of CFCs increased rapidly and is now slowly decreasing again. Data are given for CF₂Cl₂, at the five AGAGE surface measurement stations from 1978 to the present day, taken from the AGAGE website⁹² in September 2010

Image courtesy of AGAGE

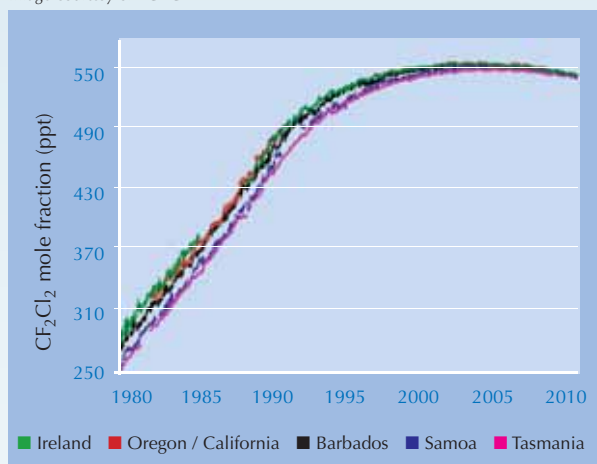

- Molina MJ, Rowland FS (1974) Stratospheric sink for chlorofluoromethanes – chlorine atomic-catalysed destruction of ozone. *Nature* **249**: 810-812. doi: 10.1038/249810a0
- The article is freely accessible on the *Nature* website (www.nature.com) or using the direct link: <http://tinyurl.com/2u69cul>
- Newman PA et al. (2009) What would have happened to the ozone layer if chlorofluorocarbons (CFCs) had not been regulated? *Atmospheric Chemistry and Physics* **9**: 2113-2118. doi: 10.5194/acp-9-2113-2009
- Patterson L (2010) A chemical bond: Nick Barker, linking schools and universities in the UK. *Science in School* **15**. www.scienceinschool.org/2010/issue15/nickbarker
- Veneu-Lumb F, Costa M (2010) Using news in the science classroom. *Science in School* **15**: 30-33. www.scienceinschool.org/2010/issue15/news

Web references

- w1 – The British Antarctic Survey is responsible for the UK's national scientific activities in Antarctica. See: www.antarctica.ac.uk
- w2 – The Advanced Global Atmospheric Gases Experiment, AGAGE, is a NASA-sponsored initiative that has been measuring the composition of the global atmosphere continuously since 1978,

including CFCs and most non-CO₂ greenhouse gases specified in the Kyoto protocol. To access their data and for more information, see: <http://agage.eas.gatech.edu>

Resources

- Sidney Chapman first derived the photolytic mechanism by which ozone is formed and degraded. See: Chapman S (1930) On ozone and atomic oxygen in the upper atmosphere. *Philosophical Magazine Series 7* **10(64)**: 369-383. doi: 10.1080/14786443009461588
- Jonathan Shanklin, one of the scientists who discovered the ozone hole, published his reflections 25 years after the discovery: Shanklin J (2010) Reflections on the ozone hole. *Nature* **465**: 34-35. doi: 10.1038/465034a.
- Download the article free of charge from the *Science in School* website (www.scienceinschool.org/2010/issue17/ozone), or subscribe to *Nature* today: www.nature.com/subscribe
- Nature* has also published a collection of articles that have advanced our understanding of the stratosphere and the ozone layer, or told the story of the discovery, some of which are freely available. See: www.nature.com/nature/focus/ozonehole

NASA images courtesy of the Goddard Space Flight Center Scientific Visualization Studio

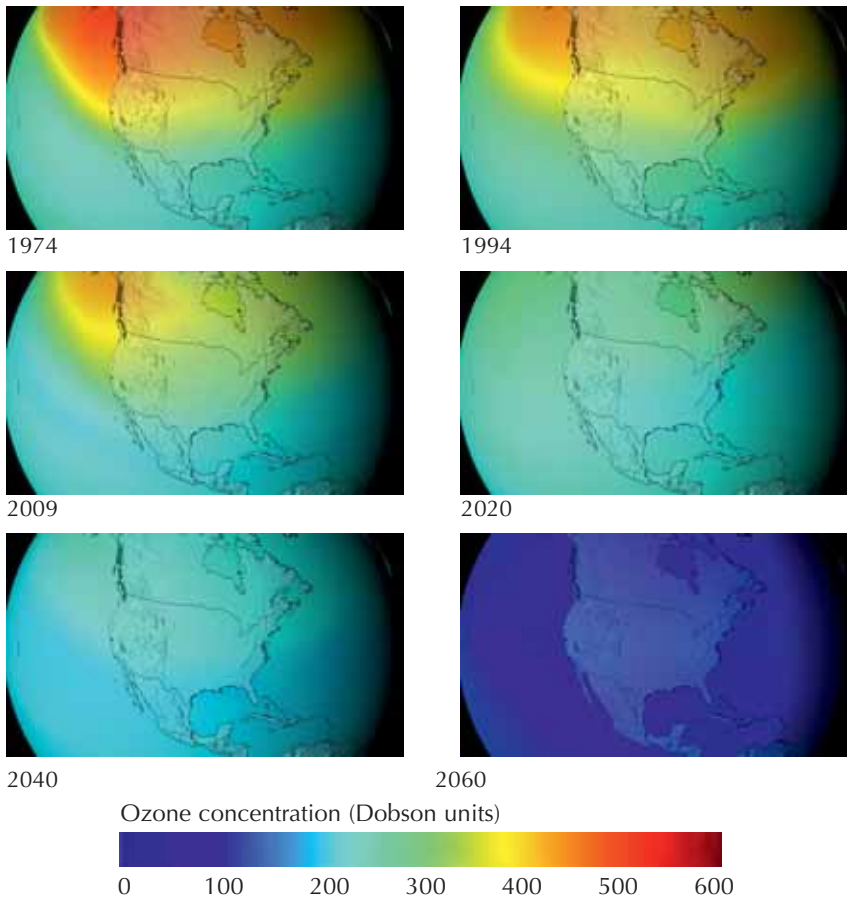

This is how the ozone layer would look if CFCs had not been banned

NASA's Ozone Hole Watch page offers historical ozone maps, ozone facts, an ozone-related multimedia gallery, a collection of teaching modules about ozone-related topics, and more. See:

<http://ozonewatch.gsfc.nasa.gov>

The University of Cambridge, UK, has compiled a virtual tour of the ozone hole, its history and science. The tour is available in English, French and German. See: www.atm.ch.cam.ac.uk/tour or use the direct link:

<http://tinyurl.com/2wvpvf9r>

The 74 scientists who attended the panel review meeting for the 2002 ozone assessment in Les Diablerets, Switzerland, published *20 Questions and Answers about the Ozone Layer*, including the contributions of cycles of solar activity and volcanic

eruptions. See: www.gcrio.org or use the direct link:

<http://tinyurl.com/2wvpvf9r>

Introduction to Atmospheric Chemistry by Harvard University's Professor Daniel J Jacob, which is freely accessible as a PDF, contains a section on ozone, including the diagram 'Chronology of the ozone hole' (chapter 10.3.3). See:

<http://acmg.seas.harvard.edu> or

use the direct link:

<http://tinyurl.com/39vhy6a>

Ozzy Ozone is a United Nations Environment Programme website offering educational cartoons, games, a glossary and more – including downloadable education packs with student and teacher handbooks for both primary and secondary school. All material is available in English, French, and Spanish. See: www.ozzyozone.org

The Ozone Depletion website by scientist and author Rod Jenkins contains comprehensive information: www.ozonedepletion.info

The website of the United Nations Environment Programme's OzonAction branch provides a large collection of data and information about ozone and the Montreal Protocol. See: www.unep.fr/ozonaction

See also the pages of the United Nations Environment Programme Ozone secretariat, in English, French and Spanish: <http://ozone.unep.org>

NASA offers two online videos of atmospheric developments over the Arctic, as measured with the Upper Atmosphere Research Satellite (UARS).

You can watch the increasing concentration of chlorine nitrate in February / March 1993. See www.nasaimages.org or use the direct link:

<http://tinyurl.com/2w6wgh4>

This video shows the formation of polar stratospheric clouds. See www.nasaimages.org or use the direct link:

<http://tinyurl.com/33dfn6e>

In addition, NASA has published images of a season in the life of the ozone hole. See: www.nasa.gov/vision/earth/lookingatearth/25TOMSAGU.html

For the complete list of climate-related articles published in *Science in School*, see: www.scienceinschool.org/climate

Dudley Shallcross is a professor in atmospheric chemistry and Tim Harrison is a school teacher fellow at the School of Chemistry, University of Bristol, UK. For more information about the post of school teacher fellow, see Patterson (2010).



Clouds: puzzling pieces of climate

The physics of clouds and their role in our climate have perplexed scientists for decades. **Karin Ranero Celius** investigates.

Image courtesy of Olaf Brust

Do clouds affect our climate, or does the climate have an effect on clouds? Both are true. However, clouds are so difficult to understand that they are not yet well incorporated into climate models. That would require us to understand how clouds form, why they appear and disappear, and why and when they precipitate. To this end, scientists must analyse the behaviour of individual clouds, their components and their effect on the surroundings.

Essentially, clouds are visible masses of water droplets (or even crystals), suspended in Earth's atmosphere. To study them, researchers divide them into categories. Thin and wispy clouds are called *cirrus* clouds.

Image adapted from Russell et al. (2007); courtesy of the Institute of Physics

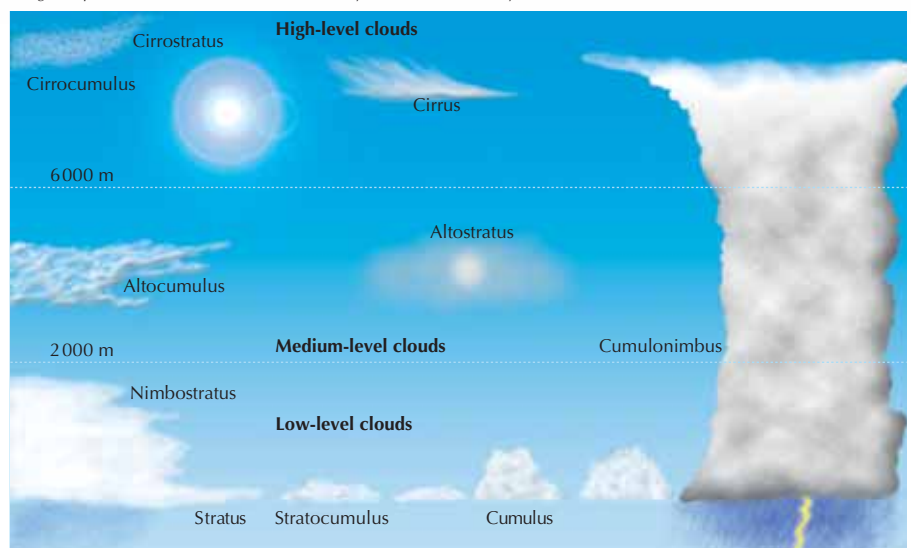

Clouds are classified into different categories

Image courtesy of Stephan Borrmann

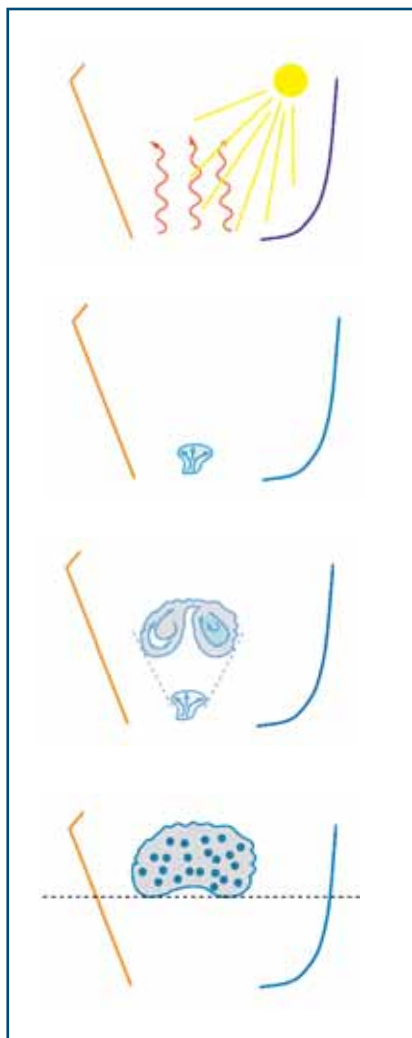

Formation of clouds by convection (rising air): sunlight heats the ground so that the air above heats up and rises. With increasing altitude, it expands and cools until the vapour condenses. Turbulent flow mixes the moist cloud air with the surroundings so that low-level cumuli sometimes disperse again (third image). Temperature and pressure decrease with altitude, as illustrated at the left and right edges



- ✓ Geography
- ✓ Physics
- ✓ General science
- ✓ Ages 10-19

At a time when many countries worldwide are working together to increase the use of renewable resources and reduce climate change and its effects as much as possible, this article brings a new perspective. The author provides detailed and interesting information about the relationship between clouds and climate change, giving examples from various parts of Earth.

The article can be used for several science subjects, such as:

- General science: formation of clouds and precipitation (ages 10-12). The article would have to be simplified by the teacher and probably some details such as fluctuations in acceleration would have to be omitted to keep it simple enough for young students.
- Geography: weather observations, types of clouds, altitude of clouds (ages 10-16+)
- Physics: reflection and radiation of heat, greenhouse effect, climate change (ages 13+)

The article can also serve as an introduction to further activities. Younger students could be involved in observations of clouds, temperature, humidity and the amount of precipitation, after which they could present their results in class. They could also discuss the effect of clouds on climate change and the effect of a polluted atmosphere on precipitation.

The author mentions some specific examples of how clouds affected temperatures and climate in northern China and the southeast Pacific, as well as some current research in this research field. Older students should be motivated to do further research about the relationship between cloud formation and cloud types with climate change.

The large amount of detail also makes this article suitable for comprehension exercises in class. Some suggestions for questions could be:

1. What are clouds made of?
2. How are they formed?
3. How do cloud altitude and cloud seeds impinge on the temperature of Earth's surface?
4. What consequences does this have on climate change?

Catherine Cutajar, Malta

REVIEW

Cotton-puffs, or heaps of cotton-puffs, are *cumulus* clouds. On a cloudy day, the sky is usually covered by flat, hazy and featureless *stratus* clouds. Each cloud can be classified as one or a combination of these types of clouds (see diagram on page 54).

Furthermore, clouds are classified according to their altitude into: low-level (up to 2000 m), medium-level (2000-6000 m), and high-level clouds (over 6000 m). The height of the clouds determines their temperature, which then determines how much

energy they radiate. High-level clouds are cold and radiate little heat into space; instead, they reflect heat radiation back towards Earth's surface, warming the atmosphere and magnifying the greenhouse effect. Low-level clouds, more compact and warmer,

emit more heat radiation into space than back towards Earth. They act as a parasol, reflecting sunlight and thus cooling Earth's surface.

A cloud's altitude, therefore, determines its effect on the climate. By studying the occurrence of high-level and low-level clouds, we can begin to understand the roles they play. If both types of clouds were to occur equally, then the warming and cooling effects would counteract each other, resulting in little heating or cooling of Earth's surface. If the occurrence of high-level clouds increased while that of low-level clouds decreased, there would be a notable increase in atmospheric temperature.

So, why do clouds appear and disappear, and what determines their formation and precipitation?

Image courtesy of NASA

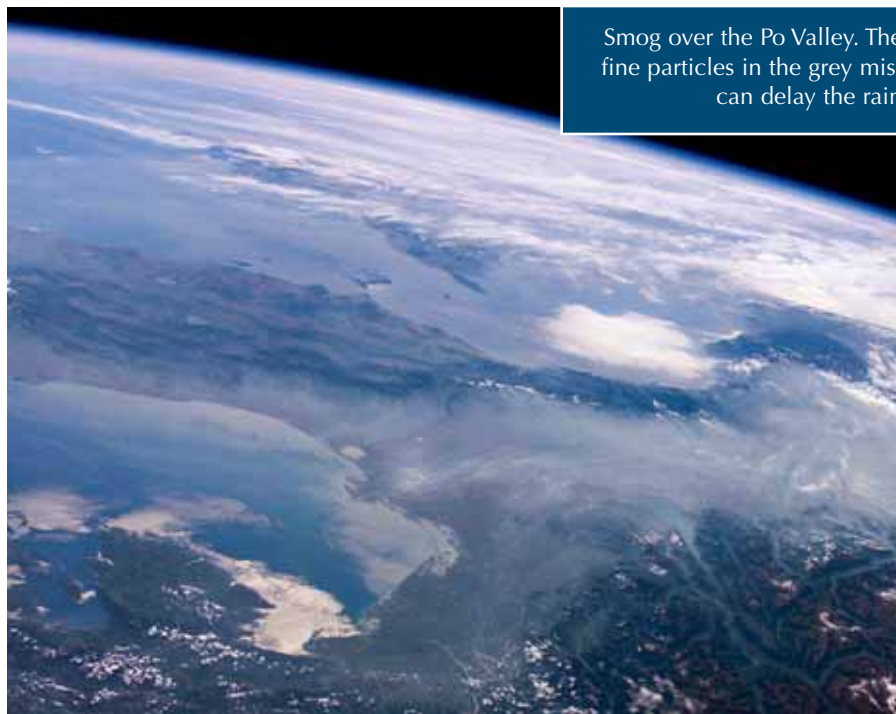

Cloud seeds

All clouds have one thing in common: they form from cloud seeds – also known as aerosols. When water evaporates under the Sun's heat, the vapour rises into the air and the water molecules condense on the aerosols – which can be natural, such as salt, or anthropogenic, such as sulphates. If the cloud seed is at least 60-80 nm in diameter, a water envelope can collect around it, forming a droplet. The cloud consists of many of these droplets. If the droplets reach a

diameter of 0.5-1 mm, they will fall – colliding with other droplets, assimilating them and swelling into raindrops, which can fall at up to 35 km/h.

Aerosols play an important part not only in cloud formation, but also in precipitation: they determine when and where it rains. In a pristine atmosphere with very few particles, sunlight evaporates a great deal of water. As it rises, the vapour finds very few condensation seeds in the

air, so the drops forming around those few seeds are very large, and it rains heavily.

In a polluted atmosphere, the large number of aerosol particles prevents much of the Sun's radiation from reaching the ground, causing less water to evaporate. As the vapour rises, it finds many seeds, creating more, but smaller droplets. This slows down the formation of raindrops (droplets only fall once they reach 0.5-

In a pristine atmosphere (left), large raindrops quickly form and soon rain down. Only a small portion of the cloud droplets rise further, whereupon they freeze and drift away. In a polluted atmosphere (right), the vapour finds many aerosol particles, so it forms only very small cloud droplets that rise to high altitudes and freeze while they are up there. Additional vapour then condenses on the ice crystals. This is how energy-filled thunderclouds form, which bring heavy precipitation

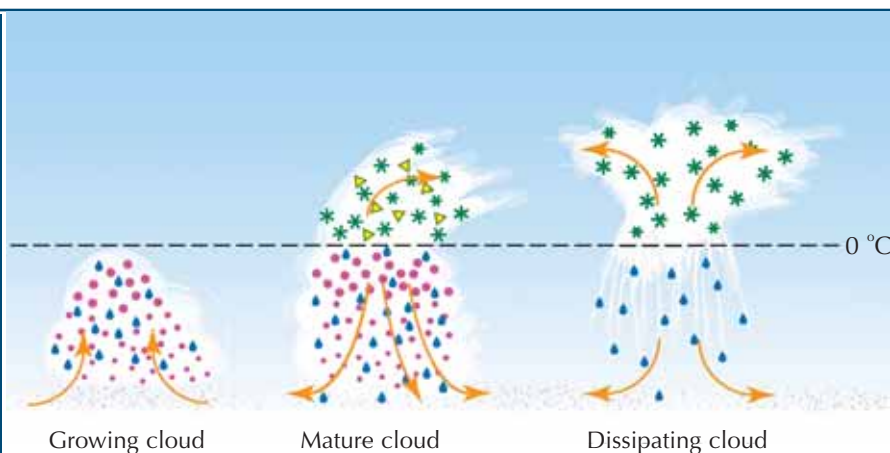

Image courtesy of NASA

Dust storms – like this one over the Red Sea off the coast of Saudi Arabia – are natural sources of aerosols



Fly ash particles as seen under a scanning electron microscope

Image courtesy of the Max Planck Institute for Chemistry, Mainz, Germany

1 mm), so it does not rain on the point of origin. More water condenses on the seeds as the cloud continues to rise and the low temperatures freeze the drops. So the cloud does not rain, but continues to climb higher.

High concentrations of aerosols can inhibit precipitation and even cloud formation entirely. The aerosol concentration in northern China, for example, is thought to be the cause of the major shift in the frequency of

precipitation. On a global scale, of course, all water that evaporates must eventually precipitate. Thus clouds that only rarely empty their contents will do so in the form of heavy rainfall, causing floods, landslides and mudslides.

Puzzling hurly-burly

Although aerosols explain the formation of clouds, and to some extent the occurrence of precipitation, they

do not explain another crucial factor in climate: why do clouds change shape, and why do they appear and disappear?

The shape and lifespan of clouds, and thus their influence on climate, is determined by turbulence. At the edges of a cloud, turbulence mixes the dry surrounding air with the moist cloud air. This is called 'mixing entrainment'. On a microscopic scale, entrainment changes the distribution and size of the cloud droplets, affecting the cloud's tendency to rain or dissipating the cloud completely. But its effect can also be global. For example, if clouds over the frequently cloud-covered southeast Pacific Ocean disperse, there will be more solar radiation, contributing to phenomena like *El Niño*, which is characterised by an increase in the ocean's temperature.

Images courtesy of Roland Wengenmayr

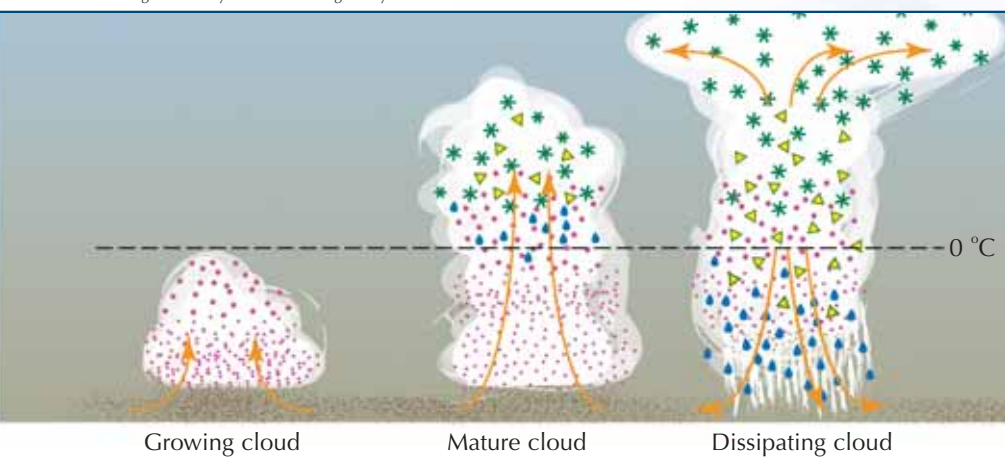

To forecast the fate of a cloud, scientists must know how turbulent the droplets are: this determines how fast the raindrops form and fall. However, studying turbulence in clouds is a complex task due to the different dimensions of clouds' components (a tiny droplet, a larger raindrop, an air current) and the physical processes taking place within and between them.

To understand the effect of turbulence, not only the droplets' velocity and trajectory but also their acceleration is important. Acceleration fluctuates considerably, and can peak at more than 20 times gravity. The frequency of collisions, which increase the chances of precipitation, is determined by particularly strongly accelerated groups of droplets. These strong fluctuations in acceleration could explain why droplets are found to collide more quickly than conventional physics theories allow.

Closing in on clouds

While some scientists try to recreate the conditions of turbulence in clouds using huge wind canals, others study it using computer simulations and fieldwork. For example, Björn Stevens, a researcher at the Max Planck Institute for Meteorology^{w1} in Hamburg, Germany, studies marine *stratocumulus* clouds, which form over cold regions of the subtropics, such as off the Californian and South American Pacific coasts and over the Atlantic coastline near Namibia. They exert a great influence on the global climate, covering more than one tenth of the oceans' area. Stevens found out that these clouds are quite peculiar: satellite images show 'holes' in the solid cloud blanket and although the clouds do not normally cause heavy rain, they do so around the holes. And when these clouds rain, turbulence – the circulation of air between the ocean and the cloud – can change radically.

Stevens and his colleagues are now incorporating their newly gained information on cloud behaviour into the global climate computer models. In these models, the atmosphere is divided into grid boxes; for each box, the computer calculates average values of temperature, humidity and other characteristics of the atmosphere, and predicts cloud formation. Although the models are not yet precise enough to predict the exact locations where the clouds will form, they can now calculate the degree of cloud cover and type of clouds in each grid box, thus allowing the influence on heat and solar radiation on cloud formation to be quantified.

Scientists, therefore, are still investigating the relationship between cloud cover, precipitation, aerosols and the properties of air surrounding clouds – all fundamental for understanding the link between clouds and climate change. So far, they are not even close to deciphering all the different mecha-

Image courtesy of Jacques Desclotres, MODIS Land Rapid Response Team, NASA / GSFC



Marine stratocumuli like these off the coast of southwest Africa reflect the sunlight. Will their number increase as the climate changes?

Image courtesy of David Ausserhofer



Björn Stevens explains which factors influence the structure of tropical rain clouds

nisms involved in the behaviour of clouds and thus, their effect on our climate. But the scientists will not give up, because, as the French Renaissance philosopher and naturalist René Descartes said: “Clouds provide the key to understanding all things wonderful on Earth.”

Acknowledgement

This article was compiled from three articles published in *Max Planck Research*: Meier (2010), Hergersberg (2010) and Wengenmayr (2010). *Max Planck Research* is published by the Max Planck Society and describes – in simple language – the work of its research institutes. The quarterly publication is freely available to download^{w2}.

References

Meier C (2010) Water with a Nebulous Effect. *Max Planck Research* **2.2010**: 17-23

Hergersberg P (2010) Droplets on a Roller Coaster. *Max Planck Research* **2.2010**: 32-37

Russell A, Ricketts H, Knight S (2007) Clouds. *Physics Education* **42(5)**: 457-465. doi: 10.1088/0031-9120/42/5/002

Wengenmayr R (2010) The Seeds of Climate. *Max Planck Research* **2.2010**: 24-31

Web references

w1 – To learn more about the Max Planck Institute for Meteorology, see: www.mpimet.mpg.de

w2 – To download each issue of *Max Planck Research* (available in English and German), visit the website of the Max Planck Society (www.mpg.de) or use the direct link: <http://tinyurl.com/35aunrs>

Resources

To learn more about climate change and its causes, see:

Benestad R (2007) What do we know about climate? The evidence for climate change. *Science in School* **7**: 49-51. <http://scienceinschool.org/2007/issue7/climate>

Benestad R (2008) What do we know about climate? Investigating the effects of anthropogenic global warming. *Science in School* **8**: 48-51. <http://scienceinschool.org/2008/issue8/climate>

For activities related to clouds see:

Bultitude K (2009) Take the weather with you. *Science in School* **11**: 52-57. <http://scienceinschool.org/2009/issue11/weather>

For activities for the classroom about climate change see:

Shallcross D, Harrison T, Henshaw S, Sellou L (2009) Fuelling interest: climate change experiments.

Science in School **11**: 38-43. www.scienceinschool.org/2009/issue11/climate

Shallcross D, Harrison T, Henshaw S, Sellou, L (2009) Looking to the heavens: climate change experiments. *Science in School* **12**: 34-39. <http://scienceinschool.org/2009/issue12/climate>

Shallcross D, Harrison T (2008) Climate change modelling in the classroom. *Science in School* **9**: 28-33. www.scienceinschool.org/2008/issue9/climate

Shallcross D, Harrison T (2008) Practical demonstrations to augment climate change lessons. *Science in School* **10**: 46-50. www.scienceinschool.org/2008/issue10/climate

In this issue, there are two further related articles:

Harrison T, Shallcross D (2010) A hole in the sky. *Science in School* **17**: 46-53. www.scienceinschool.org/2010/issue17/ozone

Schüllli T (2010) Science is cool... supercool. *Science in School* **17**: 17-22. www.scienceinschool.org/2010/issue17/supercooling

To browse all science topic articles in *Science in School*, see: www.scienceinschool.org/scientopics

Karin Ranero Celius obtained a bachelor’s degree in physics and psychology, and then an MSc in museum studies. Her passion for educating others about the wonders of science has led her to become a science communicator. She has been dedicated mainly to outreach and education, first at the Instituto de Astrofísica de Canarias, in Spain, then at the European Southern Observatory in Munich, Germany, and now at the European Molecular Biology Laboratory in Heidelberg, Germany.

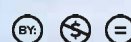

An astronomer in a 3D world

What do astronomy and film have in common? Both can involve Jochen Liske, astronomer and actor. **Karin Ranero Celius** takes us on a trip to the Paranal Observatory in Chile and tells us about Jochen's latest film: *Das Auge 3D*.

Image courtesy of Swinburne Astronomy Productions / ESO

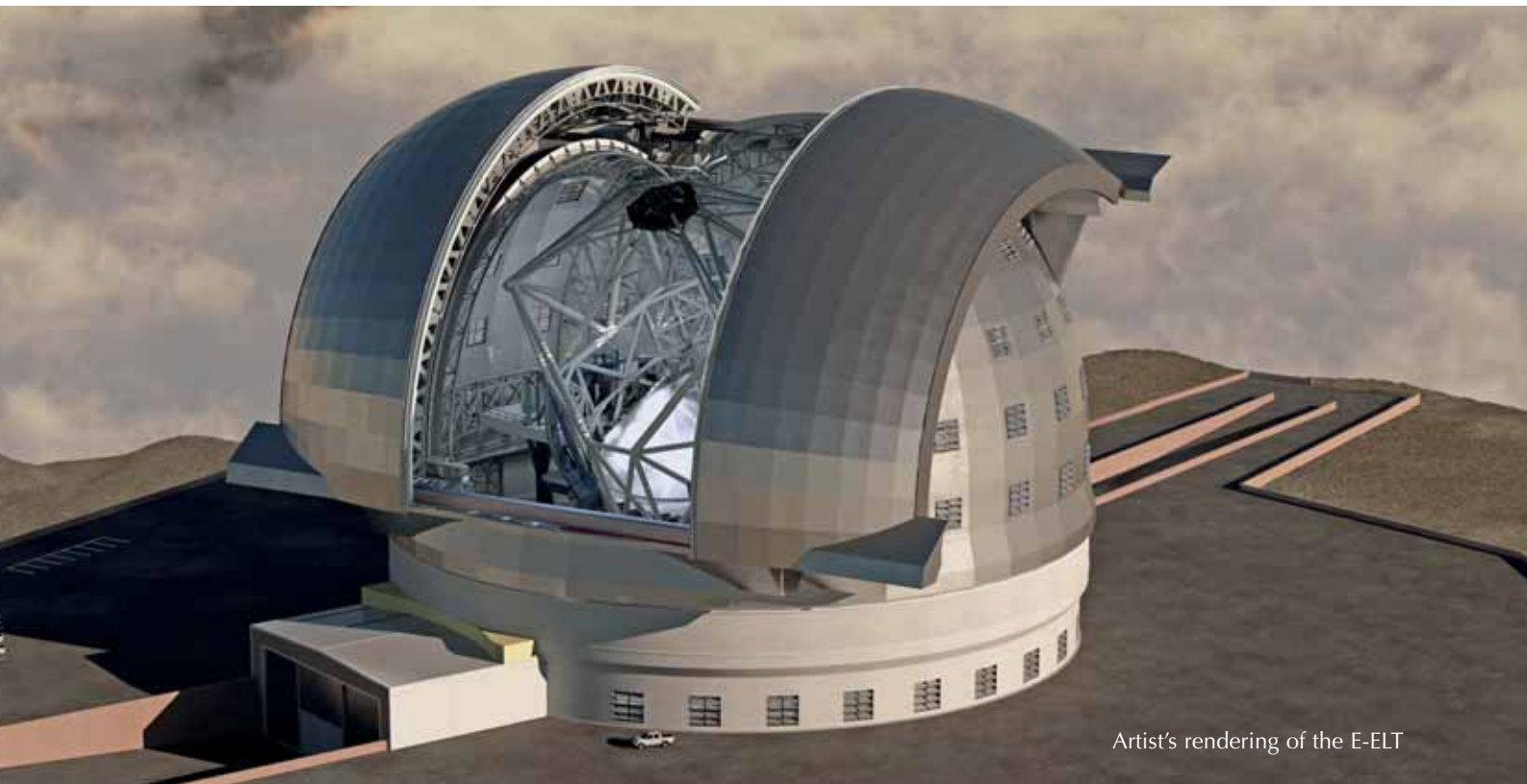

Artist's rendering of the E-ELT

As darkness approaches, a glowing band of light, the Milky Way, extends from one horizon to the other, and stars shimmer over the site where a privileged few are investigating the beginning of the Universe: the Atacama Desert, in Chile.

A curiosity-driven astronomer from the European Southern Observatory (ESO)¹, Jochen Liske, has always had

Image courtesy of Dr Jochen Liske



Dr Jochen Liske

a passion for finding out how the world around us works, and has devoted his life to trying to uncover and explain its nature. "I've always been interested in science. I realised I had a passion for finding out what makes the world tick, when popular science magazines no longer satisfied my curiosity and always left me wanting more."

Aerial view of the ESO Very Large Telescope platform atop Cerro Paranal, in the Chilean Atacama Desert

Image courtesy of JL Dauvergne & G Hüdepohl / ESO

Particularly drawn to the ‘fundamental’ sciences of particle physics and cosmology, Jochen pursued a career in physics, studying at the University of Bonn, Germany, and then gaining a PhD at the University of New South Wales, in Australia. “Astronomy is developing very rapidly, and it is very exciting and inspiring to watch it all happen, and to be a part of it in some small way. As an astronomer, I get to travel to very exotic and remote places, and I have the privilege of ‘playing’ with some pretty amazing equipment and analysing photons that have been zipping across the universe for a few billion years and suddenly crash into ‘my’ telescope.”

Jochen is currently working in the science team of the European Extremely Large Telescope (E-ELT)^{w2}: “I use computer simulations to try and see how far we will get with this telescope in answering certain scientific questions.”

His main research goals, however, will be achieved only once the telescope is completed: “I want to use the E-ELT to observe, in real time, the evolution of the Universe, which occurs over billions of years, by watching it very closely over a time frame of only 20 years. I hope to be

The Paranal Observatory is at one of the driest places on Earth. The water supply is regularly brought in big tanks from Antofagasta, the next city, which is one and a half hours away by car



Image courtesy of ESO

able to literally watch how the speed with which the Universe expands changes. This means that I need to make extremely precise measurements of the speed at which distant objects move away from Earth. A very large ground-based telescope is needed to perform these measurements, so this will only be possible with the E-ELT. This and other experiments carried out with the E-ELT could provide important clues to the nature of the, as yet, unexplained acceleration of the Universe’s expansion, leading to a more fundamental insight into the basic laws that govern nature.”

Image courtesy of Parallax Raumprojektion



The Parallax Raumprojektion crew during filming

Starring in a 3D world

“Being an astronomer implies being a communicator: you end up talking a lot in front of audiences in conferences, schools, and public outreach events, so fear of public speaking is not something you frequently encounter among astronomers.”

Jochen is not only an astronomer and a communicator, but also a talented actor. “I was always part of the theatre group in secondary school and performed in a number of plays. This has helped me in my job and to stand up in front of the camera.” His acting ability has been a key tool for communicating science in a world that is unthinkable without modern science.

As well as being ‘Dr J’, the host of two popular video podcasts, the Hubblecast^{w3} and the ESOcast^{w4}, which bring the latest science from the Hubble Space Telescope and from ESO to a wide audience, Jochen has participated in various astronomy-related documentaries and frequently gives media interviews and public talks. His participation in the E-ELT



Rare 360-degree panorama of the Southern Sky

Image courtesy of ESO / HH Heyer

Image courtesy of ESO / G Lombardi



15 years ago, Cerro Paranal, the site of the VLT, looked like Cerro Ventarrones does today

project, however, has led to his most stellar appearance thus far: in *Das Auge 3D (The Eye 3D)*^{w5}.

Once we don our 3D glasses, the movie theatre merges with the arid landscape, and we are virtually transported to Cerro Paranal, one of the most remote locations on the planet, and the site of one of the best observatories in the world, the Paranal Observatory^{w6}.

According to Nikolai Vialkowsch, director of *Das Auge 3D*, "it is not a movie about science, it's about curios-

ity, and how curiosity led to science, and science led to devices to explore the stars. It is the story of one of these devices: the Very Large Telescope (VLT), its people and the environment of the Paranal Observatory. It is the story of an age-old fascination." Building and operating technological masterpieces such as the VLT requires many years of hard work, money and the efforts of countless individuals – without which the science could not be done.

We accompany Marcelo, a crucial person in the operation of Paranal, on his daily three-hour drive to supply the entire VLT complex with 27 000 litres of water. Without him, the observatory would not function.

Leaving the heat of the desert, we are then taken on a breathtaking tour of the site. One moment we are inside the giant domes, nearly touching the mirrors of the 8.2 m diameter telescopes. Then we are outside on the telescope platform, where one of the Unit Telescopes moves towards us as it is positioned for its next observation. And then we suddenly find ourselves beneath the summit of Cerro Paranal, in the dark blue realm of the Very Large Telescope Interferometer (VLTI)^{w7} delay tunnel: the world of Nicolas Schuhler. He is an engineer who is living his schoolboy dream: to work on the VLTI.

Eventually, we are taken to a deserted area about 30 km from Paranal. Jochen climbs the small tower atop a bare mountain and looks into the desert.



Das Auge 3D: The next best thing to really being at Paranal

BACKGROUND

In June 2009, a crew of German 3D film experts from Parallax Raumprojektion travelled to Chile's Atacama Desert, one of the most arid places on Earth, where ESO's Very Large Telescope is located on Mount Paranal. *Das Auge 3D* is the first 3D documentary produced in Germany. Directed by Nikolai Vialkowitsch, the film, lasting about 45 minutes, transports the viewers to one of the world's greatest observatories. The motion picture was appointed a special project of the International Year of Astronomy^{w8} and has won a special prize for its images at the 2010 Dimension3 film festival^{w9} in Seine-Saint-Denis, France. Although not yet available on DVD, it is currently being shown in

German in cinemas in Germany and Austria. The English version will be released soon. It has been bought by National Geographic and will soon be released worldwide.

Interested schools can contact Stefanie Knoll (email: distribution@raumprojektion.de) to book a German-language screening in collaboration with a 3D cinema nearby. It is also possible to invite the director or one of the astronomers from the film as interview partners. The film website offers a teaching unit on the telescopes, to better integrate the screening in the curriculum, as well as a physics teacher's report on his experiences with watching the film in school^{w5}.

This is Cerro Ventarrones. It was one of the possible sites for the construction of the E-ELT before Cerro Armazones was finally chosen. Jochen tells us "It is just this rickety little five or six metre high tower with a small telescope and a meteorology station, so it's all very rough and desert-like up there. It's quite an achievement to build such high-tech structures like the VLT or the E-ELT out here."

In *Das Auge 3D*, Nikolai and Jochen aim to bring astronomy closer to the public and inspire them to want to know more. Have you ever wondered what the world would be like if humans had not been curious and eager to answer questions? Jochen thinks that "we would still think that Earth is the centre of the Universe, we still wouldn't know why apples fall from trees, and we'd be navigating by

compass alone. Although astronomy won't give us a cure for cancer and it won't provide us with clean, free energy either, I strongly believe that it is worth doing. And communicating."

Acknowledgement

The author would like to thank Parallax Raumprojektion for their cooperation.

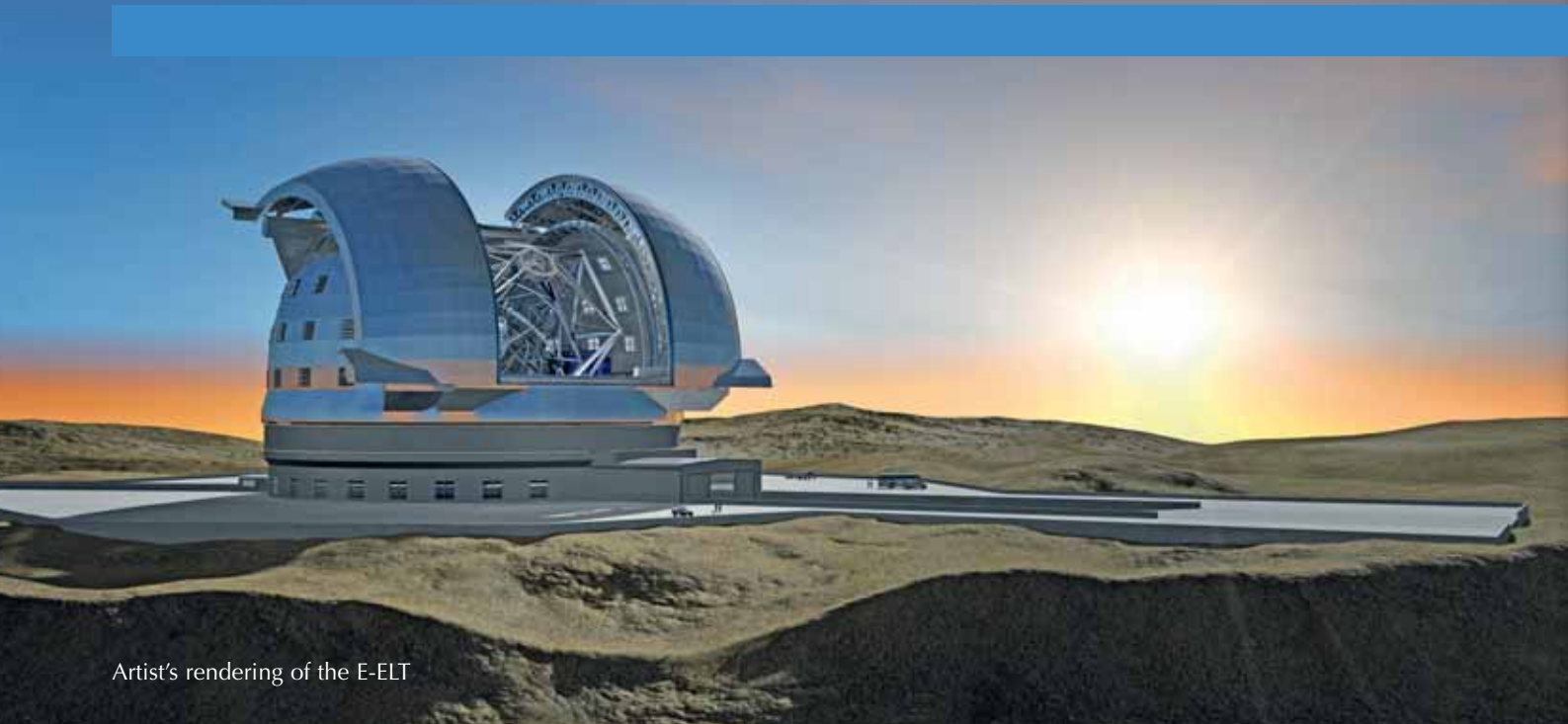

Artist's rendering of the E-ELT

Image courtesy of ESO

Web references

w1 – ESO, the European Southern Observatory, is the foremost inter-governmental astronomy organisation in Europe, and the world's most productive astronomical observatory. See: www.eso.org

w2 – ESO's E-ELT will be 42 m in diameter and will be the world's biggest eye on the sky. For more information see: www.eso.org/public/teles-instr/e-elt.html

w3 – Hubblecast is a scientific and educational videocast about the Hubble telescope, offered for download in several formats: standard (mov, mpeg, mp4, m4v), HD (High Definition) and Full HD. To watch Hubblecasts see:

www.spacetelescope.org/videos/archive/category/hubblecast

w4 – ESOcast is a videocast series dedicated to bringing you the latest news and research from ESO, available in the same formats as the Hubblecast^{w3} except for Full HD. To watch the episodes, see: www.eso.org/public/videos/archive/category/esocast

w5 – For more information on *Das Auge 3D (The eye 3D)*, where it is being screened, and material for schools, see: <http://dasauge3d.wordpress.com>

w6 – Paranal is an ESO-operated astronomical observatory located on Cerro Paranal in Chile, at an altitude of 2635 m. It is home to the Very Large Telescope (VLT), the world's most advanced visible-light astronomical observatory, which consists of four unit telescopes with main mirrors of 8.2-m diameter and four movable 1.8-m diameter auxiliary telescopes. For more information about Paranal visit the ESO website^{w1}. To learn more about the VLT, see:

Pierce-Price D (2006) Running one of the world's largest telescopes. *Science in School* 1: 56-60. www.scienceinschool.org/2006/issue1/telescope

w7 – The Very Large Telescope Interferometer (VLTI) combines two or three of the VLT telescopes, allowing astronomers to see details up to 25 times finer than with the individual telescopes. To learn more about the VLT and interferometry, search the ESO website (www.eso.org) or use the direct links <http://tinyurl.com/35we9qg> and <http://tinyurl.com/38ov7s4>

w8 – For a collection of education resources surrounding the International Year of Astronomy, see: Starr C, Harwood C (2009)

Education resources for the International Year of Astronomy. *Science in School* 13.

www.scienceinschool.org/2009/issue13/iya

w9 – To find more information on the Dimension3 film festival, see: www.dimension3-expo.com/uk/festival.php

Resources

To browse all *Science in School* articles about ESO, see: www.scienceinschool.org/eso

Karin Ranero Celius obtained a bachelor's degree in physics and psychology, and then an MSc in museum studies. Her passion for educating others about the wonders of science has led her to become a science communicator. She has been dedicated mainly to outreach and education, first at the Instituto de Astrofísica de Canarias, in Spain, then at the European Southern Observatory in Munich, Germany, and now at the European Molecular Biology Laboratory in Heidelberg, Germany.



Publisher: EIROforum,
www.eiroforum.org

Editor-in-chief: Dr Eleanor Hayes,
European Molecular Biology
Laboratory, Germany

Editor: Dr Marlene Rau,
European Molecular Biology
Laboratory, Germany

Editorial board:

Dr Giovanna Cicognani, Institut
Laue Langevin, France

Dr Dominique Cornuéjols,
European Synchrotron Radiation
Facility, France

Elke Delvoye, European Space
Agency, the Netherlands

Russ Hodge, Max Delbrück
Zentrum, Germany

Dr Rolf Landua, European
Organization for Nuclear
Research (CERN), Switzerland

Dr Dean Madden, National Centre
for Biotechnology Education,
University of Reading, UK

Dr Douglas Pierce-Price, European
Southern Observatory, Germany

Lena Raditsch, European
Molecular Biology Laboratory,
Germany

Dr Fernand Wagner, European
Association for Astronomy
Education, Luxembourg

Chris Warrick, European Fusion
Development Agreement, UK

Copy editor: Dr Caroline Hadley

Composition: Nicola Graf,
Email: nicolagraf@t-online.de

Printers: ColorDruckLeimen,
Germany
www.colordruck.com

Webmaster: Alexander Kubias
Email: mail@alexander-kubias.net

ISSN:
Print version: 1818-0353
Online version: 1818-0361

Cover images:

Images courtesy of Chepko and
Xacto / iStockphoto

www.scienceinschool.org

Safety note

For all of the activities published in *Science in School*, we have tried to check that all recognised hazards have been identified and that suitable precautions are suggested. Users should be aware, however, that errors and omissions can be made, and safety standards vary across Europe and even within individual countries. Therefore, before undertaking any activity, users should always carry out their own risk assessment. In particular, any local rules issued by employers or education authorities MUST be obeyed, whatever is suggested in the *Science in School* articles. Unless the context dictates otherwise, it is assumed that:

- Practical work is carried out in a properly equipped and maintained science laboratory
- Any electrical equipment is properly maintained
- Care is taken with normal laboratory operations such as heating
- Good laboratory practice is observed when chemicals or living organisms are used
- Eye protection is worn whenever there is any recognised risk to the eyes
- Pupils and / or students are taught safe techniques for activities such as handling living organisms, hazardous materials and equipment.

Credits

Science in School is published by EIROforum (a collaboration between seven European inter-governmental scientific research organisations: www.eiroforum.org) and is based at the European Molecular Biology Laboratory (EMBL: www.embl.org) in Heidelberg, Germany.

Science in School is a non-profit activity. Initially supported by the European Commission, it is now funded by EIROforum.

Disclaimer

Views and opinions expressed by authors and advertisers are not necessarily those of the editors or publisher.

We are grateful to all those who volunteer to translate articles for the *Science in School* website (see the guidelines on our

website). We are, however, unable to check the individual translations and cannot accept responsibility for their accuracy.

Copyright

With very few exceptions, articles in *Science in School* are published under Creative Commons copyright licences that allow the text to be reused non-commercially. Note that the copyright agreements refer to the text of the articles and not to the images. You may republish the text according to the following licences, but you may not reproduce the image without the consent of the copyright holder. Most *Science in School* articles carry one of two copyright licences:

1) Attribution Non-commercial Share Alike (by-nc-sa):



This license lets others remix, tweak, and build upon the author's work non-commercially, as long as they credit the author and license their new creations under the identical terms. Others can download and redistribute the author's work, but they can also translate, make remixes, and produce new articles based on the work. All new work based on the author's work will carry the same license, so any derivatives will also be non-commercial in nature. Furthermore, the author of any derivative work may not imply that the derivative work is endorsed or approved by the author of the original work or by *Science in School*.

2) Attribution Non-commercial No Derivatives (by-nc-nd)



This license is often called the 'free advertising' license because it allows others to download the author's works and share them with others as long as they mention and link back to the author, but they can't change them in any way or use them commercially.

For further details, see:
<http://creativecommons.org>

All articles in *Science in School* carry the relevant copyright logos or other copyright notice.

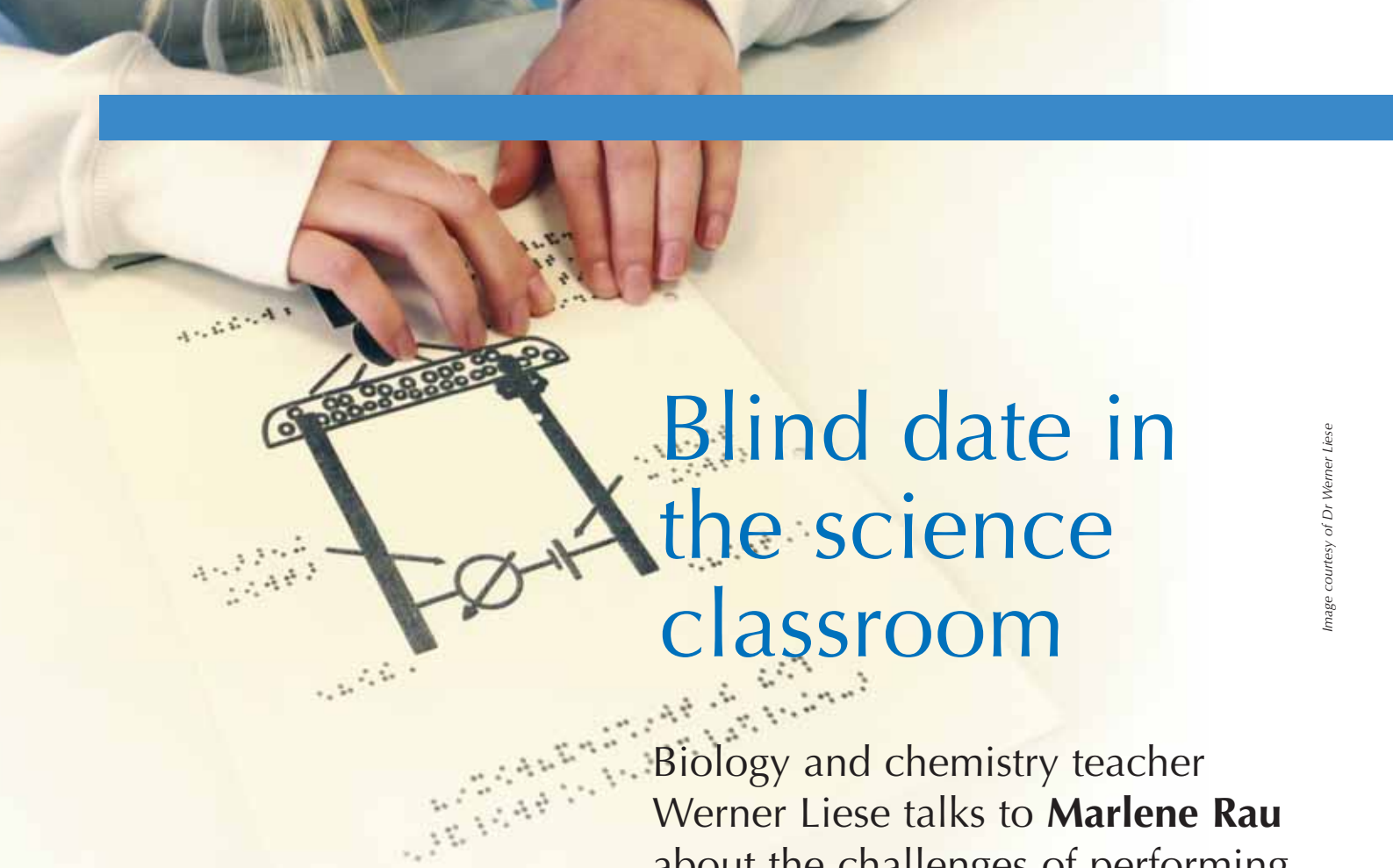

Blind date in the science classroom

Image courtesy of Dr Werner Liese

Biology and chemistry teacher Werner Liese talks to **Marlene Rau** about the challenges of performing science experiments with blind and visually impaired students.

Swelling paper is a special kind of paper which swells up when combined with ink and heat, for 3D representations of diagrams, such as this set-up for the fused-salt electrolysis of sodium hydroxide

Image courtesy of Dr Werner Liese

Werner Liese is no ordinary teacher – and his students aren't ordinary either. The day a friend invited him to sit in on a chemistry lesson he was teaching at the Carl-Strehl-Schule^{w1} in Marburg, Germany, changed Werner's life. He realised that with his hobby – fiddling with electronics – he could make a real difference here. Werner had just finished his training as a secondary-school biology and chemistry teacher and gained a PhD in inorganic chemistry at Marburg University, so he went straight to the school's headmaster and asked for a job: he wanted to apply his skills to using and developing tools for blind and visually impaired students, to help them do experimental work in the science classroom.

Werner got the job, and over the past 29 years has been very successful as both a teacher and technical devel-



A blind student uses a Braille terminal to check the text she has just typed on her laptop. A Braille terminal is actually more expensive than the laptop itself

oper, and has brightened up numerous students' lives.

"It is so important that the students can do their own experiments. This not only helps them to understand

the way scientists work – it is the only viable way to make even complex topics transparent for the students – otherwise they remain just theories. It makes all the difference."

Today, the Carl-Strehl-Schule accommodates more technology than your average school: students take notes mostly on laptops; visually impaired students use digital enlargers to magnify the text they are reading; and blind students can scan in text, after which it is either read aloud to them by a computer or represented on a Braille terminal – an electro-mechanical device for displaying one line of Braille characters at a time by raising pins on a flat surface.

When Werner started his job, things were very difficult. There was not a lot of technological support for his students, let alone for the science classroom. Many experiments had to be explained and the students had no opportunity to experience them first-hand. Shortly after he joined the school, Werner started developing electronic tools for teaching science to

the blind and visually impaired. A full-time electronics engineer was employed to help, and a dedicated workshop was fitted for the task. “Not one teaching-materials supplier worldwide offers ready-made materials adapted for blind students – the market is just too small,” Werner states sadly. “I was very lucky that, for a time, the school relieved me of the majority of my teaching duties so that I could dedicate my time to developing these tools. This, and several generous grants made it all possible.”

What special needs do his students have? “Of course it wouldn’t make sense to concentrate for weeks on end on the chemistry of coloured pigments in a classroom full of blind students. But basically, you can teach any science topic at our school, just as you can at any other. For grades 5 to 10,

Image courtesy of Sonja Dörrich-Liese



Werner Liese in the electronics lab at the Carl-Strehl-Schule, developing the interface for the talking digital burette



The Carl-Strehl-Schule

The Carl-Strehl-Schule is the only school for blind and visually impaired students in German-speaking countries that provides secondary-school education beginning as early as grade 5 (aged 11). To cover such a large geographic area, it needs to be a boarding school. It is part of the German Institute for the Blind (Deutsche Blindenstudienanstalt)^{w4} which also offers training programmes for blind adults, a library of Braille and audio books, and a publishing house for Braille books.

The institute was founded in 1916 to cater for the many young men who had lost their eyesight in World War I. Today, the school’s 300 students, who are taught in small groups of eight to twelve students, arrive at various ages and for different reasons – some have been born blind or visually impaired, others lose their eyesight gradually due to a disease, while others have had an accident.

The Carl-Strehl-Schule has a range of secondary-school branches. After grade 10 (at the age of 16), students can choose three years of general education leading to the

Abitur, which qualifies them to study any subject at university. For these students, the school offers an optional detailed course in economics. Alternatively, students who want to study sociology or economics at a technical university (*Fachhochschule*) can spend two or three years focusing on these subjects.

In addition, the school offers two-year full-time vocational courses to prepare their students for a range of jobs in IT or as foreign-language secretaries.

The Carl-Strehl-Schule also offers advice and practical help for blind and visually impaired students at other schools.

Outside the classroom, students can choose from a variety of extracurricular activities, such as acting, a choir, a rock band, horse-riding, football, judo, swimming, athletics, gardening, excursions to watch and listen to bats, or participation in the environmental club which has installed solar and cogeneration power plants in the school.

BACKGROUND

Image courtesy of Dr Werner Liese



A visually impaired student performs an acid-base titration experiment with the talking digital burette, using the large LCD display

Image courtesy of Dr Werner Liese



The optophone is used to identify the colour change in an acid-base reaction with bromothymol blue indicator. A strong light is shone through the solution, and the optophone sensor (held by the blind girl on the left) measures the incoming light. As long as the solution is yellow (acidic) and the incoming light is strong, the optophone emits a high-pitched sound. When the solution becomes basic and turns blue, optophone will emit a low-pitched sound. The instrument can also be used to measure electrical conductance, emitting differently pitched sounds for different conductivity values

we have adapted the curricula to our students' needs, but from grade 11 onward, they need to prepare for the general school-leaving certificate (*Abitur*), which enables them to go to university. The exam questions are the same for all students in the federal state, so our students need to learn the same material as their peers. We actually collaborate with other secondary schools in Marburg to offer joint courses for sighted and visually impaired students in subjects for which there are very few students.

"The main task for the teacher is to translate visual impressions into impressions our students can perceive with their other senses – mostly acoustic or tactile. Similar tools are employed in all sciences, but chemistry requires the most complex adaptations. For our visually impaired students, we use cameras with special optics to transmit details of the experiments to computer screens. With this the students are able to zoom in sufficiently to easily follow experiments being demonstrated by the teacher or other students. In our media centre and electronics lab, we design instruments that convert light or colours into sound or synthetic speech: students weigh out chemicals with special precision tools, and we fit standard measuring instruments with large digital displays and voice output.

"I had to learn a lot about analogue and digital electronics as well as computer-aided design to be able to tackle more complex projects, such as a digital burette which for the first time enables blind people to perform precise titrations. We fitted a standard burette with an electronic interface that sends the data to an adapter we built, which has a voice output and a very large display. Coupling the burette to a data-recording programme allows the students to produce not only tables but also graphical representations of the data. These can then be made available in tactile form by printing them onto 'swelling paper', a special kind of paper that swells up when combined with ink and heat.

"Many of the tools we have produced in our workshop are not available anywhere else. However, two of the instruments that we developed are also commercially available: a talking digital multimeter, and an 'optophone' – an instrument to measure light intensity and electrical conductance and translate this into sounds at different pitch."

Another project Werner is particularly proud of is the LiTeX programme^{W2}, which he has been working on over the past nine years; it is now the most comprehensive German-language writing tool for the blind and visually impaired. "It is a freely downloadable template for Microsoft Word™ which enables the simple integration of formulae, equations, structural formulae and Lewis notation for maths, physics and chemistry, and offers a number of important help functions for writing normal texts which weren't available before. Even many sighted people find it useful."

Werner is also active outside the school walls. When his former PhD supervisor founded the Chemikum^{w3} teaching lab at Marburg University, Werner was called in to develop experiments and adaptations to enable blind and visually impaired people to use the lab. This experimental chemistry lab is open for anyone aged four and above – school classes, groups or individuals – to attend demonstrations or take part in hands-on experiments.

This project fulfils Werner's ambitions for science education: "Anyone can enjoy science. But it is extremely important for teachers to be creative in their use of equipment. This is true not only at a school like ours, but in any classroom. Besides, he or she has to be enthusiastic and transmit this enthusiasm to the students." Werner's students demonstrate his success – one of his former students, a blind boy, has graduated in biology at Marburg University, while another visually impaired student has successfully completed a PhD in chemistry. Werner has achieved his goal: he has made science more accessible to everyone – including the blind.

Web references

w1 – Find out more about the Carl-Strehl-Schule on the school's website (in German): www.blista.de/css

w2 – The LiTeX programme is freely available on Werner Liese's website, which also contains more information about Werner and his work (in German): www.werner-liese.de

w3 – The Chemikum Marburg offers anyone aged four and above the possibility to do chemistry experiments (in German). See: www.chemikum-marburg.de

w4 – Learn more about the German Institute for the Blind (*Deutsche Blindenstudienanstalt*) here (in German): www.blista.de

Resources

To browse all teacher profiles in *Science in School*, see: www.scienceinschool.org/teachers

Dr Marlene Rau was born in Germany and grew up in Spain. After obtaining a PhD in developmental biology at the European Molecular Biology Laboratory in Heidelberg, Germany, she studied journalism and went into science communication. Since 2008, she has been one of the editors of *Science in School*.

Marlene's father has been blind since he had an accident at the age of 20, and she has lived in Marburg for much of her life – going to school and university with



Image courtesy of Dr Werner Liese

In the chemistry classroom, students at the Carl-Strehl-Schule use magnetic boards for Lewis notation and studying chemical reactions, such as the reaction of sodium with water



Image courtesy of Conny Peil, Carl-Strehl-Schule

Reaction of sulphuric acid with sodium chloride in a miniature apparatus. The modular design of this system enables blind and visually impaired students to set up the experiment more easily, while the smaller amounts of chemicals used reduce experimental hazards. The small size of the set-up allows the camera to capture the whole set-up in one image, and small vials reduce disruptive reflections. The cameras show two different magnifications of the experiment

blind people, meeting them on the street every day, going horse-riding with them, teaching them Latin, sharing a house with a blind friend and living opposite the Carl-Strehl-Schule for a couple of years. Blind people have always been an integral part of her life – and she finds that their lives are not so very different, really.



Very Short Introductions to Evolution, Human Evolution and the History of Life

By Brian and Deborah Charlesworth (*Evolution*), Bernard Wood (*Human Evolution*) and Michael J Benton (*The History of Life*)

Reviewed by Colin Johnson, UK

How short is 'very short'? Well, pretty short – between 120 and 150 pages. The pages are small, too, 175 mm x 110 mm, but then so is the type. 'Introduction?' ...well, it depends what's being introduced. These are cleverly written books, compressing a great deal of material and a reasonable number of black and white illustrations into a small space. It would be a mistake to confuse brevity with accessibility, however. So – from the point of view of a school-teacher considering purchases – what are we looking at here?

Evolution: A Very Short Introduction follows a path you would expect: the evolutionary processes, evidence for evolution, adaptation and natural selection, and the formation and divergence of species. Had the book been written today, the word 'creationism' would surely have been in the index, but the final chapter does not shirk what the authors have called "difficult problems" – complex adaptations, ageing, the evolution of sterile social castes, and the origin of living cells and of human consciousness. This is tough going – a solid

read for an advanced teacher, but unlikely to engage many school students. It's a book for the teacher's shelf – perhaps to be dipped into as a refreshing summary of a key topic: the 'evidence for evolution' chapter would be a good brief source of reference.

Human Evolution: A Very Short Introduction is by 'a medically qualified palaeo-anthropologist' – and it shows. It deals with the fossil record, early hominins, transitional hominins and early *Homo* before turning to the people who inhabit the globe today. There's a chronology "of thought and science relevant to human origins and evolution", which – though brief – is seriously academic. Individual sections of this book contain engaging narratives, and thorough explanations, but the sheer density of the writing must take it beyond school science and well into specialist reading at university level. Teachers will find the 'points to watch' sections at the end of each chapter very valuable, however. They provide caveats for teaching and some really good starting points for discussion and wider reading.

The History of Life: A Very Short Introduction would appear to have the toughest task of all: the origins of life, sex, skeletons, life on land, forests and flight, the biggest mass extinction, the origin of modern ecosystems and the origins of humans. Happily, however, the author manages to cover all this ground deftly – almost conversationally – and with considerable clarity. Of course, the depth of detail isn't there and a few academic noses may be turned up at the lively personal style, but this book communicates with the non-specialist reader in a way that the others struggle to achieve. It is indeed an 'introduction', and many a school student will enjoy reading it. Try leaving it lying around in your lab for someone to pick up, or – in more traditional mode – make sure that it is on your students' reading list.

Details

Evolution: A Very Short Introduction

Publisher: Oxford University Press

Publication year: 2003

ISBN: 9780192802514

A Private Universe

online resources

By Dr Matthew H Schneps and Dr Philip M Sadler
Reviewed by Erik Stengler, Spain

Human Evolution: A Very Short

Introduction

Publisher: Oxford University Press
Publication year: 2005
ISBN: 9780192803603

The History of Life: A Very Short

Introduction

Publisher: Oxford University Press
Publication year: 2008
ISBN: 9780199226320

Resources

For a review of two other *Very Short Introductions*, see:

Demoncheaux E (2007) Review of *Fossils: A Very Short Introduction* and *Dinosaurs: A Very Short Introduction*. *Science in School* 6: 85. www.scienceinschool.org/2007/issue6/fossils

To browse all the other reviews of resources published in *Science in School*, see: www.scienceinschool.org/reviews



A *Private Universe* depicts a very familiar situation for teachers worldwide, namely that students do not let go of their misconceptions as easily as might be expected after a detailed and thorough learning process.

This series started with an award-winning short documentary feature in 1987. Even 23 years after its production, a collaboration between the Harvard-Smithsonian Center for Astrophysics^{w1} and Annenberg Media^{w2} (then Annenberg / CPB), it has not lost its relevance. This first part focuses on the astronomical topic of the seasons, particularly on the fact that despite years of education in physical sciences and astronomy, even Harvard graduates still think that it is hotter in summer because the Sun is nearer to the Earth than in winter. The film also mentions another aspect in which misconceptions prevail over formal teaching: the phases of the moon, which are often wrongly explained in terms of obscuration by clouds, rather than by the relative positions of the Sun, Moon and Earth.

This situation is indeed quite widespread, and it is not uncommon to hear complaints by teachers and professors about it. It becomes even more alarming when it is the teachers themselves who pass on these misconceptions to their students. This is

often the case in countries where primary-school teachers are not taught any content related to the topics they will be teaching at school. Instead, the focus lies on educational issues, assuming the candidates still know the topics they will teach well enough from their own days at school. The reality is quite different, as is clearly seen in the first minutes of *A Private Universe*.

But *A Private Universe* does not stop at detecting the problem. In order to diagnose its scope and possible causes, the documentary closely follows the learning process of a particular high-school student, considered to be one of the brightest of her class. Her teacher makes quite an effort to explain how Earth orbits around the Sun, and how the seasons are produced by a combination of this and the 23.5° tilt of Earth's axis of rotation. Viewers will be as surprised as the teacher herself when the student, after having shown clear signs of understanding, still tries to save and include her previous misconceptions into her new and even elaborate view on the matter.

Particular misconceptions can be traced back to confusing or ambiguous graphics in a school book, but to lay the blame solely on these accessory aspects would be to completely miss the point, and is definitely not

sufficient to explain the widespread endurance of these misconceptions throughout the educational system.

A Private Universe does not come up with a magical solution. It is however a valuable resource to help teachers become aware of the power of the misconceptions that students bring with them into the classroom. The documentary can be watched freely online^{w3} and is the start of a series of videos and resources produced by this collaboration, which can all be accessed freely online. DVDs and VHS cassettes of the videos are also available for purchase, but only within the USA.

The follow-up series, entitled *Minds Of Our Own*^{w4}, explores further misconceptions and strategies to avoid them. In the *A Private Universe* teacher's lab^{w5}, a web resource built around the misconceptions on astronomy facts that are highlighted in the first documentary, you can test your own knowledge and misconceptions, comparing them with the most popular answers given so far, or print out a survey for your students. It contains a discussion forum on how misconceptions arise, and a small collection of teaching activities to avoid the most misconceptions about the Sun, Moon and Earth.

The *A Private Universe project in science*^{w6} is a collection of nine workshop videos, of 90 minutes each, focusing on one theme and content area of science – from biology, chemistry or physics – and using specific examples to show how students' preconceived ideas can create critical barriers to learning. Education experts also review classroom strategies and results and recommend new ways to involve students and approach difficult topics. Short summaries are available online as support materials^{w7}.

A similar workshop series (*A Private Universe project in mathematics*)^{w8} with an accompanying online teacher's lab^{w9} is available for mathematics.

These resources are an invaluable tool not only for primary- and secondary-school teachers of science or mathematics, but also for anyone involved in teacher preparation.

Web references

- w1 – Find out more about the Harvard-Smithsonian Center for Astrophysics here:
www.cfa.harvard.edu
- w2 – Learn more about Annenberg Media and browse the resources and workshops they offer to teachers here: www.learner.org
- w3 – To watch *A Private Universe* online, see:
www.learner.org/resources/series28.html
- w4 – To watch *Minds of Our Own* online, see:
www.learner.org/resources/series26.html
- w5 – Access the *A Private Universe* online teacher's lab here:
www.learner.org/teacherslab/pup
- w6 – To watch the *A Private Universe project in science* workshop videos, see: www.learner.org/resources/series29.html
- w7 – The support materials to the *A Private Universe project in science* can be found here:
www.learner.org/catalog/extras/puptwsup.html
- w8 – To watch the *A Private Universe project in mathematics* videos, see:
www.learner.org/resources/series120.html
- w9 – The *Patterns in Mathematics* teacher's lab can be found here:
www.learner.org/teacherslab/math/patterns

Resources

To browse all the other reviews of resources published in *Science in School*, see:
www.scienceinschool.org/reviews



Educational resources for the International Year of Biodiversity

The United Nations has declared 2010 the International Year of Biodiversity (IYB). **Ivo Grigorov, Lise Cronne and Giulia Realdon** provide a collection of web resources for teachers and students on the occasion.

Images courtesy of Alejandro Morellón



The aim of the IYB is to raise awareness of the accelerated rate of species extinction, caused primarily by human impact on our environment. The resources below offer teachers and students participation in long-term projects, background reading, a wealth of suggested teaching activities, multimedia galleries and much more, aiming to put biodiversity in the context of earth sciences as well as climate change and human impact.

The list is far from exhaustive, so if you have come across other structured and engaging resources that have captured your students' attention and that help put biodiversity into context, please add your comments on our website¹.

Unless stated otherwise, all resources are in English.

The official IYB website

The official website of the IYB, run by the United Nations Environment Programme, provides a variety of multimedia resources and external links covering biodiversity basics, news and initiatives: www.unep.org/iyb

Teacher resources

Teaching Issues and Experiments in Ecology

In this open-access, peer-reviewed journal, university professors provide and report on the efficacy of a variety of ecological educational activities for undergraduates. Some of the information may be useful for secondary-school teachers, too. The 'Teaching resources' section offers general information on teaching ecology and getting the most out of the journal:

<http://tiee.ecoed.net/teach/teach.html>

Nature collection of biodiversity articles

In honour of the IYB, the research journal *Nature* offers a collection of previously published articles addressing the ecological and economic importance of biodiversity. The articles, some of which are freely available, vary in their technicality; teachers or particularly interested students wishing to deepen their understanding of the subject would benefit most from the materials:
www.nature.com/nature/supplements/collections/biodiversity

Science literacy guides

Funded by the US National Science Foundation, the National Marine Educators Association and the National Oceanic and Atmospheric Administration, these literacy guides are developed by scientists for non-experts and educators (primary and secondary school). The guides are constructed around the current science syllabus and extensively address the relationships between biodiversity, the geosphere, the hydrosphere, climate change and human impact.

Earth science literacy: www.earthscienceliteracy.org

Climate literacy: www.climateliteracynow.org

Ocean literacy: <http://oceanliteracy.wp.coexploration.org>

Image courtesy of Alejandro Morellón



Classroom resources

ARKive

ARKive gathers films and photographs of organisms from around the world, focusing on endangered species and ecosystems. The 'Learning resources' section provides teachers with ready-made PowerPoint® presentations, handouts and links to relevant ARKive images for the primary- and secondary-school classroom activities built around Darwin's voyage on HMS *Beagle* and his theory of evolution: www.arkive.org/education/resources

Breathing Places

Aimed at schools and communities supporting younger students, the BBC's Breathing Places project encourages biodiversity awareness and education by suggesting a variety of low-cost outdoor activities to help wildlife. Multimedia guides can be downloaded for free, and a small selection of specific classroom resources are offered. The website is available in English and Welsh:
www.bbc.co.uk/breathingplaces/schools

KeyToNature

KeyToNature supports biodiversity education by providing European schools and universities with interactive software and online tools for identification of organisms. Project partners from 11 countries (Austria, Belgium, Bulgaria, Estonia, Germany, Italy, Netherlands, Romania, Slovenia, Spain, UK) offer materials in 10 languages for a variety of platforms, including Apple®, Windows® and mobile phone, but some require the user to register with the website and / or purchase online access, CD-ROMs or DVDs: www.keytonature.eu/wiki

The BEAGLE project

Students in a class that has registered with the free, online EU-funded BEAGLE project choose a tree in their area and monitor it for a year, contributing to research while learning about biodiversity. Seven hundred and sixty classes from more than 370 schools in 14 European countries are registered on the website, where they enter data, submit photos and compare their results. The website is available in English, German, Hungarian, Norwegian, Polish and Slovene: www.beagleproject.org

Norwegian Environmental Education Network

This website hosts several projects (like the BEAGLE project described above) to which students can contribute local data while learning about sustainable development. More than 2500 participants from 85 countries are already registered. It is available in English and Norwegian:
<http://sustain.no>

Young Reporters for the Environment

Young Reporters for the Environment is an international platform for secondary-school students to research and report on local environmental issues, encouraging them to connect with the public and other young environmental journalists. To celebrate the IYB, they are putting a particular emphasis on the topic:
www.youngreporters.org

Resources for both teachers and students

Virtual expeditions with the Chicago Field Museum

Anyone can follow scientists from the Chicago Field Museum of Natural History, USA, on their current and past expeditions around the world through video reports, interactive online activities, photos, live webcasts and an email list to receive updates directly from the researchers. The expeditions focus on ecology, conservation and archaeology:
www.fieldmuseum.org/expeditions

Tree of Life web project

This collaborative project between experts and enthusiasts seeks to create a complete database of all living organisms, with articles and activities focusing on evolution and biodiversity. Resources for teachers wishing to incorporate ToL activities in the classroom can be found in the 'Learning' section, and they and their students are invited to contribute: www.tolweb.org/tree

Encyclopedia of life

Similar to the Tree of Life web project (with which it has a partnership), EoL aims to create a webpage for each of the 1.9 million species currently thought to exist. EoL provides resources for classroom activities and invites teachers to encourage their students to contribute to the Encyclopedia's vast organism inventory. The website is available in English, French, German, Russian, Spanish and Ukrainian: www.eol.org. The 'Learning and education' pages can be found at:
<http://education.eol.org>

The International Union for Conservation of Nature

IUCN considers conservation of biodiversity to be fundamental in addressing global issues that, ultimately, affect human wellbeing. The biodiversity section of IUCN's website does not provide specific educational resources, but is a thorough source of information on why biodiversity matters and what kinds of projects have been undertaken to preserve it. It is available in English, French and Spanish:
www.iucn.org/what/tpas/biodiversity



The Complete Work of C Darwin Online

The title is self-explanatory; this website freely provides tens of thousands of pages of searchable text and images, including Darwin's original handwritten manuscripts, notes and data. The texts are available in 12 languages (use the search functions for manuscripts and publications to find them), and some are available in downloadable audio format (English only): www.darwin-online.org.uk

Smithsonian National Museum of Natural History

The 'Education' section of this museum, based in Washington DC, USA, provides lesson plans and web-based activities on several topics related to the museum's exhibitions, many of which do not require visits to the institution. Topics include biodiversity, anthropology and ecology, though most activities focus on North American ecosystems: www.mnh.si.edu

Marine Bio Conservation Society

The Marine Bio Conservation Society from California, USA, provides an extensive multimedia collection featuring ocean biodiversity. Forums and educational resources invite students to interact with scientists and conservation organisations, to volunteer, or even to pursue degrees and careers in marine science: <http://marinebio.org>

OceanLink – All about the ocean

Like the Marine Bio Conservation Site, the Canadian OceanLink website provides a wealth of information on ocean life. However, OceanLink also features a 'For teachers' page that links to free, comprehensive PDF guides on classroom activities exploring many aspects of marine science: www.oceanlink.info

Web reference

w1 - To add your own suggestions for further biodiversity-related resources, use the comment function at the bottom of this article's HTML version. See: www.scienceinschool.org/2010/issue17/web

Further resources

If you found this article helpful, you may like to read the other 'Resources on the web' articles published in *Science in School*. See: www.scienceinschool.org/web

Ivo Grigorov is an oceanographer who manages EU research programmes for CNRS, France. He has participated in numerous marine science outreach activities (www.eur-oceans.info) and is the author of a Bulgarian blog on popular science (www.sinia-planeta.com).

Lise Cronne is a geographer working as an outreach officer for the EU research programmes EuroSITES (www.eurosites.info) and SESAME (www.sesame-ip.eu) on global climate change and the marine environment. For the past three years, she has also organised the 'Researchers' night' events in Brest, France, funded by the European Commission.

Giulia Realdon has been a secondary-school teacher of biology, chemistry and earth sciences for 34 years. She holds a degree in biology and a master's in science communication from Padua University, Italy. She is also a teacher trainer and the author of science teaching materials.



How many schools and teachers do you reach – worldwide?



Advertising in *Science in School*



- Choose between advertising in the quarterly print journal or on our website.
- Website: reach 30 000 science educators worldwide – every month.
- In print: target up to 15 000 European science educators every quarter, including 3000 named subscribers.
- Distribute your flyers, brochures, CD-ROMs or other materials either to 3000 named subscribers or to all recipients of the print copies.

For more details, see www.scienceinschool.org/advertising

Published by
EIROforum:



EMBL



esa



Initially supported by
the European Union:



ISSN: 1818-0353

Subscribe (free in Europe): www.scienceinschool.org