



SCIENCE in SCHOOL

In this Issue:

Research into the Sun's atmosphere

Lucie Green investigates what happens when the Sun erupts

Also:

Dean Madden introduces younger students to fermentation – and ginger beer!

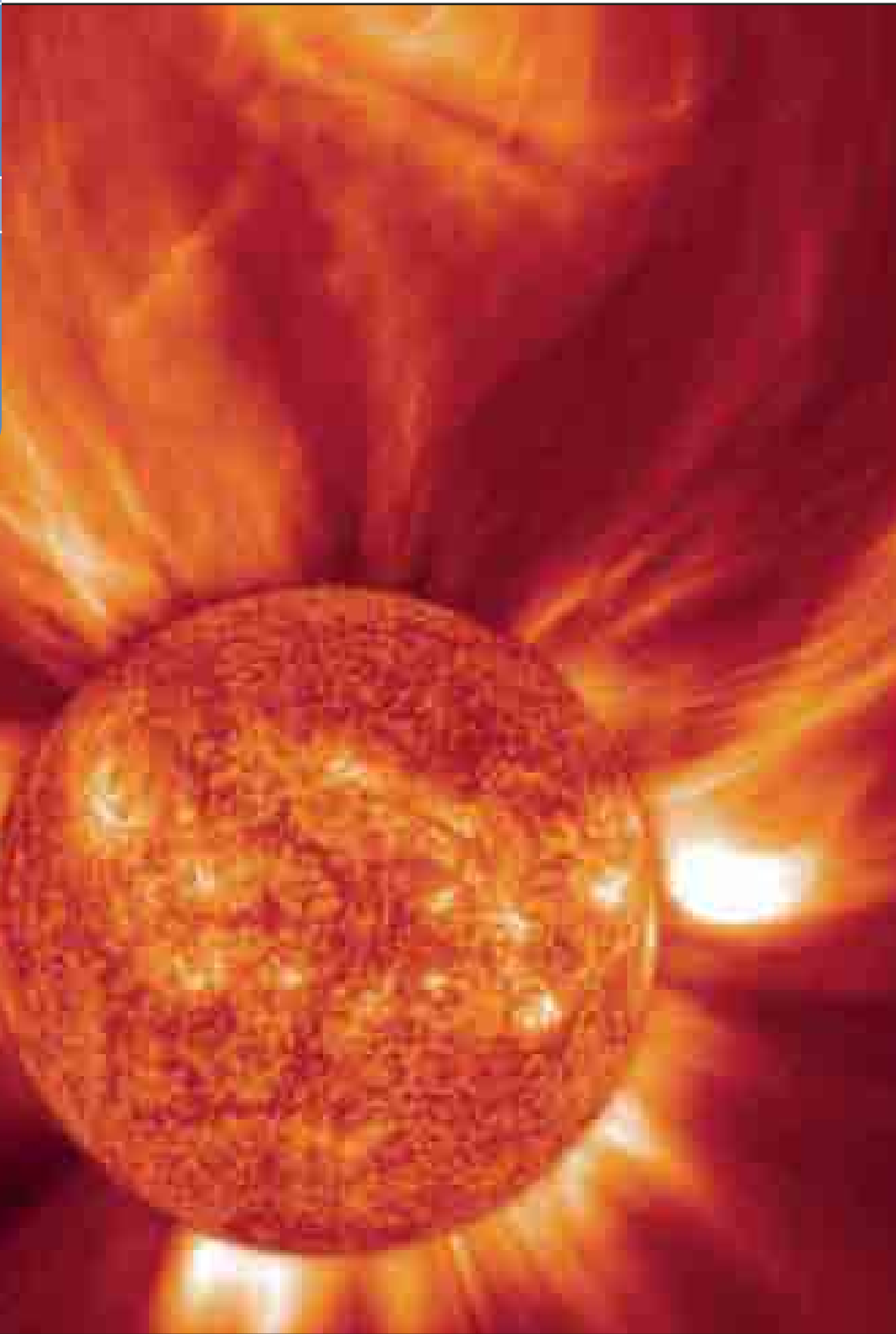

Highlighting the best in science teaching and research

Publisher

EIROforum
www.eiroforum.org

Editor

Dr Eleanor Hayes, European Molecular Biology Laboratory, Germany

Editorial Board

Dr Giovanna Cicognani, Institut Laue-Langevin, France
Dr Dominique Cornuéjols, European Synchrotron Radiation Facility, France
Dr Richard Harwood, Aiglon College, Switzerland
Russ Hodge, Max Delbrück Zentrum, Germany
Dr Rolf Landua, European Organization for Nuclear Research (CERN), Switzerland
Dr Dean Madden, National Centre for Biotechnology Education, University of Reading, UK
Helen Page, European Space Agency, the Netherlands
Dr Douglas Pierce-Price, European Organisation for Astronomical Research in the Southern Hemisphere (ESO), Germany
Dr Silke Schumacher, European Molecular Biology Laboratory, Germany
Dr Fernand Wagner, European Association for Astronomy Education, Luxembourg
Barbara Warmbein, Deutsches Elektronen-Synchrotron (DESY), Germany
Chris Warrick, European Fusion Development Agreement, UK

Assistant Editor

Dr Marlene Rau, European Molecular Biology Laboratory, Germany

Copy Editor

Dr Caroline Hadley

Composition

Nicola Graf, Germany
Email: nicolagraf@t-online.de

Printers

ColorDruckLeimen, Germany
www.colordruck.com

Layout Designer

Vienna Leigh, European Molecular Biology Laboratory, Germany

Web Architect

Francesco Sottile, European Molecular Biology Laboratory, Germany

ISSN

Print version: 1818-0353
Online version: 1818-0361

Cover Image

A widely spreading coronal mass ejection
Image courtesy of SOHO (ESA and NASA)

Contents

Events

Welcome to Valencia! The EU Contest for Young Scientists	2-7
--	-----

Feature article

Laboratory in space: interview with Bernardo Patti	8-12
--	------

Cutting-edge science

The Automated Transfer Vehicle – supporting Europe in space	14-20
---	-------

Life on Mars: terraforming the Red Planet	21-24
---	-------

Locking the cradle	25-28
------------------------------	-------

Teaching activities

Ginger beer: a traditional fermented low-alcohol drink	29-33
--	-------

Chewing flavours	34-37
----------------------------	-------

Projects in science education

Bring the fascination of the science centre into the classroom	38-41
--	-------

StandardBase: a Leonardo da Vinci pilot project for practical education and training in chemistry	44-47
--	-------

Science topics

What do we know about climate? Investigating the effects of anthropogenic global warming	48-51
---	-------

Research into the Sun's atmosphere	52-55
--	-------

Scientist profile

On the trail of a cure for cancer	56-59
---	-------

Salt of the Earth	60-62
-----------------------------	-------

Teacher profile

Paul goes back to the classroom	63-65
---	-------

Reviews

<i>Choosing Children: Genes, Disability, and Design</i>	66
---	----

<i>Nontraditional Careers for Chemists: New Formulas in Chemistry</i>	67
---	----

<i>Dance of the Tiger</i>	68
-------------------------------------	----



Welcome to Valencia! The EU Contest for Young Scientists

Anne MJG Piret from the European Commission assisted the jury during the recent EU Contest for Young Scientists.

The golden voice of Empar, one of the leaders of the student helpers, resonates through the enormous exhibition hall of the Prince Felipe Science Museum in Valencia, Spain. The venue is impressive.

Shouts of “Portugal, over here please!” and “Belarus, this way!” echo through the hall. The contestants at the European Union (EU) Contest for Young Scientists, hailing from across Europe and beyond, follow their stu-

dent leader to their reserved spots. The contest begins! It is up to the contestants to prepare their booths and present their projects.

Josef and Tomáš, from the Czech Republic, put their posters up and

First-prize winners: Abdusalam Abubakar, Florian Ostermaier, Márton Spohn and Henrike Wilms



What is the EU Contest for Young Scientists?

The EU Contest for Young Scientists is a high-profile event, open to young people aged between 14 and 21, who are the winners of national competitions. The contest gives these students the opportunity to compete with the best of their contemporaries at a European level. Although the demand for scientists and researchers is rising, the number of young people taking up scientific studies and careers is dipping. The organisation of events that mobilise young people from all over Europe and beyond is thus more important than ever.

The contest also gives Europe's best young scientific brains a forum to display their wares and connect with other like-minded students from other countries. It aims at rewarding scientific achievement and demonstrating to a wider audience that science is fun. Besides being an occasion for nurturing talent and enhancing young people's scientific and technological skills, it is also an opportunity for these young scientists to meet other youngsters with similar abilities and interests, but from a different country and perhaps speaking another language, and to be guided by some of the most prominent scientists in Europe.

How are projects chosen for the EU Contest for Young Scientists?

Only projects that have won a top prize at a national young scientist competition can participate in the EU Contest for Young Scientists. Project entries from all fields of scientific endeavour are accepted.

National competition organisers are responsible for selecting the projects and submitting the applications, and for all communication with the European Commission. Each participating country has an assigned national organiser who manages all applicants from their country. A list of the national organisers is available on the EU Contest for Young Scientists website^{w4}.

What constitutes a project?

Each project must consist of a technical written report, display materials and models. A group of up to six contestants may submit a project and each country may enter up to three projects. During the contest, the participants must set up their project on a display stand and are required to answer questions from members of the scientific jury. The science exhibition is open to the public.

BACKGROUND

create a booth featuring a special type of clutch for the motorcycle manufacturer Ducati. Angel from Spain turns his booth into a real Pantheon, including a model of the original building and a lamp as a substitute for the Sun.

Martina from Austria carefully decorates her booth with maize straw. Her environmental science project, 'Energy from maize straw', will later be awarded second prize, but at this stage her main concern is to make sure she presents her material effectively when the judges start their interviewing rounds.

At two o'clock, the jury rounds start. The 15 members of the jury have already read the project descriptions and discussed them in a meeting in Brussels. Now they have the opportunity to interview the



Some of the winning projects

The first prize was awarded jointly to three projects, from Germany, Hungary and Ireland.

Country: Germany

Contestants:

**Florian Ostermaier (19),
Henrike Wilms (20)**

Field: Physics

Project title:

Flashing Water Drops

Visiting a stalactite cave last summer, one of us made a strange observation: Every time a drop fell down from the top it seemed as if it would flash at a certain height. We didn't know the explanation for this, so we tried to reproduce the phenomenon at home. Our first idea was to use the drops falling down from the water tap. Quite accidentally, we found out that the effect only occurred when we put a light source in a very special position, shining towards the observer and the falling drop. Fascinated by this mystery, we started doing some research on the strange flash in the air. During our work we found out the relevant factors and we can know exactly under which conditions these flashes occur. In addition to that we succeeded in describing the phenomenon mathematically and we know now that the light reflections within a falling droplet change because the droplet itself oscillates. We also found out that this can be observed in any case where a drop detaches from anything, such as in the shower, at a water tap or when raindrops fall from gutters. With our research we found a completely new phenomenon that, as far as we know, has never been analysed.

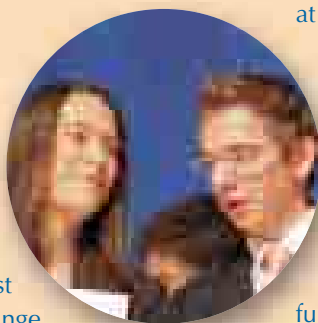

remained unnoticed: chemicals directly responsible for this effect cannot evaporate. My project was aimed at finding the reaction pathways taking place in the plant during an attack to convert the furanoterpenoids (chemicals responsible for self-defence) into volatile compounds. Experiments were made with plant extracts which mainly involved chromatographic methods to discover possible pathways. The experiment-based effect mechanism model of furanoterpenoids can explain the rapid reaction of the plant to an attack despite the fact that furanoterpenoid is produced very slowly. By discovering more details of floral self-defence, more environmentally friendly pesticides may be developed.

Country: Ireland

Contestant:

Abdusalam Abubakar (16)

Field: Mathematics

Project title: An Extension of Wiener's Attack on RSA Encryption

In 1990, Michael J. Wiener showed that if RSA (an algorithm for public-key cryptography) is used with a small decryption exponent, it can be successfully attacked. He based his attack on the properties of continued fractions, in particular on a very well known theorem of Legendre concerning the approximation of irrational numbers by simple continued fractions. In 2004, MJ Hinek proved that if a very large decryption exponent is used, the RSA system can be successfully attacked. Using a small decryption exponent, d , has the advantage of allowing rapid decipherment. It might be thought that this advantage could be retained by increasing d just beyond the range vulnerable to Wiener's attack. In attacks of the Wiener and Hinek types the condition must be obeyed for the success of the attack to be guaranteed. I shall refer to this condition as the ' $n^{1/4}$ barrier'. In this project I investigate attacks beyond the $n^{1/4}$ barrier. My project builds on Andrej Dujella's work. I generalise Dujella's inequality and I prove a number of theorems related to his extension of Legendre's theorem that form the mathematical basis for efficient Wiener- and Hinek-type attacks beyond the $n^{1/4}$ barrier.



Country: Hungary

Contestant: Márton Spohn (18)

Field: Chemistry

Project title: Examination of the Plants' Self-Defence Against Pests

Some plants, especially members of the mint family, can defend themselves against pests in a special manner: they emit scents that attract natural predators of the pests. This phenomenon was studied by biologists and chemists, but a contradiction

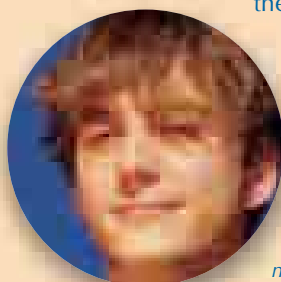

Image courtesy of the European Commission



Josef and Tomáš, from the Czech Republic

youngsters and ask them how they conducted their research, why they conducted it in the way they did, as well as how they chose their topic.

The young scientists are nervous, but at the same time eager to present their projects. They have been working on them for a long time, and have already won the national contest in their home country. What the contestants don't know, is that the jury members are almost as nervous as they are, and eager to meet these talented young people whose projects they have so far assessed only on paper.

Having fun!

At five o'clock, the jury members return from their first day's round of interviews, exhausted but very excited. The enthusiasm of the young scientists is contagious and the new jury members have difficulties disconnecting and preparing for an evening of entertainment. The contestants are better able to switch off, and together with the Spanish student helpers will show them how to set aside their stress – over a paella evening organised by their hosts.

Meeting real scientists

It has become a tradition in the EU Contest for Young Scientists to invite renowned scientists to meet and talk to the contestants. This year the European Commission also chose to invite scientists who are at the beginning of their careers, so they could provide an insight into their career paths and experiences of working as a young scientist.

EIROforum^{w1} (the publishers of *Science in School*) sent Freya Blekman, who works at CERN^{w2}. As a school ambassador for the EU-funded SET-Routes^{w3} project and an official CERN guide, Freya is clearly used to talking to non-specialists and students about science. Her lecture on the importance of particle physics and the role that a young scientist can play within the frame of an important scientific organisation such as CERN not only received very positive reactions, but also triggered a lot of enthusiasm amongst the young (and not so young) people in the audience!

The rewards

Another bright, sunny day greets the last day of the EU Contest for



Image courtesy of the European Commission

Martina from Austria

Young Scientists 2007 as everyone makes their way to hear the winners announced. The dolphins in the oceanographic museum seem almost as enthusiastic as the young people watching them. For a moment, the contestants forget the awards ceremony and their stress and enjoy their surroundings.

The final decisions were made the evening before, when the jury had the exceptionally difficult task of deciding on the winners of the cash prizes, the honorary awards and the special donated prizes. But ultimately, as in every competition, winners must be appointed, and the most outstanding projects were chosen from amongst 81 entries in a wide range of disciplines such as biology, chemistry, environmental science, social sciences, physics, molecular biology and engineering.

The master of ceremonies seems as nervous as the contestants. The press is pushing at all sides to find the best position for taking photographs of the winners and we are all very excited!



Image courtesy of the European Commission

Angel from Spain



EIROforum prizes

The seven European intergovernmental research organisations that make up EIROforum also awarded prizes: a one-week visit to the respective research organisation.

CERN: The European Organization for Nuclear Research

Country: United Kingdom
 Contestant: Galen Brown (17)
 Field: Engineering
 Project title: FSC11 – The flexible TV standby controller

EFDA: The European Fusion Development Agreement

Country: Turkey
 Contestant: Mustafa Taghiyev (16)
 Field: Mathematics
 Project title: The Integer Values Of Algebraic Expressions And Some New Properties Of Binomial Coefficients

EMBL: The European Molecular Biology Laboratory

Country: Austria
 Contestant: Philipp Zagar (18)
 Field: Chemistry
 Project title: Synthesis of a linker molecule for self-assembled monolayers (SAM)

ESA: The European Space Agency

Country: Germany
 Contestant: Raphael Errani (17)
 Field: Physics (Astronomy)
 Project title: Impact Probability of Asteroids on Earth

ESO: The European Organisation for Astronomical Research in the Southern Hemisphere

Country: Slovakia
 Contestant: Ľubomír Urbančok (17)
 Field: Physics (Astronomy)
 Project title: The study of symbiotic star BF Cygni

ILL: The Institut Laue-Langevin and ESRF: The European Synchrotron Radiation Facility

Country: Lithuania
 Contestants: Milda Jurėnaitė (19) and Rasa Briedytė (19)
 Field: Chemistry
 Project title: Zinc and zinc alloy galvanic coatings: structure homogeneity determines resistance to corrosion



The background to the contest

For the past two decades, the EU, via its framework programmes, has supported science and technology and encouraged co-operation between European researchers. The EU also recognises the need to start the process of integration at the grass-roots level. The European Commission actively supports young people's interest in science and promotes European co-operation in the fields of education and training.

To meet the objective of the European Research Area – to co-ordinate national research policies in the direction of shared objectives, expertise and resources – the heads of state and government have confirmed a need

to increase the global expenditure on research to 3% of gross national product – or one and a half times the current level – by 2010. This substantial increase will enable Europe to bridge the gap with the United States and Japan and help create a uniform concept of European research similar to the single European market.

The EU Contest for Young Scientists plays an essential role in the development of a pan-European scientific community. Over the years it has generated excitement and has gone some way to popularising science among the young.

BACKGROUND

Finally, the winners are announced (see box 'Some of the winning projects'). Some of the young scientists are visibly astonished. Some are surprisingly at ease in front of the cameras, others burst into tears of joy and fall into each others' arms, but all of them are clearly overjoyed with their prizes.

The 19th EU Contest for Young Scientists is over, but for many of the young scientists participating in this event, it will remain much more than a competition. Many of them learned to work in a team, became interested in other fields of science and made new friends. For all of the contestants, the EU Contest is undoubtedly an unforgettable and rewarding experience.

Web references

w1 – EIROforum, which publishes *Science in School*, is a partnership of Europe's seven largest intergovernmental research organisations. See www.eiroforum.org

w2 – CERN is the world's largest particle physics laboratory. See www.cern.ch

w3 – The SET-Routes project aims to encourage more girls and women to study science, engineering and technology and to help them further their careers. As part of the ambassador programme, young female scientists visit schools and universities. For more details, see www.set-routes.org

w4 – For more information on the EU Contest for Young Scientists in general and the 2007 contest in Valencia, see <http://ec.europa.eu/research/youngscientists>

Resources

For details of the 20th contest in September 2008, see www.eurocontest.dk



Image courtesy of ESA



Laboratory in space: interview with Bernardo Patti

Bernardo Patti is the Columbus mission manager at the European Space Agency. He is an engineer and worked at nuclear power plants before going into space technology. Shortly before Columbus was launched, he talked to **Anna-Lynn Wegener**.



Images courtesy of ESA

What is Columbus?

Columbus is the name of a research laboratory that we will send into space to dock with the International Space Station [ISS]^{w1}. It is an add-on module to the station, that contains all the facilities to carry out experiments in space. It will be on board the Space Shuttle Atlantis, which will be launched in early 2008 from the Kennedy Space Center in Florida.

What does such a space laboratory look like?

Columbus has a cylindrical shape. It is around 7 metres long and 4.5 metres in diameter. Equipment inside is packed very efficiently.

We had to work very hard to come up with the best design that would

make the most efficient use of the 75 m³ volume. It can now fit three crew members and contains all the essential research equipment. The individual research facilities accommodate very high-tech racks with drawers of equipment and workspace that can be pulled out.

What kind of research will be done with Columbus?

Columbus is a multidisciplinary laboratory. It contains four different facilities to carry out experiments in material science, fluid science and life science. In all of these fields we want to study the effect of weightlessness on different samples that we are sending from Earth.

Biolab, for example, is a facility for biological experiments on micro-organisms, cells, tissues, small plants and invertebrates. We want to find out what effect gravity – and the lack of it – has on all levels of living organisms. One of the first experiments we will do within Biolab is to observe how the roots of a small plant – you can imagine it a bit like rocket [rucola] – will grow. Will they grow up, down or in a completely different direction when not guided by gravity?

In the European Physiology Module contained in Columbus, the effect of long-duration spaceflights on the human body and health will be tested. We also hope to gain some insights into terrestrial problems such



Image courtesy of ESA

Image courtesy of ESA

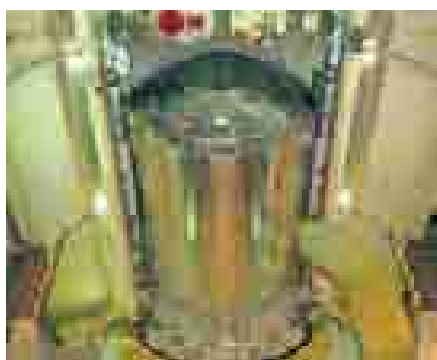

as the processes of ageing, balance disorders, bone osteoporosis and muscle dystrophy.

The Fluid Science Laboratory will hopefully reveal dynamics of fluids that cannot be studied on Earth, because they are masked by gravity and its effects. We will be looking at,

among others, phenomena like flows and instabilities induced by surface tension gradients and thermal radiation forces, instabilities related to coupling between heat and mass transfer, thermo-physical properties of fluids, mechanisms of boiling and critical point phenomena.

In the Material Science Laboratory, experiments will be run to explore different materials to improve the study of their properties. We will melt and solidify metals and expose them to different atmospheres and conditions.

Isn't it a lot of effort to send terrestrial samples into space to study them?

It definitely is a lot of effort, but it is worth it. All of the questions we are

investigating could never be addressed in laboratories on Earth, because gravity is such a pervasive force on our planet. I know it sounds paradoxical that it is easier to understand some terrestrial phenomena in space, far away from their natural context, but gravity makes some experiments simply impossible and overrides many small effects that can be studied in orbit.

What are the challenges of a mission like Columbus?

The foremost challenge was constructing a laboratory that on Earth would weigh at least 50 tonnes with a diameter of just over four metres while keeping it light enough to be sent into space. Columbus weighs



around 12 tonnes and that is about the maximum weight the Atlantis shuttle can carry.

On Columbus we have been able to provide an environment where the crew can work in comfortable surroundings. Apart from this it is able to accommodate all the scientific facilities in the pressurised space. It can operate for 10 years in orbit. Unlike a ship that needs to be dry docked and then repaired, Columbus will have the capability to automatically detect any failures and to start self-repairing while still being operational. The entire European structure can be operational with just a single launch.

What excites you personally about the project?

As an engineer, I was particularly attracted by the design and engineer-

ing challenges involved. But space and weightlessness also carry an inherent fascination: engineering and travelling into space share the fact that they overcome traditional barriers of technology and mankind. It is incredibly exciting and a huge step for space exploration.

On a more day-to-day basis, what I really love about the project is its internationality. The International Space Station is a collaborative project of five different space agencies. Apart from the European Space Agency, (ESA), which by itself has 17 European member states, the US National Aeronautics and Space Administration (NASA) and the Canadian, Russian and Japanese space agencies are also involved. Every day I talk to people from many different countries, sometimes speaking several languages a

day. It is rewarding for us to see so many nations putting so much effort into the realisation of such an ambitious project and to see healthy competition developing between nations.

Curiosity and science go beyond national borders and historic differences. They are strong, uniting forces that bridge geographical and cultural gaps.

Is there any way that teachers and school kids can benefit from Columbus?

At the moment we are focusing on getting Columbus safely up to the ISS and the first periods will be dedicated to setting it up and running experiments. But it might well be that in future we will broadcast lessons from or involving the Columbus module, just as has been done from the ISS



Image courtesy of ESA



As we go to press: the Columbus module has joined the ISS

Atlantis safely returned to Earth with its crew of seven on 20 February, after spending almost 13 days in space, including nine days docked to the ISS, to deliver Europe's first permanent human outpost in orbit. Two ESA astronauts, Hans Schlegel of Germany and Léopold Eyharts of France, travelled to the ISS; Schlegel returned to Earth with Atlantis but Eyharts became part of the resident ISS crew and will return to Earth in late March after performing a series of experiments, both in the laboratory and in the other science facilities already operating in the Station.

ESA will continue to contribute to ISS operations by launching unmanned Automated Transfer Vehicles (ATVs), designed to deliver scientific experiments, crew support equipment (such as food and clothing), fluids and propellant. The first ATV, *Jules Verne*, will be launched by an Ariane 5 rocket on 8 March^{w2}

As Columbus comes to life, so too does the network of nine User Support and Operations Centres (USOCs) throughout Europe, which facilitate the interface between researchers and the science payloads on board, and allow investigators to control their experiments and receive real-time data on their results. As more science payloads are delivered to Columbus by upcoming logistics missions, the USOC network will become more active.

Columbus was designed to support some 500 experiments per year for ten years, in cell and plant biology, astrobiology, human physiology, fluid and material sciences, fundamental physics, astronomy, remote sensing and technology. For the European science community and industrial R&D, a new era of research has just begun.

[see the Resources section]. Columbus opens up countless new possibilities, some of which I am sure we cannot even conceive yet.

Web references

w1 – An article about the International Space Station will be available in a future issue of *Science in School*. Keep visiting www.scienceinschool.org

w2 - For more information about the Automated Transfer Vehicles, see the following article in this issue of *Science in School*:

Williams A (2008) The Automated Transfer Vehicle – supporting Europe in space. *Science in School* 8: 14-20. www.scienceinschool.org/2008/issue8/atv

Resources

ESA have produced many educational materials relating to the International Space Station (ISS):

- A printed ISS education kit for both primary- and secondary-school teachers is available in all 12 ESA languages. The kits are based on all the fascinating activities involved in building, working and living on board the ISS, and provide background information and exercises for classroom teaching. They are available to all school teachers in ESA member states and can be



ordered free online: www.esa.int/spaceflight/education

- An interactive version of the ISS education kit is available here: www.esa.int/spaceflight/education
- A series of ISS DVD lessons cover topics relating to European school curricula. One about the Automated Transfer Vehicle is due to be released in summer 2008. The DVDs can be ordered free by teachers: www.esa.int/spaceflight/education
- ESA is also developing a series of online lessons for primary- and secondary-school students and their teachers. See: www.esa.int/SPECIALS/Lessons_online

Further details and education materials can be found on the:

European Space Agency Education website: www.esa.int/esaED/



REVIEW

This article could start wonderful discussions about gravity, micro-gravity or free-fall conditions, how gravity on Earth affects chemical and physical behaviour of substances and bodies in Earth-based experiments, and how we can reproduce an almost gravity-free environment orbiting the Earth. The so-called Einstein equivalence principle immediately comes to mind, prompting one to wonder how free-fall can be equivalent to the absence of gravitational pull. Human body behaviour in space and after re-entering a terrestrial environment can involve life science and chemistry in an amazing interdisciplinary space party.

Marco Nicolini, Italy

and the

European Space Agency Human Spaceflight Education website: www.esa.int/esaHS/education.html





Image courtesy of ESA

The Automated Transfer Vehicle – supporting Europe in space

Where do astronauts get their food? What happens to their waste? **Adam Williams** from the European Space Agency in Darmstadt, Germany, describes the development of an unmanned shuttle to supply the International Space Station.

Image courtesy of Transport for London

Imagine a double-decker bus driving from the outskirts of London to Wembley Stadium. We pick up its journey just outside Windsor (where the Queen lives), 30 km from Wembley, and watch as it drives slowly into the centre of London. As

it reaches Hanger Lane, around 3.5 km from its destination, it pauses for a few minutes, before continuing along the North Circular Road and up Harrow Road, until it is within sight of the stadium, about 0.25 km away. Finally it spends almost half an hour

inching its way to a reserved parking slot. Once it is safely parked, we look inside the bus – and realise there is no driver.

Now move this journey 350 km into space, and substitute, for the stationary Wembley Stadium, the

International Space Station (ISS), which covers approximately the same area as the football pitch but moves at over 27 000 km/hour. The bus-sized vehicle approaching the ISS is the Automated Transfer Vehicle (ATV), designed by the European Space Agency (ESA) to fly to, and automatically dock with, the ISS. During its final approach it glides in with a relative speed of less than 0.25 km/hour, and with a positional accuracy of better than 10 cm.

The ISS is a multi-national project aimed at building and sustaining a laboratory in which experiments can be performed in microgravity. Gravity on the ISS is not completely zero, because of very small forces caused by such things as the mass of the ISS itself and reaction to friction from the atmosphere. The experiments have been concerned mainly with the long-term effects of microgravity on the human body. Scientists also plan to use the ISS to examine the effect of microgravity on the physics of fluids, on combustion and on the behaviour of aerosols, ozone, water vapour and oxides in Earth's atmosphere, as well as cosmic rays, cosmic dust, anti-matter and dark matter in the Universe.

The long-term goals of this research are to develop the technology necessary for human-based space and planetary exploration and colonisation (including life support systems, safety precautions and environmental monitoring in space, for example), new ways to treat diseases, more efficient methods of producing materials, more accurate measurements that would be impossible to achieve on Earth, and a more complete understanding of the Universe.

The ISS will have a permanent crew of six astronauts (until April 2009 there will be only three crew members permanently on board). Crew and supplies are transported to and from the ISS using either the NASA Space Shuttle or the Russian Space Agency Soyuz vehicle. Supplies



Image courtesy of ESA – D.Ducros

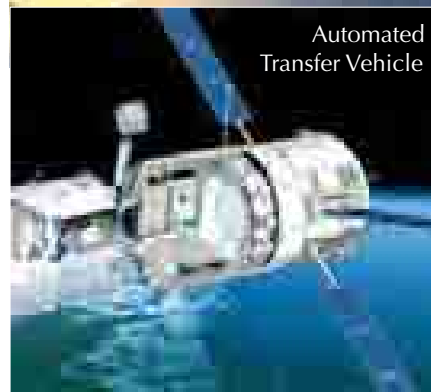

Image courtesy of ESA

can also be transferred using the unmanned Russian Progress vehicle.

The ATV – the most complicated spacecraft ever built, launched and operated by the European Space Agency – will supplement these vehicles, and help to pay ESA's share of the ISS operating costs.

Several ATVs are planned. The first, named *Jules Verne* after the famous French science fiction writer, will be launched on an Ariane 5 launcher from French Guyana^{w1}. As this article was prepared, the launch was planned for 9 March 2008 and the ATV was scheduled to dock with the ISS on 3 April 2008^{w2}.

Vehicles that dock with the ISS normally have some manual control of the final docking manoeuvres. The Space Shuttle and Soyuz are controlled by a pilot on board; Progress is

controlled by ISS crew members. ATV will be the first vehicle to dock completely automatically. Although the ATV will be monitored closely during its approach and docking by ground controllers and ISS crew, it is designed to handle autonomously any emergency situation without damaging itself or the ISS, or endangering the ISS crew.

ATV is designed to carry over nine tonnes of experiments, equipment, fuel, water, food and other supplies from Earth to the ISS orbiting around 350 km above Earth. The first flight cargo will include spare parts for the European Columbus laboratory^{w3} and the ATV itself, personal items for the crew, and a luxury 19th century edition of the book *De la Terre à la Lune* (*From the Earth to the Moon*) written by Jules Verne.

Once attached to the ISS, ATV will become a 22 m³ extension to the ISS, providing extra living space for the ISS crew. While attached, the cargo of experiments will be transferred to the ISS, along with more than 810 kg of water, 100 kg of nitrogen, oxygen and air and nearly 860 kg of ISS propellant. ATV will also use its thrusters to correct and adjust the orbit of the 400



Training for launch

Image courtesy of ESA



ATV Control Centre

Before ATV can be launched, the ground control teams at the ATV Control Centre in Toulouse, France, together with ISS control teams in Houston, USA, and Moscow, Russia, plus representatives of the ISS crew, need to undergo a series of training simulations. The following gives a flavour of what they go through during a typical simulation day.

05.00 CET: An operator in Toulouse starts the simulator, which simulates the ATV spacecraft, the ISS, the US satellite communications network TDRS, the ESA communications satellite Artemis and parts of the ESA and Russian Ground Station network. It comprises three parts, running in three control centres. In Moscow and Houston other operators also prepare their computers, ready for a multi-national training session.

06.30: The teams arrive for the briefing. The intercom system connecting the sites is checked.

06.52: There are difficulties with the simulator in Toulouse, delaying the start of the simulation. The operator spends anxious minutes tracking down the problem. If the simulator cannot start properly, it will be necessary to reconvene scores of engineers who have gathered around the globe to participate.

08.05: The GO button is pressed, and the simulators begin sending data. Docking will occur in about seven hours; before then, the simulation covers an approach to the ISS, culminating in an 'Escape' manoeuvre which proves that docking can be stopped if necessary.

08.41: The training instructors in each control centre privately confer over the impact of the delayed start. Houston can only participate for eight hours, after which their facilities are required for Shuttle training. The instructors decide to advance one of the planned contingencies to ensure that the necessary training is achieved.

11.28: ATV starts a series of homing boosts. A problem is reported with data from the communications centre in Oberpfaffenhofen, Germany. Unknown to the trainees, a failure in the communications link between Oberpfaffenhofen and Toulouse has been introduced. There is a flurry of

calls over the intercom, and ground controllers rapidly deal with the problem.

14.18: ATV approaches the ISS, gathering calibration data for the optical sensors used to control the final docking. Suddenly an urgent voice can be heard on the intercom: "This is an emergency". Toulouse has lost all communication with the spacecraft.

14.25: The failure is traced to a problem with TDRS – deliberately injected by the instructor. He judges how long to leave the teams in this critical situation, and then fixes the problem. Now Toulouse must command ATV to pull away from the ISS and repeat the closing manoeuvre, to gather again the vital calibration data lost during the communications outage.

15.29: The planned 'Escape' manoeuvre is commanded. ATV manoeuvres harmlessly away from the ISS and the simulation is over. The flight directors and training instructors have a four-way discussion over the intercom system, identifying the key successes and failures, and anything that needs to be improved or changed.

Despite a delayed start, and a long, hard day, the team are clearly pleased with their achievements. They mill around the main control room, congratulating themselves on having dealt successfully with the problems thrown at them. They have demonstrated their expertise in controlling the most complex spacecraft ESA has ever built, and as their confidence grows, they move one step closer to the ATV mission.



Image courtesy of ESA

International Space Station: At certain times during its orbit, the ISS is visible with the naked eye

tonne ISS. This is necessary because even though there is only a very small amount of atmosphere at an altitude of 350 km, the ISS is so big that it causes some drag. Every so often, the ISS needs to be boosted up to a higher altitude, from where it drifts lower and lower. Without this, the ISS would eventually fall out of the sky. ATV will also be used for emergency manoeuvres, such as those required if a piece of space debris is predicted to hit the ISS.

After about six months, ATV will be loaded with solid and liquid waste from the station (use your imagination! Those empty tanks may as well store something). It will then be undocked from the ISS, and directed back towards Earth where it will burn up harmlessly in the atmosphere over an uninhabited area of the Pacific Ocean.

Since ATV will approach and be attached to the ISS, the safety of the crew on board the ISS is paramount. Most spacecraft functions are doubly

redundant, meaning that each subsystem, unit, switch and valve is duplicated so that the spacecraft can withstand any single failure. When people are involved, systems must be triply redundant; ATV is thus designed to cope with two simultaneous failures. This obviously increases the cost and weight of the spacecraft, although it is difficult to quantify by how much.

For example, ATV has a thruster system with main and redundant thrusters to guide it as it docks with the ISS. In case both the main *and* redundant thrusters fail, it has a separate alternative thruster system, controlled by completely different hardware and software.

This system will be used particularly if it appears that ATV is not going to dock properly with the ISS. This could be due to a system failure within ATV or because its velocity is not as expected, or may be necessary if there is an independent problem on the ISS (such as a fire alarm). Ground controllers at the ATV Control Centre

in Toulouse, France, the ISS crew or ATV itself can instruct the thruster system to steer the vehicle safely away from the ISS. The controllers then assess the situation. If fully understood and correctable, they would instruct ATV to circle above and behind the ISS and come back for a second attempt. If not fully understood, ATV would be parked 2000 km ahead of the ISS for further investigation.

Much of the complexity of the *Jules Verne* mission comes from proving that these safety systems work correctly. Only when all of the vital safety operations have been demonstrated to perform flawlessly, will ATV be allowed to dock with the ISS (see box 'Training for launch').

The mission will start with the launch and early operations phase (LEOP), when the spacecraft will be put into a low Earth orbit by an Ariane 5 launcher. This is probably the riskiest part of the mission, especially until ATV has deployed its four



Approaching the ISS

ATV's journey to the ISS will be characterised by a series of station keeping points – places in space where ATV pauses and ground controllers check that everything is OK before continuing. This could be compared with a postman delivering mail. The postman doesn't know if a fierce dog is locked up or is going to attack him: he gets to the end of the road (pauses and checks everything is OK); he gets to the gate (pauses and checks again); he gets to the front door step (pauses again); he opens the letter box and posts the letter. If at any point the dog appears (or it starts raining, he drops the postbag or he finds the address is wrong), he runs away!

The station keeping points are numbered from S_{-5} , which is the start of proximity operations with the ISS (ATV is then around 100 km from the ISS), to S_{41} , which is only 12 m from docking.

When ATV reaches $S_{-1/2}$ (around 40 km behind and 5 km below the ISS), global positioning system receivers on ATV and the ISS will be used to calculate their relative positions. ATV will then pass through S_0 (30 km from the ISS) and stop at station keeping point S_2 , located 3.5 km behind and 100 m above the ISS.

When all checks at S_2 have been completed, an 'Escape' manoeuvre will be initiated to demonstrate the correct operation of the safety manoeuvre, after which ATV will circle around the ISS and return to $S_{-1/2}$. Two days later, a second demonstration phase will be initiated. This time, ATV will approach S_3 , 280 m behind the ISS.

Further checks will be performed at S_3 , and ATV will switch to using a visual system to control its final approach. Before docking can be attempted, a series of hold and retreat commands will be demonstrated, to ensure that the crew or ground controllers can stop an unsuccessful docking attempt if necessary.

Having successfully retreated to S_3 , ATV will continue to S_4 , which is 25 m from the ISS, and then to S_{41} , a mere 12 m away. Again, a retreat to S_4 will be commanded, and finally an 'Escape' manoeuvre, the ultimate abort test, which will leave ATV again circling the station and returning to $S_{-1/2}$.

At last, the final approach will be commanded, and ATV will dock with the ISS.

BACKGROUND



ATV initial approach

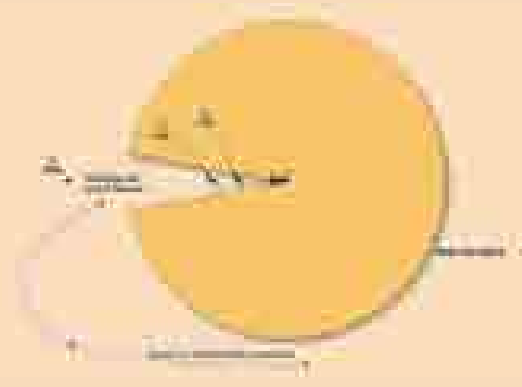

ATV final approach

Images courtesy of ESA

solar array panels used to generate the power necessary to control the spacecraft. Although ATV has batteries to provide power until the solar arrays are available, they will eventually run out of power; if the arrays don't work, the spacecraft would fail and the whole mission would be lost.

After LEOP, the spacecraft will perform a series of manoeuvres to bring its orbit in phase with the ISS, approaching it from behind and slightly below.

The approach to the ISS will be characterised by a series of waypoints and station keeping points (see box 'Approaching the ISS'). About 15 days

after launch, the final approach and rendezvous will begin and ATV will automatically dock with the ISS (see box 'Russian docking system') following checks at each station keeping point. ATV is designed to cope with a vast range of simultaneous problems without causing damage to itself or the ISS. Everything is autonomous –

Image courtesy of ESA



Engineers work on Jules Verne ATV's docking mechanism

the control team and crew are there just to keep an eye on things in case something goes wrong.

Once attached, the spacecraft will be monitored using data sent via the ISS to the control centre in Toulouse; the software on board ATV and in Toulouse can detect unexpected situations – anything from the air circulation fans failing to a fire.

Finally, all good things must come to an end. ATV will undock from the ISS and plunge to its fiery demise in the upper atmosphere. But this is no one-off mission. The design and operations concept proved during the *Jules Verne* mission will be used to build and fly at least four more ATV spacecraft. Subsequent ATVs will be launched approximately once a year, resupplying the ISS and providing



Russian docking system

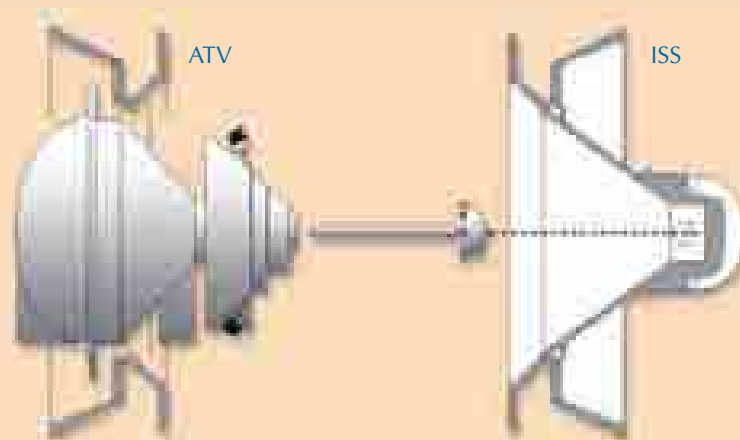

BACKGROUND

The ATV docking system is a Russian system, also used on Russian vehicles, and designed for use with the docking port on the Russian ISS module.

As ATV approaches the ISS, a probe at the front of the vehicle is extended. The tip of the probe has sensors which detect contact with the docking port on the ISS. When contact is detected, the ATV initiates a thrust which pushes the vehicle into the docking port. When

the probe reaches the end of the docking port cone, the vehicle brakes and latches on the probe engage with the docking port.

The probe is then retracted, which brings ATV and ISS together, after which hooks on ATV automatically engage with the ISS. Finally, hooks on the ISS engage with the ATV, and the two bodies become a single rigid structure.

Image courtesy of ESA

Image courtesy of ESA



Solid rocket booster arrives for integration with the main cryogenic stage for Jules Verne's Ariane 5 ES launch vehicle

vital support to the ISS programme into the next decade.

Web references

w1 – To watch a video of an Ariane 5 launch, see: www.scienceinschool.org/2008/issue8/atv

w2 - For more information about the ATV, see: www.esa.int/SPECIALS/ATV/index.html

w3 – For more information about the Columbus laboratory module, see the interview with Bernardo Patti in this issue of *Science in School*:

Wegener A-L (2008) Laboratory in space: interview with Bernardo Patti. *Science in School* 8: 8-12. www.scienceinschool.org/2008/issue8/bernardopatti

Resources

To construct your own model of the ATV, see:

http://esamultimedia.esa.int/docs/atv_model/ATV_2002.htm

To find out when the ISS can be seen from where you are, see www.esa.int/seeiss

Adam Williams is a training and simulation manager at the European Space Agency. Previously a software engineer, and for a while a secondary-school mathematics teacher, he is based at ESA's space operations centre in Darmstadt, Germany. Adam currently spends half his time in Toulouse, France, home of the ATV Control Centre, supporting the launch preparations for ATV.



REVIEW

The article is mainly about the automated transfer (space) vehicle (ATV), designed to dock automatically with the International Space Station (ISS). Though there are aspects of ATV's trajectory between launch and docking that relate to pre-university physics (mechanics), the topic of most interest – to technology teachers – may be the sensing and control systems.

The purpose of the ISS, on the other hand, includes a number of aspects of interest to teachers of pre-university physics – and a further article devoted to the ISS is planned for a future issue.

Even so, many science (and technology) teachers will enjoy this article and some learners will find it of much interest too. Below are some ideas about how it could be used.

'The effect of microgravity on the physics of fluids, on combustion, on the behaviour of aerosols' – this could lead to a group discussion on what the effect might be (for instance, in the cases of convection, a burning candle, and diffusion in a gas, respectively).

'Cosmic rays, cosmic dust, anti-matter, and dark matter in the Universe' – students could do library or web research on the nature (and importance) of these, leading perhaps to class presentations.

The sensing and control aspect would be suitable for technology rather than science curricula – and there is enough here for a whole lesson of varied activities and approaches.

Eric Deeson, UK

Life on Mars: terraforming the Red Planet

Science fact or science fiction? **Margarita Marinova** from Caltech, USA, investigates the possibility of establishing life on Mars.

Image courtesy of NASA Ames Research Center (NASA-ARC)



The surface of Mars – devoid of liquid water and life

Early astronomers gazed at Mars and thought they saw a planet criss-crossed by irrigation canals and vegetation. One hundred years later, in 1964, the Mariner 4 spacecraft reached Mars. The disappointment for scientists must have been bitter, as they saw a barren world with no signs of vegetation, water or life. To those scientists, the idea of a wet Mars covered by plants suddenly seemed like science fiction.

In the 40 years since Mariner 4, we have learned a lot about Mars from the many spacecraft that have been sent to the Red Planet. We now know

that Mars' surface temperature varies between -143°C at the poles and $+27^{\circ}\text{C}$ at the equator. Mars has a very thin atmosphere (about 1% of Earth's pressure), no liquid water, and the incident UV radiation combined with the highly oxidising regolith make Mars' surface a deadly place for life. However, from images showing large river channels and networks, and the Mars Exploration Rovers showing layered sediments and alteration of the layers by water, we have learned that in the first half billion years of its history, Mars was a warm, wet place with a thick atmosphere. So could

Mars be made habitable again?

This is the premise of terraforming – changing a planet to make it habitable to Earth-like life (terra = Earth). The idea of terraforming was first suggested in the 1930s – purely in the science fiction domain. However, in the 1960s, scientists started thinking about the idea more seriously. Is this really feasible? Can it be done with current technology?

To answer the question of whether terraforming Mars is possible, we must first look at what is required for life and if Mars has these basics. Mars currently cannot support liquid water



Mars' North Polar Cap: made of frozen carbon dioxide and water

Image courtesy of NASA Glenn Research Center (NASA-GRC)

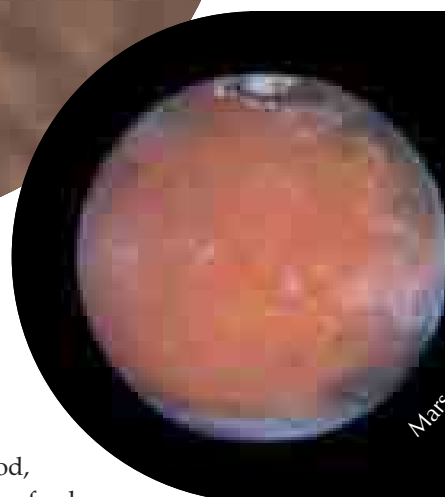

Mars, the Red Planet

Image courtesy of NASA Jet Propulsion Laboratory (NASA-JPL)

on its surface due to its low temperatures and thin atmosphere (the atmospheric pressure is below the triple point of water, the pressure below which a material can only exist as a solid or vapour, regardless of the temperature). In addition to liquid water, the most basic life on Earth needs only an atmosphere with which to exchange gases. More complex organisms have more stringent and numerous requirements – plants need small amounts of oxygen, animals need a higher atmospheric pressure – but micro-organisms are low-maintenance.

Mars has frozen carbon dioxide (CO₂ ice) in the polar caps and absorbed into the ground, which would be released if the planet were warmed. This would thicken the atmosphere, and also further warm up the planet. The warming would also cause the frozen water that has been detected at the polar caps to melt. So Mars does seem to have the

two key ingredients needed to sustain life. Not only that, but once Mars were initially warmed by some method, there would be a positive feedback in the release of carbon dioxide from the polar caps and regolith, the thickening of the atmosphere, the further warming of the planet, the release of water, and the consequent conditions that allow liquid water to persist on the surface.

How could we warm Mars or force the frozen carbon dioxide to be released into the atmosphere? Many ideas have been proposed, such as: putting mirrors in orbit around Mars to reflect extra light onto the Martian surface, thus warming it up; sprinkling dark dust on the poles to decrease their albedo (i.e. brightness) so that more of the Sun's energy is absorbed; and releasing super-greenhouse gases into the atmosphere to warm up the planet. There are groups

working on making the first two of these ideas technologically feasible. But we have already implemented the greenhouse gas idea on Earth – making it, at least for now, the most promising terraforming method.

Super-greenhouse gases are molecules which are very effective at absorbing energy released by the surface of the planet, and then re-radiating this energy both upwards into space – to be lost forever – but also downwards towards the surface of the planet, thus further heating it. They work in a similar way to a blanket. But we don't want just any blanket! For example, carbon dioxide would be like a thin sheet whereas a super-greenhouse gas, like perfluoro-



A key feature of good science-fiction writing is that no matter how fanciful the idea, it must be theoretically feasible, such that at some future date the onward march of technology turns futuristic fiction to everyday fact. Margarita Marinova of Caltech details the feasibility of the sci-fi-sounding prospect of terraforming Mars – making conditions on the Red Planet more similar to our blue one, in the hope of sustaining (human) life.

Most students have an inherent interest in astronomical matters as well as in environmental issues, and the article neatly straddles both domains, incorporating aspects of the three traditional strands of science, together with geology. There is also scope for the ethics of terraforming to be covered in personal, social and health education (PSHE) lessons. Alternatively, artists could create illustrations of what a recently greened Red Planet could look like, and perhaps see how these compare with illustrations produced in the middle of the last century.

The article lends itself to use as a comprehension exercise or as a stimulus for class debate, where a variety of questions can be devised which cut right across the traditional science subdivisions. Comprehension questions could include:

- Find where ‘positive feedback’ is mentioned in the article. Explain what this means in the context of the article. Find another example of positive feedback (not in the article). Is the outcome of positive feedback always good?
- Which three methods of heating the Red Planet are mentioned? What are the possible pros and cons of each?

- How would human timescales change if we lived on Mars? How would day and night lengths compare? Would we still have seasons? How long would a year be? How does gravity’s strength compare between Earth and Mars, and would this have any effect on Martian sport, for example?

You could also wander into the realm of moral rights and wrongs of carrying out this planetary makeover. The big question of ‘should we?’ should generate a lot of discussion, and students could be asked to consider if their response to the question could depend on circumstances. For example, would it still be morally wrong to terraform Mars if life on our home planet was in terminal decline, and there was nowhere else for the human species to go? As mentioned above, this could form part of an ethics debate in PSHE lessons, and a larger scale example than the standard ‘right to life’ debate that tends to be used when science and ethics domains meet.

As well as a good introduction to the topic, this article is a useful starting point for further research, should the idea stimulate students’ interest. They may want to watch clips of *An Inconvenient Truth*, in which Al Gore discusses greenhouse gases, and suggest how there could be a silver lining after all, in the global climate change cloud. Or they could investigate Mars further: how do we know what we know about Mars, given that no human has ever visited it? What plans currently exist to send people to Mars? What are the challenges of such a mission, and how do they compare with the challenge faced in the 1960s and 1970s to send men to the Moon? Finally, students could be asked to find examples of historical science fictions that have already become science fact.

Ian Francis, UK

REVIEW

propane (C_3F_8), would be like a thick wool blanket. So we would want to use super-greenhouse gases – with high warming potentials, and also long atmospheric lifetimes (1000s to 10 000s of years) – to reduce the required replenishment rate. A final key aspect is to choose super-greenhouse gases that do not destroy Mars’ natural current – and future – ozone layer (unlike chlorofluorocarbons, or CFCs).

Detailed atmospheric models show that one of the best super-greenhouse gases to use is perfluoropropane, and the total amount needed is about 26 000 times the amount of similar gases (CFCs, perfluorocarbons and hydrofluorocarbons) released on Earth by industry every year. This means that we cannot produce the gases on Earth and then ship them to Mars. Instead, the gases will have to be made on Mars. Consequently, ter-

raforming Mars would likely commence when we start colonising Mars and there is both the incentive and the industrial power to create the factories necessary for producing the super-greenhouse gases.

Greenhouse gases are currently drastically – and undesirably – changing the Earth, so using them on Mars may seem irresponsible or just wrong. However, changing the climate on Earth is undesirable because there is

An artist's conception of a terraformed Mars



Image courtesy of Michael Carroll / stock-space-images.com

already a highly evolved ecosystem that is intimately tied to the climate. But on Mars there is no such ecosystem: chemical and photographic investigations have shown that life is not proliferated and does not control its environment. There may still be dormant organisms, or organisms living underground. As good explorers and scientists, and in compliance with the planetary protection treaty, we should thoroughly explore Mars for extant life before contaminating our science investigations with Earth organisms or causing a competition between Earth and Mars life. Fortuitously, the first stages of terraforming are expected to revert Mars to the way it was in its early history –

when life would have started – thus giving any dormant or struggling survivors a chance to come out of hibernation and recreate a biosphere.

A discussion of terraforming would be incomplete without asking the question ‘Should we?’. Just because terraforming is technologically feasible and would not directly destroy an ecosystem does not necessarily mean that we should do it. Mars is beautiful and interesting the way it is, and perhaps we should leave it this way to allow its study by future generations as well as to preserve its current beauty. I would argue that life is the most valuable and beautiful thing we know, and spreading it throughout our Solar System and beyond is the

most important thing we could do! It is the presence of life that makes Earth unique, and it is this presence of life that allows our own existence. The terraforming of Mars would also allow us to more easily colonise and explore the planet, requiring us only to wear oxygen masks but no space suits in the higher pressure atmosphere.

One hundred years ago, astronomers thought they saw water and vegetation on Mars. They were wrong at the time, but maybe they were just seeing the future.



Locking the cradle

Winfried Weissenhorn's group at the European Molecular Biology Laboratory in Grenoble, France, has uncovered a possible way to tackle a range of dangerous viruses – by trapping them inside their cocoons. **Claire Ainsworth** investigates.



It is perhaps one of the most feared diseases in the world. Once they appear, the classic symptoms – stumbling, drooling, fear of water, paralysis – almost always portend death. Only five people have ever survived the onset of rabies, and all but one suffered permanent neurological damage. Although vaccination and post-exposure preventive treatments have dramatically reduced the impact of the disease in Europe and North America, there is still no cure. Rabies remains a serious threat in many developing nations, killing up to 70 000 people every year.

Worryingly, rabies and similar viruses may now be re-emerging in developed countries, spread to people by contact with bats. So the discovery by Winfried Weissenhorn, Rob Ruigrok and their colleagues of an avenue to attack the virus is very timely. The teams, based at the European Molecular Biology Laboratory in Grenoble, France, and the neighbouring Unit for Virus Host Cell Interactions (UVHCI), have uncovered the structure of the protein that cocoons the virus's genetic material and hides it from the body's immune system until it has a chance to copy itself. It may be possible to use drugs to lock the genome inside this protective cradle, thus preventing viral replication.



Winfried has moved on to the UVHCI hosted in the Carl-Ivar Brändén Building

But the work has implications beyond the realm of the single disease rabies. It turns out that many other viruses, including the Ebola, Borna disease and measles viruses, have similar cocoons for their genomes, meaning that this finding could also shed light on where such viruses came from and how they evolved. The rabies virus, like several other viruses, forms its genome out of a single strand of RNA, a molecule similar to the DNA that carries our genes. But unlike DNA, the information encoded by the virus' RNA cannot be directly used to build the proteins needed to make the virus. Instead, it is a complementary copy, a kind of chemical photographic negative, of the sequence needed. So before the virus can make the proteins that constitute the shell protecting its genome, it first has to convert this 'negative strand' of RNA into 'positive' ones that can be translated into proteins. It also needs to make more copies of its genome to turn into more viruses.

For the virus, these processes are fraught with danger. Mammalian cells, including human cells, contain

defence systems that attack and destroy foreign RNA. So the virus hides its vulnerable genome by packing it tightly inside a nucleocapsid, a shell made of a protein called nucleoprotein, to protect it until it can get inside the cell where it hijacks the host's cellular machinery to replicate and produce viral proteins. As well as shielding the genome, nucleoprotein helps to control the balance between the production of proteins needed for viral replication and the process of replication itself, because both cannot happen simultaneously. In this way the nucleocapsid plays a key role in the virus's life history.

Until now, however, the only clues scientists had about how nucleoproteins worked, came from fuzzy electron microscope images that showed how the nucleoprotein molecules polymerise on the genome to form nucleocapsids, but revealed little about the structure of the protein itself. To find out more, Rob Ruigrok of the UVHCI and Winfried Weissenhorn collaborated to make crystals of nucleoprotein and determine its structure using the high-

intensity X-ray beams available at the European Synchrotron Radiation Facility, also in Grenoble. Crystals are symmetrical structures, and when exposed to X-ray beams they produce a highly ordered diffraction pattern from which scientists can deduce the precise shape of a molecule. By determining the structure of the nucleoprotein, the researchers would be able to start designing the drugs that could lock the viral genome within its protective shell.

The project began in Rob's lab, where his team had been working on the nucleoproteins of a number of negative-strand RNA viruses since the mid-1990s. The rabies virus just happened to be the one that turned out to be the easiest to work with. Aurélie Albertini, a PhD student in the lab, had succeeded in getting insect cells in tissue culture to produce rabies nucleoprotein. The protein wrapped itself around the host cells' RNA molecules, forming rings containing 9 - 13 protein molecules. Rob Ruigrok's group had realised earlier that these behaved as miniature nucleocapsids, and electron microscopy studies pro-

vided coarse insights into their structure, which revealed that they closely resemble the rabies nucleoplasmid and hence could be used to study the structure of nucleoprotein arranged around RNA.

Aurélie started to work on producing nucleoprotein-RNA crystals, a project that was later joined by Amy Wernimont, a postdoc in Winfried's lab. But the molecules were not playing ball, and both Aurélie and Amy struggled for a long time to get crystals that would allow Amy to determine the structure at a resolution of 4 Ångströms, which is sharp enough to distinguish how the protein folds, but not quite enough to show the

sequence of amino acids, the individual building blocks of the protein. One problem was that the cells she was working with only produced tiny amounts of the nucleoprotein.

Fortunately, Josan Márquez's high-throughput crystallisation facility was at hand to help solve the problem, using only small protein samples. "The crystallisation robotics was absolutely wonderful," recalls Winfried. "If we had needed large samples, we would not have been able to screen for the right crystallisation conditions." The team eventually found the right conditions, the precise concentration of the protein and a complex mixture of chemical reagents needed for crystallisation, and managed to tweak them to gain 3.5 Ångström resolution – enough to construct a detailed model of the protein's structure. Help also came from Raimond Ravelli, who assisted with data collection, fine-tuning the X-ray exposure time to get the best results and offering continuous advice at var-

ious stages of the investigation into the protein structure.

The results revealed that the nucleoprotein clamps itself completely around the RNA, locking it away like family jewels in a bank vault. "It's not accessible for any other enzyme to attack it," says Winfried. The protein is formed from two main working parts, or domains. One, called the CTD, cradles one side of the RNA and also sticks to the CTDs of other nucleoprotein molecules, helping to form a helical cocoon. The other domain, the NTD, sits on the other side of the RNA and does not make extensive contact with the other nucleoproteins. The overall structure is like a clamp squeezing around the RNA and keeping everything else out. "The nucleoprotein will prevent the RNA from being recognised by the innate immune system," says Winfried. "But how does it become accessible for replication and translation?"

The answer lies in two stray-thread-like structures that protrude from

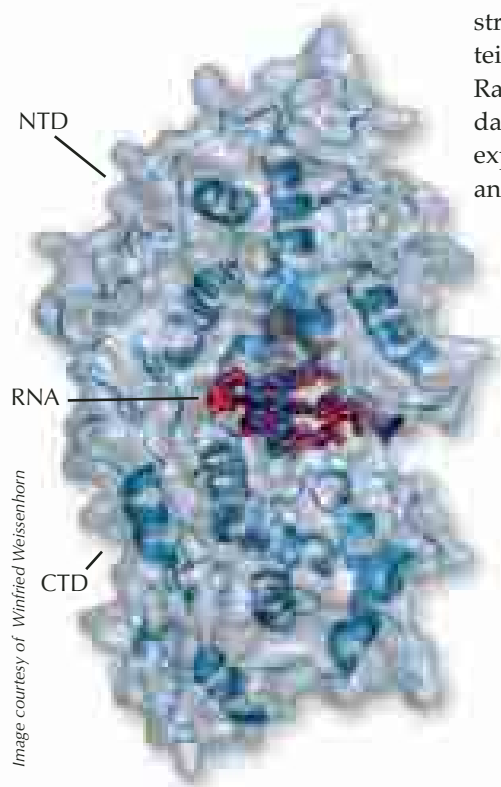

This model of the nucleoprotein reveals that the RNA is completely clamped at the interface of the NTD (top) and the CTD (bottom) and thus is not accessible to degrading host enzymes or the polymerase

Six nucleoproteins (in different colours) bind side-by-side to one RNA molecule (black). The protein is formed from two main working parts: the CTD, which cradles one side of the RNA and also sticks to the CTDs of other nucleoprotein molecules, and the NTD, which sits on the other side of the RNA and does not make extensive contact with the other nucleoproteins

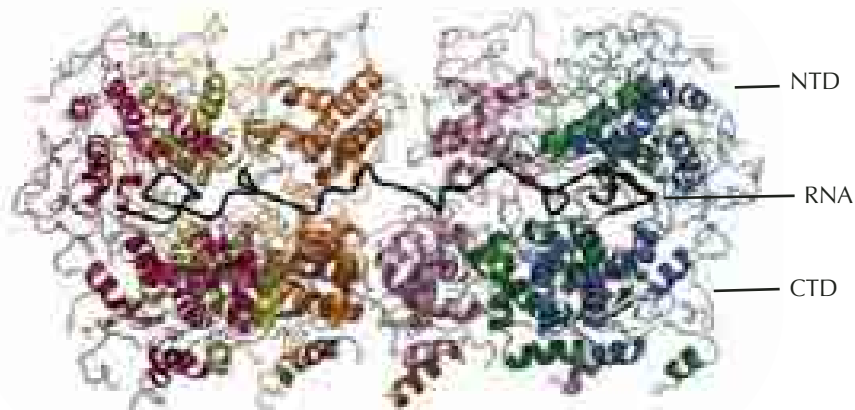

either domain. These could act as hinges, swinging the NTD region up and bending the nucleoprotein clamp open, allowing viral enzymes access to small sections of the genome at a time. One particular protein, called phosphoprotein P, may be involved. It links RNA polymerase, the enzyme needed to copy the genome, to nucleoprotein, and may bind to one of the hinges to swing the NTD out of the way.

This hinge mechanism suggests a way to tackle viruses like the rabies virus with drugs that interfere with it. "If our concept that it opens up is correct, we could jam it shut," says Winfried. "This would block viral replication." Locked inside its protein cradle, the viral genome would be rendered powerless and eventually disposed of by the cell. The next step towards such drugs would be a systematic search for small chemicals with the ability to bind to the hinge region, thereby blocking the opening of the nucleocapsid.

The findings could also give some insight into how negative-strand RNA viruses evolved, says Winfried. Related virus species can have very different genome sequences, making it hard to draw any conclusions about their evolutionary history from sequence comparison alone. Structures, on the other hand, are a different story. The same physical structure can be built from a variety of gene and amino acid sequences. So even if genes evolve and change dramatically, the structures they encode can reveal deep evolutionary links between viruses.

Electron microscopy pictures of RNA molecules of other negative-strand RNA viruses, such as the measles virus, the Marburg virus and a crystal structure of a Borna virus, suggest that their nucleoproteins have a similar hinged clamp structure. This suggests these viruses use a tactic similar to the rabies virus's for shielding their RNA, and so might also be

targeted by drugs that jam their cocoons shut. It also suggests they share a common ancestor, says Winfried. "From the sequence analysis, you wouldn't think they were related," he adds. "I think there was probably some ancestral nucleocapsid, but then they diverged as the viruses evolved to infect different kinds of cells."

Resources

The work described in this article was published as:

Albertini AA, Wernimont AK, Muziol T, Ravelli RB, Clapier CR, Schoehn G, Weissenhorn W, Ruigrok RW (2006) Crystal structure of the rabies virus nucleoprotein-RNA complex. *Science* **313**: 360-363.

Web Resources

To learn more about the work of Winfried Weissenhorn and Rob Ruigrok, see www2.ujf-grenoble.fr/pharmacie/laboratoires/gdrviro/



REVIEW

This article illustrates the nature of scientific research as an ongoing, dynamic entity. As each molecular secret of the life cycle of even the simplest organisms is uncovered by use of sophisticated technologies, there are repercussions for advances in medical treatments and disease control.

Marie Walsh,
Republic of Ireland

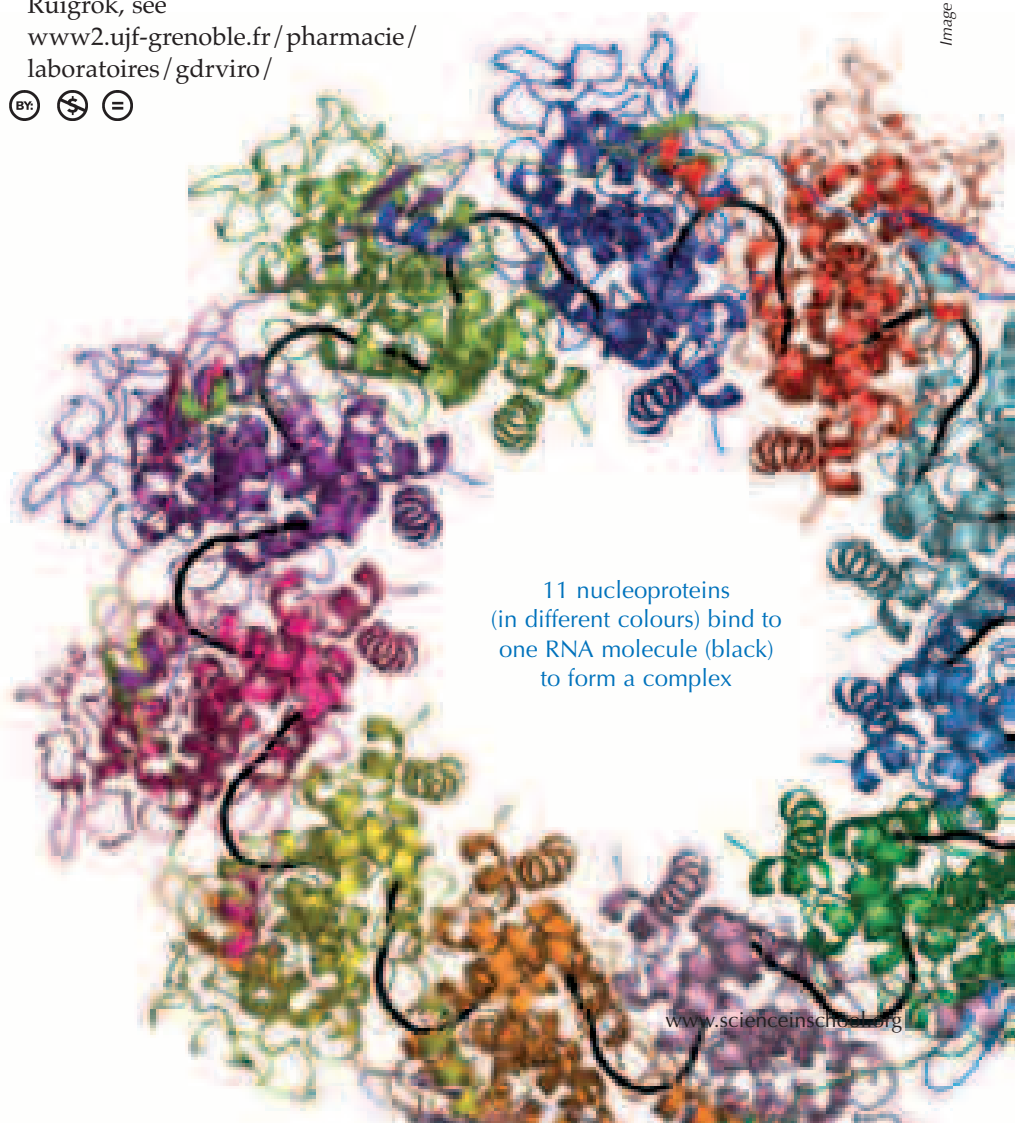

11 nucleoproteins (in different colours) bind to one RNA molecule (black) to form a complex

Image courtesy of Winfried Weissenhorn

Ginger beer: a traditional fermented low-alcohol drink

Because of its low alcohol content, ginger 'beer' is a popular drink with British children. **Dean Madden** from the National Centre for Biotechnology Education, University of Reading, UK, gives his recipe for introducing younger students to the principles of fermentation, food hygiene and the biochemistry of respiration.



Image courtesy of iStockphoto



Image courtesy of John Thomson, Street life in London, 1877

Ginger beer seller, London 1877

The predecessors of modern carbonated soft drinks were often brewed at home. In late 19th century Britain, 'small beers' were fermented drinks with a very low alcohol content. These were usually safer to drink than water, which was often contaminated.

Ginger beer originated in England in the mid-1700s and was exported worldwide. This was made possible by the use of strong earthenware bottles that were sealed by a liquid- and gas-tight glaze (called 'Bristol glaze'). The British Excise Regulations of 1855 required that the drink contained no more than 2% alcohol, and usually it was far less potent: hence ginger beer became popular with children. By the start of the 20th century it was produced commercially in almost

every town in the United Kingdom. The 'beer' was often sold by street hawkers, and it was sometimes dispensed from a 'beer engine' – an elaborate device like an upright piano with beer pump handles that was pulled through the streets by a pony.

In 1935 there were more than 3000 producers of ginger beer in the United Kingdom: today, however, only one British firm makes a traditional brewed product – modern 'ginger beer' is usually made with flavourings and carbonated with pressurised carbon dioxide.

There are many recipes for ginger beer; the basic ingredients are ginger, lemon, sugar and yeast. Real ginger beer is made from fresh root ginger (*Zingiber officinale*), often with other flavourings such as juniper (*Juniperus communis*), liquorice (*Glycyrrhiza*

Compound	Source	Relative strength
Piperine	Black pepper	1
Gingerol	Fresh ginger	0.8
Shogaol	Dried ginger	1.5
Zingerone	Cooked ginger	0.5
Capsaicin	Chilli	150–300



Capsaicin

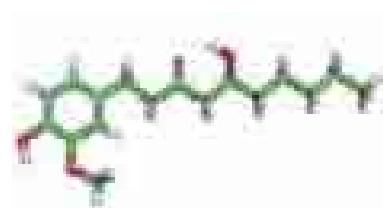

Gingerol

Images courtesy of Pietro Benedetti

Ginger contains the pungent compound gingerol, which is similar in structure to chilli's capsaicin and pepper's piperine. Heating converts gingerol to the less pungent zingerone; drying converts it to shogaol, which is about twice as strong-tasting. It is thought that these compounds evolved as a defence against herbivores as high concentrations are repellent to most mammals.



Equipment and materials

Equipment

- Sharp knife and chopping board
- Lemon zester or grater
- Lemon squeezer
- Rolling pin
- Large spoon
- Kettle for boiling water
- Thermometer
- Large bowl or jug
- Clean tea towel to cover bowl

- Sieve and funnel for straining liquid into bottles
- Plastic (PET) bottle and cap. Do **not** use glass bottles!

Materials

- 1 l water
- 150 g root ginger (~130g when peeled)
- Medium-sized lemon (preferably unwaxed)

glabra) or chilli (*Capsicum annuum*) – which gives the product extra 'bite'. Yarrow (*Achillea millefolium*) is sometimes used to inhibit bacterial growth (as it was in normal beer before the introduction of hops). Jamaican ginger beer is sometimes made with lime instead of lemon juice.

The following recipe is for one litre and can be scaled up and changed as required – some suggest that the ginger should be grated rather than sliced and crushed. Others recommend boiling the mixture before adding the yeast, to extract more flavour from the ingredients.

1

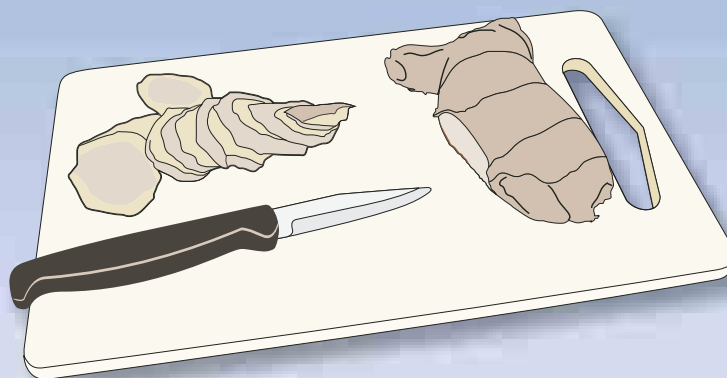

- 140 g sugar (brown or white)
- 4 g cream of tartar (tartaric acid)
- 4 g dried ale or bread yeast, or 8 g fresh
- Sterilising solution suitable for food use
- Strong plastic bag in which to bruise ginger
- Optional: Other spices such as chilli, nutmeg, liquorice, vanilla, cardamom, cloves, juniper, fennel, coriander, star anise

Method

1. Peel the ginger and cut it into slices 3–5 mm thick. Bruise the slices well by placing them in a strong, clean plastic bag and crushing them with a rolling pin.
2. Place the ginger in a large bowl or jug. Scrape the lemon zest over it, then add the juice from the lemon.
3. Place the remaining ingredients except for the yeast in the bowl, then carefully pour on boiling water. Stir.
4. Cover the bowl with a clean cloth and leave the liquid to cool to 25–30 °C (this can take 60–90 min).
5. While the liquid is cooling, sterilise the PET bottles using the sterilising

solution. Ensure that the bottles are thoroughly rinsed with clean water after sterilising.*

6. Add the yeast to the warm liquid in the bowl and stir until it has dispersed.
7. Cover the bowl with a clean cloth and leave it in a warm place for 24 h.
8. Skim off the yeast, leaving the sediment in the bowl. Strain into the sterilised plastic bottles, leaving a 3–5 cm air gap at the top.
9. IMPORTANT! Allow the beer to ferment at room temperature (~21 °C) for *no more* than 48 h, then place the bottles in a fridge. Drink within six days.

* There is no need to use boiled water to rinse the bottles after sterilisation. The sterilising step is to get rid of major contaminants left in reused bottles. The tap water used for rinsing should not introduce contaminants, and should it do so, they will be quickly out-competed by the relatively large inoculum of yeast. The low pH of the liquid (from the lemons) will also prevent bacteria (although not yeast) from growing.

Safety and other concerns

Glass bottles must NEVER be used, as the gas produced will cause them to explode. This drink should always be made in plastic bottles, and it should always be refrigerated and consumed within six days. The short fermentation period and refrigeration ensure that the alcohol content of the drink remains low.

Please remember that some religious groups object even to the consumption of products that contain little or no alcohol but have been produced by brewing. The students may, however, be happy to take part in the practical without drinking the resulting ginger beer. Teachers should be sensitive to such concerns.

Preparation and timing

It takes approximately 90 minutes to prepare the drink, including a cooling period of 60 minutes. The initial fermentation takes 24 hours, followed by up to 48 hours fermentation in bottles. The bottles can be sterilised in advance if desired.

Images courtesy of Dean Madden

2

3

4

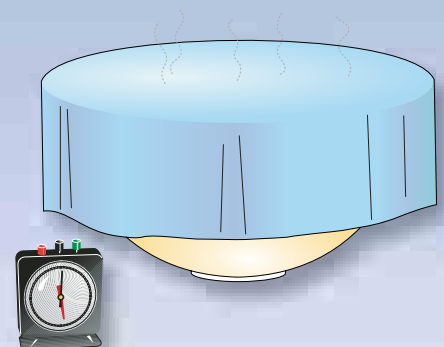
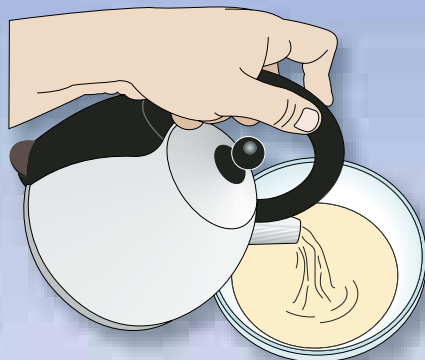
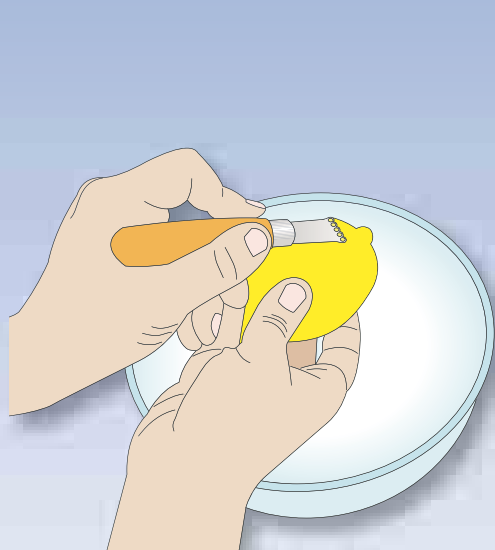

Additional investigations

This practical activity can be used as the starting point for other practical investigations, some of a technological nature. These include:

1. Most fermented soft drinks are acidified to inhibit bacterial growth. Does this also inhibit the yeast? Investigate the effect of pH on the rate of fermentation (12 g of citric acid is roughly equivalent to adding the juice of one lemon).
2. Some flavourings, such as cinnamon, cloves and yarrow, are thought to inhibit the growth of microbes. Devise an experiment to test this. What are the implications of your findings for the recipes and methods of soft-drink production?
3. In the USA, sachets of dried herbs and spices were sold so that people could make 'root beers' at home. Could similar kits be devised for ginger beer? How could you prepare and package the ingredients so that they were convenient for home users?
4. How could you measure and control the alcohol content of a fermented drink, to ensure that it was not excessive?

5. Homemade ginger beer contains live yeast. Consequently, it has a short shelf life and there is a danger that the bottles might explode. Investigate ways of overcoming this problem. These might include one or more of the following:

- Selling the product as a fresh drink that has to be stored under refrigeration
- Filtering the yeast from the drink before bottling it
- Precipitating the yeast with a fining agent before bottling
- Pasteurising the drink before bottling, to kill the yeast
- Adding a chemical preservative to the drink to kill the yeast
- Using a type of yeast that precipitates (floculates) naturally
- Increasing the sugar content of the finished drink so that the yeast cannot grow (due to osmosis)
- Designing a special bottle that allows excess gas to escape while maintaining the fizz and preventing contamination of the drink.

Suppliers

All of the materials required to make ginger beer can be bought from a supermarket, market or a supplier of wine-making equipment.

Note, however, that ginger beer was traditionally made not with pure yeast, but with a mixed culture of lactobacilli and yeasts that is sometimes called a 'Ginger beer plant' or a 'Beeswine' culture. This is similar to a kefir culture and can be maintained and passed on to others who wish to make ginger beer.

The 'ginger beer plant' was described in:

Ward HM (1892) The ginger beer plant and the organisms composing it. *Philosophical Transactions of the Royal Society of London. B* **183**: 125–197

According to the UK National Collection of Yeast Cultures (www.ncyc.co.uk/beeswine.php), the only safe commercial source of this culture in Europe is now the German culture collection, DSMZ. They have a special education price for this culture, DSMZ No. 2484 (www.dsmz.de/microorganisms/html/strains/strain.dsm002484.html).

Images courtesy of Dean Madden

5



6



Resources

For an excellent recipe book for non-alcoholic fermented drinks, see:

Cresswell SE (1998) *Homemade root beer, soda, and pop*. Pownal, VT, USA: Storey Books

It includes hints on bottling, cleanliness and the production of concentrates from raw ingredients.

A large, world-renowned and authoritative text on all aspects of food culture and chemistry is:

McGee H (2004) *On food and cooking, 2nd ed.* London, UK: Hodder and Stoughton

For Wikipedia’s webpage on ginger beer, see:

http://en.wikipedia.org/wiki/Ginger_beer

For the Yahoo! group webpage on ginger beer plants, see:

<http://health.groups.yahoo.com/group/GingerBeerPlant/>



REVIEW

When I was at school there always seemed to be some lad with a ginger beer plant in his desk – woe betide him if it exploded! This interesting and excellent article describes how ginger beer can be made simply without a ginger beer plant, using everyday items.

The practical can be used to complement different levels of scientific understanding from basic sterility to fermentation, respiration, microbial growth and the effect of pH on microbial growth. The additional investigations suggested in the article would make excellent individual projects for students aged 16-18 or group projects for younger students. Students could be encouraged to make a small poster on the antimicrobial activity of a spice as well as investigating it practically. More advanced students could investigate chilli strength and the chemical components of capsaicin. The wide range of activities this practical offers means that it could be used several times with both the same and different groups of students.

Shelley Goodman, UK



7

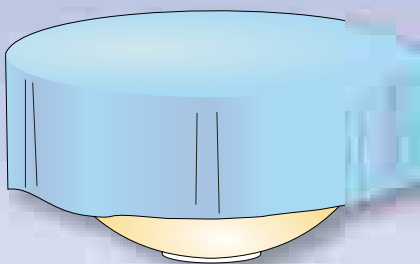

8

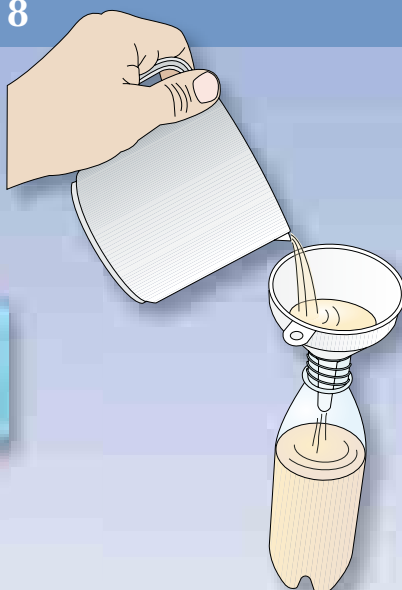

9

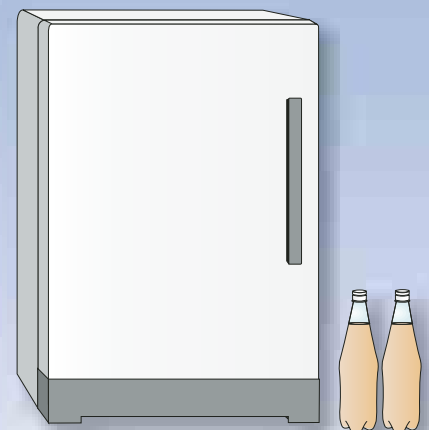

Chewing flavours

Ken Gadd and **Luca Szalay** introduce a procedure used in industry – and adapted for school students – to measure the citric acid level in chewing gum.

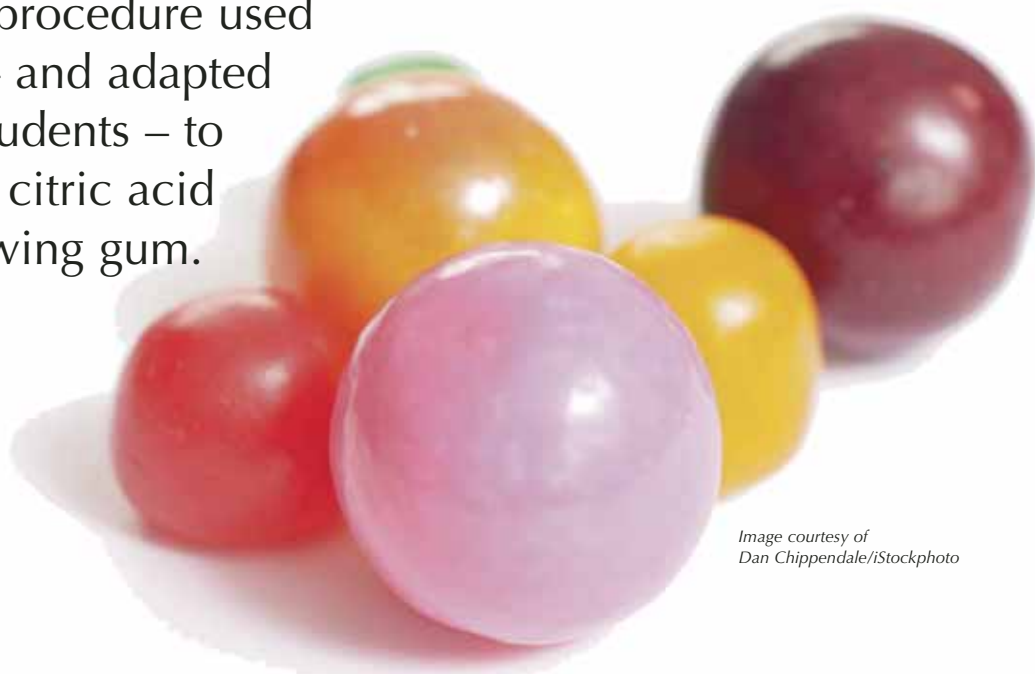

Image courtesy of Dan Chippendale/iStockphoto



The StandardBase project

The StandardBase project has produced 72 standard analytical procedures, used in industry and adapted for use by students in schools and colleges, accessible via the Internet. For more information about the project, see 'StandardBase: a Leonardo da Vinci pilot project for practical education and training in chemistry' in this issue of *Science in School*.

BACKGROUND

How acidic is chewing gum?

How many people do you know who chew gum? Why do they? You could try a straw poll, but the most likely answer will be for the flavour. Chewing gum consists of a water-insoluble gum base and water-soluble ingredients such as flavourings and sweeteners. When you chew it, the flavourings and sweeteners are released, dissolved and swallowed (hopefully the gum stays in the mouth). Once the flavour has been extracted, the gum is discarded. Unfortunately it sticks strongly to hard surfaces such as concrete and is very hard to remove. There's plenty of evidence for this if you look at the pavements you walk on. But back to flavouring....

A common ingredient in chewing gum and other confectionary is citric acid. It gives that sharp, refreshing citrus taste that 'attacks' the tongue. The packaging will tell you how much

citric acid is in the chewing gum. It's the role of an analytical chemist in the quality control laboratory to check it out. The method below is based on the standard procedure used by a company that manufactures various flavours of chewing gum and bubble gum (a type of chewing gum). It has been adapted for use in schools and colleges so that your students can mimic authentic workplace practice.

Here are some questions that could be used to get students thinking:

- How many people do you know who chew gum?
- How old are they?
- What makes bubble gum different from other types of chewing gum?
- How do you remove chewing gum from clothing?
- Why do sugar-free gums still taste sweet?
- How could you work out how much acid is in chewing gum?

The procedure: Determination of citric acid in Hubba Bubba® chewing gum using acid-base titration

Duration	1 hour
Analytical instruments used	Volumetric glassware
Sample specification	Orange flavoured Hubba Bubba® bubble gum
Supplied by	Most confectionary shops and supermarkets
Component to be determined	citric acid
Method(s)	titrimetry acid-base
Field(s)	food and beverages

Before they start the practical, teachers may want their students to understand the chemistry of the analysis. To check they have an appropriate knowledge, students might try the interactive test on the StandardBase website^{w1}. To help their work, students can also download a file about titration^{w2}.

Scope

The aim of this analytical procedure is to determine the citric acid content in Hubba Bubba® bubble gum. This bubble gum is available in the UK and most parts of Europe. It is manufactured by Wrigley^{w3} in Plymouth, UK. The method described here is based on an analytical procedure used by Wrigley in their Plymouth laboratories.

Principle

The determination is based on an acid/base reaction between the citric acid in the bubble gum and standard sodium hydroxide. The citric acid content of the bubble gum can be calculated from titration results.

Equipment

- Kitchen pastry roller (rolling pin)
- 250 cm³ conical flask
- 250 cm³ graduated flask
- 100 cm³ graduated flask

- Magnetic stirrer and follower (also known as a flea)
- 10 cm³ burette (reading to nearest 0.02 cm³)
- Top pan analytical balance
- Wood block
- Knife/scissors

Materials and their CAS numbers^{w4}

- Orange flavoured Hubba Bubba®
- Sodium hydroxide (CAS number: 1310-73-2)
- Phenolphthalein (CAS number: 77-09-8)

Reagent solutions

- Standard 0.10 mol dm⁻³ sodium hydroxide. If this is not available, dissolve 1.00 g of sodium hydroxide in about 100 cm³ of pure water. Wash carefully to a 250 cm³ graduated flask and make up to the graduation mark. Homogenise the solution. Standardise by titration with 0.10 mol dm⁻³ hydrochloric acid, itself standardised against solid potassium hydrogencarbonate.
- Phenolphthalein indicator. Weigh out 0.20 g of phenolphthalein and dissolve in about 50 cm³ of methanol. Transfer solution to a 100 cm³ graduated flask, make up to the graduation mark with methanol and homogenise the solution.

Procedure

1. Take one orange flavoured Hubba Bubba® bubble gum piece, unwrap it and place onto a wood block.
2. With the rolling pin, roll the bubble gum into a very thin strip approximately 160 × 30 × 0.5 mm.
3. Cut the thin strip into small pieces about the size of long grain of rice.
4. Weigh out 1.00 g of orange flavour Hubba Bubba® bubble gum bits.
5. Add to 100 cm³ of pure water contained in a 250 cm³ conical flask. Add a magnetic follower and stopper.
6. Stir vigorously for 30 min, making sure bubble gum bits do not lump together.
7. Add 0.50 cm³ of phenolphthalein indicator and titrate with **0.10 mol dm⁻³** sodium hydroxide contained in a 10 cm³ burette. The end point is pink.
8. Repeat twice more and average the three results. Average titration = V cm³.

Calculations

Use the following to calculate the percentage by mass of citric acid monohydrate in the Hubba Bubba® bubble gum:

- Each cubic centimetre of **0.10 mol dm⁻³** sodium hydroxide is equivalent to 7.00 mg of citric acid monohydrate.
- % by mass citric acid monohydrate = $0.70V$



Note: a correction factor is necessary if the sodium hydroxide solution is not exactly 0.10 mol dm^{-3} .

Expression of results

Give the mass of citric acid monohydrate in Hubba Bubba® bubble gum in percentage by mass (mass of citric acid monohydrate in 100 g of bubble gum). The manufacturer's allowed range is 1.9–2.1 percentage by mass.

Precision

The precision of the analysis is determined by the burette readings. An inexperienced student might read a burette to a precision of $\pm 0.05 \text{ cm}^3$. More experienced students might read to $\pm 0.02 \text{ cm}^3$.

The graph

The graph below shows the results obtained by students in other European countries (accurate at time of going to press). If your students are interested in finding out the latest status, they can view the most up-to-date results online^{w5}.

If your students want to add their own results to the graph, email Luca Szalay (luca@chem.elte.hu). You will get a username and password to be able to use this function of the StandardBase database. Then you can register your students, which will allow them to upload their numbers on the graph.

Web references

- w1 – Teachers may like to get their students to try the interactive test on the StandardBase website: www.vapro-ovp.com/applications/toetsing/vraag.asp?toetsID=29
- w2 – A file about titration can be downloaded from the StandardBase website: www.wrigley.co.uk/index.cfm?articleid=138
- w3 – For more information about Hubba Bubba® products see www.wrigley.co.uk/HubbaBubba/Index.cfm
- w4 – The CAS Registry is the largest and most current database of chemical substance information in the world. See www.cas.org/expertise/cascontent/registry/regsys.html

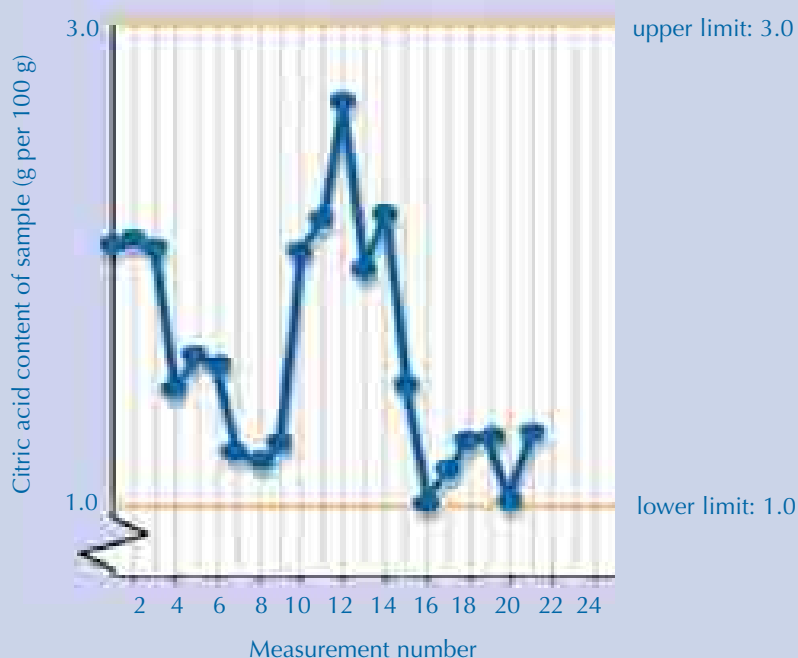

Image courtesy of Dan Chippendale/iStockphoto

w5 – A graph of previous results of this analysis can be viewed and downloaded here:
<http://standardbase.live.ism.nl/sbase/maindetails.asp?expid=3362#>

Resources

This and other protocols can be downloaded from the StandardBase database:
<http://standardbase.live.ism.nl>.
 Click on 'View or conduct a StandardBase procedure' then 'View all experiments'. Then select the protocol you would like to view.

Ken Gadd works for 4science, UK, and Luca Szalay is based in the Institute of Chemistry at Eötvös Loránd University, Hungary.

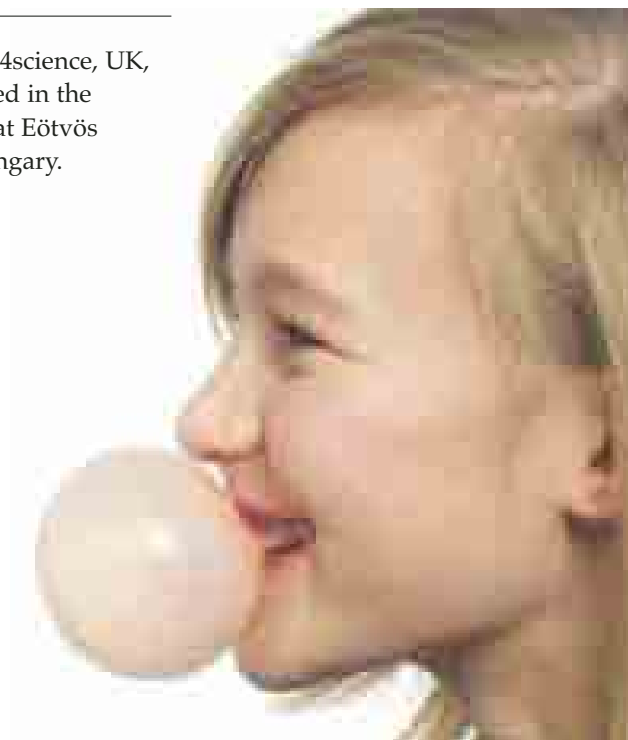

Images courtesy of Stockphoto



This article offers an interesting and original approach to acid-base reactions and acid-base titrimetry, two topics usually regarded as heavy and boring (remember when you were a student?).

Starting from a familiar object (chewing gum), with its characteristics and practical problems, the authors present the analytical procedure (determination of citric acid in Hubba Bubba® chewing gum), widening the subject to theoretical aspects with the help of web references. Chemistry teachers could use the article to discuss the importance of standard analytical procedures, in addition to the topics of acid-base reactions and acid-base titrimetry. The proposed analysis gives the opportunity for the mathematical treatment and sharing of the obtained data, thus linking chemistry, statistics and the English language.

The link to a real job in a quality control laboratory, the richness of didactic materials in the StandardBase website (preliminary tests, theory, graphs and protocols) make 'Chewing flavours' a useful resource for chemistry teachers and students. It could be used to discuss the role of the analytical chemist in the context of industry and research and / or to prepare a visit to a factory or to a laboratory.

The article could be useful in upper secondary or vocational schools in Italy not only to test the pro-

posed activity but also the other procedures of StandardBase project that are available on the website. The possibility to join the project is another interesting feature of the article.

Teachers may like to pose the following comprehension questions:

The substance that gives orange Hubba Bubba® its flavour is:

- malic acid
- citric acid
- ascorbic acid
- hydrochloric acid

The concentration of the titrating solution used in the procedure is:

- 0.10 g dm⁻³
- 1.00 % by mass
- 0.10 mol dm⁻³
- 1.00 mol dm⁻³

Following the authors' suggestion, I would find a sequel on the chemical aspects of removing chewing gum from surfaces and clothes interesting.

Giulia Realdon, Italy

Bring the fascination of the science centre into the classroom

Amito Haarhuis from the Science Center NEMO in Amsterdam, the Netherlands, describes a project that challenges pupils aged 11-12 to design and create their own exhibits.

Children acquire technical skills by building the exhibit 'The Magic Soap Curtain'

Image courtesy of NEMO

During the Science Center at School project, pupils build their own exhibits, similar to those in a science centre – with the help of an employee at a real science centre. Using their exhibits, the pupils set up a science centre in their own school. They present the results of their research into the science behind their exhibits and invite fellow pupils and parents to try them out.

The project in a nutshell

Science Center at School consists of eight mornings or afternoons, spread over at least five weeks. Only the first half-day takes place at a science centre. Here, a science centre employee introduces the project, telling the children what an exhibit is and what they have to think about when they build their own exhibit.

The rest of the project takes place at school. The pupils work in pairs and choose (from a list provided by the science centre) which of more than 20 exhibits they want to build. They then make a technical drawing of their chosen exhibit, thinking about how they are going to make it and how big it should be. The children would like

Image courtesy of NEMO



Making a technical drawing helps students to work in a more organised way



BACKGROUND

Help is at hand

If you are interested in this project and would like more information, Science Center NEMO would be happy to help. Contact Amito Haarhuis (haarhuis@e-NEMO.nl).

nothing better than to get down to building the exhibit right away; making a technical drawing slows down this process. It does, however, help the children to work in a more organised way and think before they act.

From their technical drawing and a description provided by the science centre, they then build the exhibit. All descriptions and building instructions can be downloaded from the *Science Center at School* website^{w1}. Building the exhibits involves sawing, drilling, cutting and pasting. For this part of the project, extra hands are needed in the classroom: two extra people (parents, trainee teachers or colleagues, for example) should be sufficient.

After they have finished building, the pupils do some research using their exhibit. They study how it works and what scientific phenomenon it demonstrates. Using posters and oral presentations, the pupils then present their research to their classmates, teachers, family and friends, who have the chance to try out the exhibits too.

The main objectives of this project are to encourage an enquiring attitude to science and technology, and to demonstrate to the pupils how they can work together, give presentations (written and oral) and acquire a high level of technical skills.

Successful pilot

The pilot project was carried out in ten primary schools, and pupils rated the project with an average score of 8.5 (on a scale of 0-10.0). The most highly valued part was the building of the exhibits (9.4). The reasons given by the children for the high score were: “because you don’t often get to do things such as sawing; I like that kind of thing” and “once it’s finished – you can see if it works”. Showing the exhibits to other children and parents was also rated highly (8.7): “because you’re happy with what you’ve made and you can show it to other people” and “because some people just couldn’t believe it and were thinking ‘how do they do that?’”.



Image courtesy of NEMO

A science centre at school

Girls became more technical

What was striking was the fact that most of the girls considered themselves ‘not really technical’ before the project, whereas most of the boys considered themselves ‘pretty technical’. After the project, the children considered themselves on average more technical than before: 7% more children regarded themselves as ‘pretty technical’ or ‘very technical’.

Question for the girls: Do you consider yourself technical?

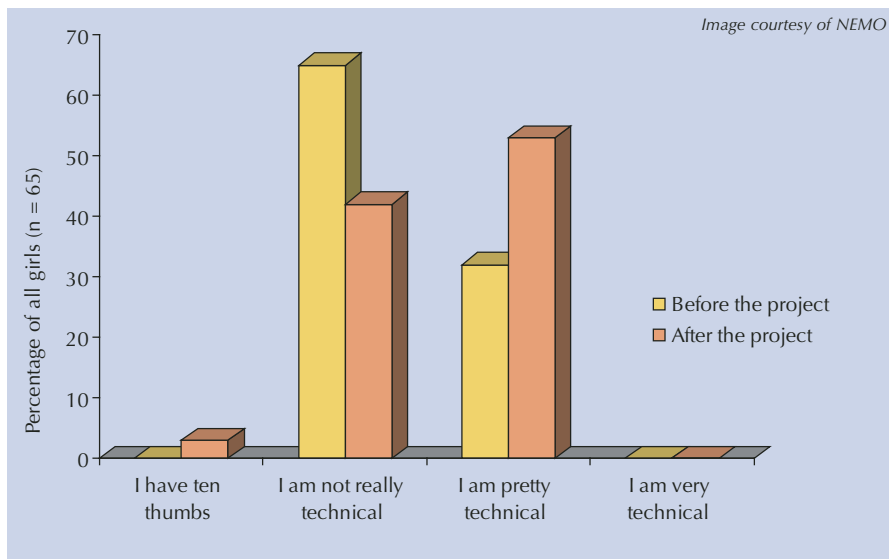

More significant is the increase among the girls: after the project, the number of girls who regarded themselves as 'pretty technical' rose by 66% and the number who considered themselves as 'not really technical' fell by 35%. It seems that the boys generally overestimated their own abilities before the project. By doing the project they got a more realistic self-image. Girls had a more realistic self-image to start with, but generally had less experience with technical activities. By taking part in the project they discovered that they were actually quite good at it, and that it was fun!

Educational trajectory

The project is connected with an educational trajectory for enquiry-based learning and learning by design that NEMO has developed in co-operation with the AMSTEL Institute of the University of Amsterdam.

We distinguished a 'science trajectory', to which enquiry-based learning is central (didactics of natural sciences), and a 'technology trajectory', to which learning by design is central (didactics of technology). An important aspect of both didactics is that it

is the process and not the end product that is most important. Therefore, guidance by the teacher focuses primarily on acquiring an investigative attitude and technical skills. The Science Center NEMO provides a training session for teachers to prepare for the project.

Enquiry-based learning

It is important to realise that enquiry-based learning begins only once the exhibit has been built: the finished exhibit makes a physical phenomenon or technical principle tangible, so the exhibits lend themselves well to follow-up research.

The children go through three research phases: first, 'fooling around' with the exhibit (unfocused investigation), which gives rise to lots of questions; second, 'focused experimentation', where specific research questions are included in the lesson descriptions and children can discover answers themselves; and third, 'theoretical research', where pupils research using books and the Internet to learn about the science behind how the exhibit works and how those scientific principles apply in daily life.

Learning by design

The lesson description explains how to design the exhibit, as well as the materials and tools required. However, no quantities for materials are given. Before the pupils can establish how much of each material they need, they must decide how big their exhibit will be. Once they have decided this, they sketch a 1:2 scale technical drawing, indicating how the components should be attached to each other.

The children present their technical drawings to each other and their teacher, asking for feedback. They use this feedback to improve their technical drawing.



Science Center at School is a project of the National Science and Technology Center, the umbrella organisation of Science Center NEMO, the largest science centre in the Netherlands. The National Science and Technology Center is working with the AMSTEL Institute of the University of Amsterdam, the Netherlands National Institute for Curriculum Development (SLO) and ten primary schools.

The project was financed by the European Union under PENCIL (Permanent European resource Center for Informal Learning) project. Under this banner, 14 European science centres and museums worked with schools and universities to try to find new ways of shaping science education.

BACKGROUND



Examples of exhibits



This exhibit shows a zoetrope, a kind of forerunner of the modern film, developed at the end of the 19th century. From this exhibit, pupils learn something about the phenomenon of light (physics), the working of the eye and brain (biology), and technology (it is a technical product).

Images courtesy of NEMO



This exhibit is a special mirror consisting of loose strips with slots in between them. By placing someone in front of the mirror and someone behind – and having them look at each other in the mirror – together they can make a new face which is a mixture. This exhibit is about light and reflection (physics), and is also a technical product.

BACKGROUND

Instructions for these and many other exhibits can be downloaded from the Science Center at School website^{w1}.

Most of the time, the exhibits do not work straight away. It is important that the teacher regards the technical problems that the children encounter as novel learning opportunities. Often the teacher will be tempted to think up solutions to help the children. But according to the didactics of learning by design, it is important that children come up with inventive solutions themselves. They can test whether these work immediately and tell the teacher the result.

the English-language lesson materials for this project, click on 'Primary Education – Teachers' and then 'Lesson materials':
www.sciencecenterschool.nl/index.php?id=95

Amito Haarhuis is the Head of Education at the Science Center NEMO in Amsterdam, the Netherlands.



Web references

w1 – More information about the project is available on the *Science Center at School* website. To see all

EUROPE'S LARGEST CLASSROOM

SCIENCE ON STAGE FESTIVAL BERLIN 2008:
THE EUROPEAN VIP-LOUNGE FOR YOUR SCIENCE TEACHING IDEAS

APPLY
NOW!

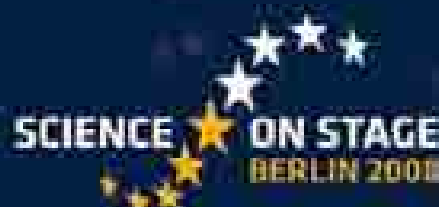

For the first national Science on Stage Festival [23rd - 26th October 2008],
in the Urania in Berlin Science on Stage Deutschland e.V. and THINK ING, are
looking for teachers with extraordinary ideas for teaching science.
We provide: Concepts, materials and a lively exchange with colleagues
from all over Europe. **Closing date for applications: 25th May 2008**

www.science-on-stage.de

SCIENCE TEACHING FESTIVAL

BERLIN, 23RD-26TH OCTOBER 2008

Science teachers are invited to submit their application for participation in the Science on Stage Festival to the association Science on Stage Deutschland e.V. (SoSStD) by 25th May 2008.



APPLICATION CATEGORIES:

1. Exhibition - Fair
2. Workshops
3. On-stage activities
(Presentation or performance)

Please send your submission to one of the specified categories and not to all of them or to the general theme.

1. EXHIBITION - FAIR

The exhibition is planned like an education fair. Pedagogues present their classroom concepts and experiments at the themed stands.

Scope of application: Completion of the application form (max. 3 pages) & the template on the SoSStD homepage.

2. WORKSHOPS

The workshops provide the opportunity to introduce own teaching methods, develop materials or discuss pedagogical questions. As the leader of the workshop, you get the opportunity to develop or initiate a concept with other actively involved European colleagues which may continue after the festival.

Scope of application: Completion of the application form, together with an agenda (max. 3 pages) & the template on the SoSStD homepage.

3. ON-STAGE ACTIVITIES

Presentations and performances:

3.1. Presentation

Do you know an interesting teaching method or an exciting idea for the classroom that you would like to present to a receptive audience? Would you like to discuss a special scientific topic or give a primer lesson about a particular experiment?

Scope of application: Completion of the application form (max. 3 pages) & the template on the SoSStD homepage.

3.2. Performance

To present science "on stage" also involves play acting. The idea is to present science topics in on-stage performances (45-60 minutes). The performances may range from professionally arranged on-stage performances to student performances and presentations of experiments.

Scope of application: Completion of the application form & the template on the SoSStD homepage (max. 3 pages) + submission of a DVD with the proposed performance (three copies).

GUIDING THEMES

- Science in kindergarten and primary school
- Interdisciplinary teaching
- "Hands on" experiment to boost motivation and cognition
- Self-perception in the teaching process
- Benefits of non-formal education initiatives
- Self-entertainment or moderator? The science teacher of the future

The festival is under the patronage of the Representative of the European Commission in Germany. It is sponsored by TÜRK HSK, the Federal Ministry of Education and Research, the Technology Foundation Berlin and the Seneca AG. The youth project E1 (European organisations) (E1Network) provides non-material support for the festival. The conference venue is the Quadra in Berlin.

APPLICATION AND FURTHER INFORMATION

Science on Stage Deutschland e.V.
Tel.: +49 (0)30 - 46 00 57 - 40
info@science-on-stage.de
www.science-on-stage.de

StandardBase: a Leonardo da Vinci pilot project for practical education and training in chemistry

Image courtesy of the StandardBase project team

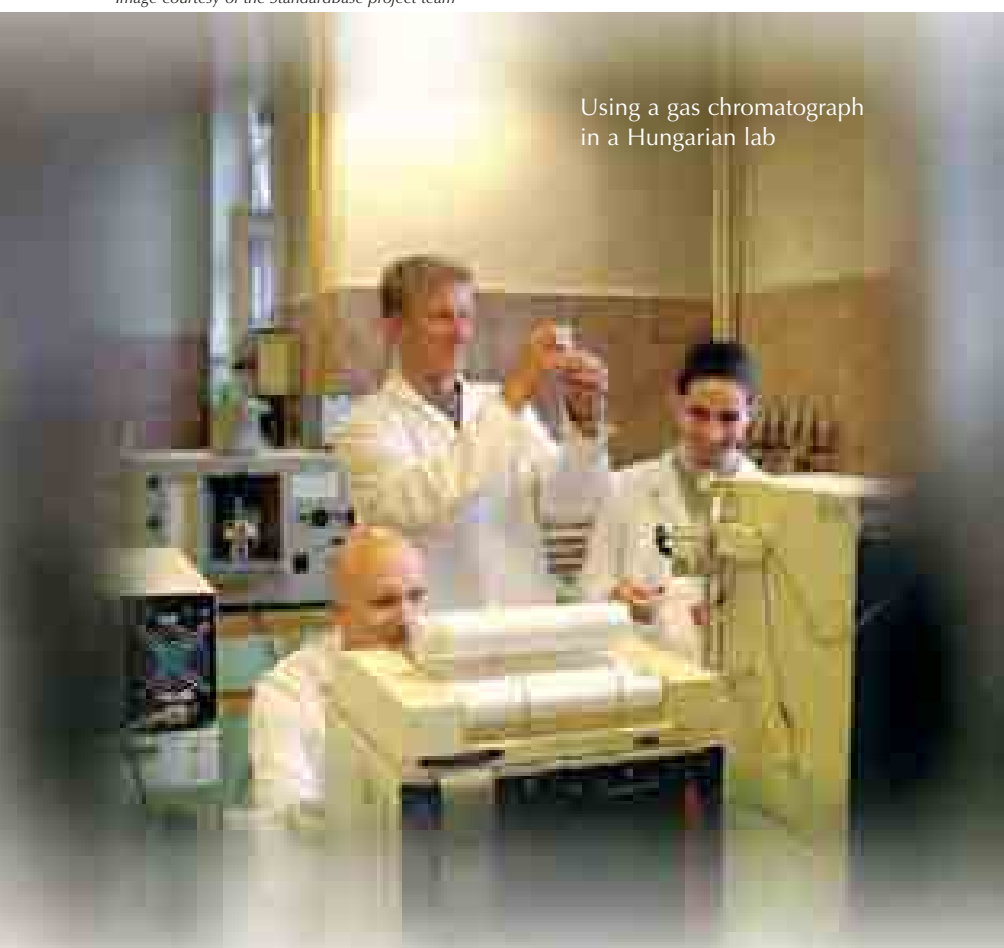

Using a gas chromatograph in a Hungarian lab

The StandardBase project has produced 72 standard analytical procedures used in industry and adapted for use by students in schools and colleges via the Internet. **Ken Gadd** and **Luca Szalay** explain the goals and the use of StandardBase products.

The aims of the StandardBase project – quality matters

How can you be sure your Coca Cola® doesn't contain too much caffeine, your wine doesn't have too much sulphur dioxide or the water you drink won't harm you? It's not

likely that many people will know how to check these things. Instead, we rely on qualified analytical scientists to tell us.

Quality control in the manufacture of chemicals and products such as food, beverages and pharmaceuticals

is vital. Standard analytical procedures are used to ensure quality standards are met. Analytical chemists employed in industry and the public service sector must be suitably qualified and have the skills, knowledge and experience to do their jobs well.



How to access the procedures and activities

BACKGROUND

To download a StandardBase procedure, go to the StandardBase website^{w6} and click on the following links in order: 'Enter procedures database', 'View or conduct a StandardBase procedure', and 'View all experiments'. Now you can choose an experiment from the list by clicking on its title, and the description of the experiment can be downloaded in PDF format by clicking on the link 'Show step-by-step' on the left-hand side of the page. Alternatively, you can find a procedure suitable for certain purposes by choosing among or typing in keywords (e.g. 'Vitamin C') once you click on the 'View and conduct an experiment' link.

The ProBase website^{w9} is under construction and will be ready by the end of 2008.

This includes being able to use standard analytical procedures.

These procedures may be local (used by specific companies), national or international. Many standards are now international, such as the International Organization for Standardization (ISO) standards. Scientists increasingly work with colleagues in other European countries and beyond. The StandardBase project was rooted in the belief that it would be beneficial to teach some common aspects of analytical procedures across vocational schools and colleges in Europe.

However, industrial standard analytical procedures often cannot be carried out in schools because of a lack of specialist equipment, chemicals, expertise and time. The StandardBase project set out to make industrial standard analytical procedures accessible to students in schools and colleges. Procedures were adapted for use in these locations, piloted, revised and added to the StandardBase website for people to use. In addition, a facility is provided for students to share and compare their results with students in other institutions and countries.

Image courtesy of the StandardBase project team



Slovenian students performing a StandardBase procedure

Teachers involved in the piloting of the project found that the motivation aspect was significant. Putting the science into real-life situations interests and engages students. Measuring the alcohol content of a bottle of beer, for example, is more meaningful and relevant to students than measuring its concentration in a mixture prepared by the teacher.

Methodology and outcomes of the StandardBase project

Colleagues associated with four of the partner institutions (Petrik Vocational School in Hungary^{w1}, Drenthe College in the Netherlands^{w2}, Institute 'Jozef Stefan' in Slovenia^{w3}

and 4science in the UK^{w4}) developed and trialled 18 standard procedures each, giving a total of 72. Each institution, together with Eötvös Loránd University in Hungary^{w5}, tried out the procedures developed by the others. The modified procedures and results were put on the StandardBase website^{w6}.

Analyses fell into two categories:

1. Commercially available products
Colleagues in each institution analysed the same branded commercially available product, e.g. toothpaste, aspirin and other pharmaceutical products, cola, petrol and bubble gum (specific details are available on the StandardBase website). This allowed a direct comparison. In effect, school laboratories could participate in a 'laboratory proficiency test'.
2. Environmental studies
Colleagues in each institution analysed environmental samples taken from their own locality, e.g. air and water. Students would not expect to get the same results as one another. However, they could look for trends and patterns in data collected from different locations.

In addition to the procedures, tests were written so that students could check their own understanding. The final stage was for students in each country to try out the procedures. While this work was in progress, VaPro^{w7}, in the Netherlands, and Eötvös Loránd University developed the StandardBase website.

The website is now complete and students may: download procedures; download tests to check their understanding; compare their data with other students' results; add their own results to the database; learn more about the techniques and underpinning principles; and ask questions with the help of the discussion forum and email facilities.

The StandardBase project aims to make the learning process student-

centred. Information and exchange of ideas and data come primarily from the internet rather than the teacher. This helps to develop some of the professional skills needed by practising scientists. The role of the teacher may be limited to organising and supervising the practical work.

Brief summaries of a few StandardBase procedures

Determination of citric acid in Hubba-Bubba chewing gum using acid-base titration

The aim of this analytical procedure is to determine the citric acid content in Hubba Bubba bubble gum. This bubble gum is available in the UK and most parts of Europe. The method described is based on an analytical procedure used by the Wrigley company in their laboratories in Plymouth, UK.

A detailed description of the procedure is published in this issue of *Science in School*⁷⁸.

Determination of fluoride ion content of toothpaste using potentiometry

Fluoride is added to drinking water and toothpaste to inhibit dental caries; it is also present in effluents from many industrial processes, e.g.



The Leonardo da Vinci programme

The StandardBase project was, and the ProBase project is, carried out in response to the goals of the Leonardo da Vinci programme and with the help of the Leonardo funds.

The Leonardo da Vinci programme contributes to the implementation of a vocational training policy for the European Union, which supports and supplements the actions of the member states (article 150 of the treaty establishing the European Community). The council decision states the need to raise the quality, innovation and European dimension of vocational training systems and practices, by means of transnational co-operation.

(Source: The Leonardo da Vinci Programme's *Call for proposals*)

BACKGROUND

the manufacture of fluoro-polymers. In this analysis, a solid state ion selective electrode (ISE) is used to measure the potential of a fluoridated toothpaste sample (or fluoridated water sample).

Determination of zinc in multivitamin tablets using stripping voltammetry

In the pharmaceutical industry, it is often necessary to determine the presence of metals in very small amounts, e.g. trace elements in multivitamin

tablets. This method is applicable for the determination of zinc in the concentration range of 10-200 $\mu\text{g}/\text{dm}^3$.

Coming next: Problem-based activities for vocational science education

Students in schools and colleges of vocational education and training often follow established practical procedures. For example, they might determine the nitrate or phosphate concentration in a solution. Putting these analyses into the context of a real problem – Why is this lake water green? – illustrates their relevance and usefulness. To develop broader professional skills as well as analytical techniques, students might work within a number of constraints, e.g. limited time, budget and resources. Several analytical procedures might be provided, with students deciding which is most suitable for this situation.

So, the analytical techniques and underlying theory remain, but students are also challenged to use them in a situation that imitates authentic workplace practice. Therefore the ProBase project team (formed by the same partners who took part in the



A graph including the results of the determination of the iron content in mosskiller

The main page of the StandardBase website



Image courtesy of the StandardBase project team



Titration in a Dutch laboratory

StandardBase project) wants to develop a range of activities to show not just how science works, but how scientists work. In this project, students use scientific knowledge to tackle problems. They (a) work in teams, (b) manage their time, workload and resources, and (c) communicate with one another and with non-scientists. These are the essential skills used by practising scientists.

We hope that more and more schools and colleges will make use of and contribute to the StandardBase and ProBase databases in the coming years.



The article on the Standard Base project gives the reader a view of the dynamic world of vocational education and of the potentialities offered by European transnational programmes in this specific field.

With a plain style the authors highlight the main features of the project, leaving the rest to the project's website, which is very rich in analytical procedures and other didactical materials. StandardBase's winning ideas are the international standardisation of protocols, the quality assessment through laboratory proficiency tests, the real-life experiences and e-learning-based methodology.

The article could be used to raise the interest of secondary-school students by challenging their skills using the proposed activities. In addition, the StandardBase website allows students and teachers to exchange information and compare results, adding a European dimension to the learning process.

REVIEW

Giulia Realdon, Italy

Web references

- w1 – Petrik Vocational School, Hungary: www.petrikl.sulinet.hu
- w2 – Drenthe College Unit Techniek, the Netherlands: www.drenthecollege.nl
- w3 – Institute 'Jozef Stefan', Slovenia: www.ijs.si/ijs.html
- w4 – 4science, United Kingdom: www.4science.org.uk
- w5 – Eötvös Loránd University, Hungary: www.elte.hu
- w6 – The StandardBase website: www.standardbase.com
- w7 – VaPro, the Netherlands: www.vapro.nl
- w8 – For a full description of the chewing gum analysis, see the following article in this issue of *Science in School*:
Gadd K, Szalay L (2008) Chewing flavours. *Science in School* 8: 34-37. www.scienceinschool.org/2008/issue8/chewing
- w9 – The ProBase website is under development but is expected to be ready by the end of 2008: www.pro-base.eu

Ken Gadd works for 4science, UK, and Luca Szalay is based in the Institute of Chemistry at Eötvös Loránd University, Hungary.



Image courtesy of the StandardBase project team



The StandardBase project team

What do we know about climate? Investigating the effects of anthropogenic global warming

In this, the second of two articles, climate researcher **Rasmus Benestad** from the Norwegian Meteorological Institute examines the evidence that humans are causing climate change.

It is well established that there is a natural greenhouse effect on Earth that makes the planet inhabitable. So what about anthropogenic global warming (AGW)? After all, natural climate variations existed long before man intervened; just look at the ice ages.

From theoretical considerations, you would expect that temperature would increase if heat loss was inhibited while energy supply was constant. Increasing the concentrations of greenhouse gases (GHGs) has the same effect as restricting heat loss, as GHGs are transparent to sunlight but opaque to the infra-red light that constitutes Earth's heat loss to space. Thus, an increased greenhouse effect disrupts the radiative energy balance.

The primary *empirical* evidence for an ongoing climate change includes a ~30% systematic increase in CO₂ levels since a pre-industrial level of 280 parts per million (the black curve in the figure on page 49 shows CO₂ levels since 1958). There is no doubt that

the CO₂ is from fossil sources, as isotope ratios show that the carbon has been less exposed to galactic cosmic rays (GCRs). When protons from GCRs collide with the nitrogen-14 (seven protons plus seven neutrons in the nucleus) in the air, carbon-14 is created (in addition to other isotopes such as beryllium-10) through a nuclear reaction:

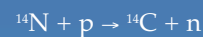

This means that carbon with a low isotope carbon-14 ratio must come from deep in the ground, out of reach of cosmic rays.

Furthermore, the ratio of O₂ to N₂ has diminished. This is expected from the increased combustion of fossil fuels, in which O₂ combines with C to form CO₂. The oceans have also become more acidic, leading to an increase in CO₂ levels in both the atmosphere and the oceans.

After all, carbon cannot spontaneously vanish from the face of Earth – under normal circumstances, it is conserved. Hence, the burning of fos-

sil fuels is expected to produce a surplus of CO₂ somewhere in the atmosphere, oceans and/or the biosphere. Extracting fossil carbon from deep underground removes it from these hidden reservoirs and releases it to the surface of Earth, where it remains.

According to the Fourth Assessment Report (AR4) from the Intergovernmental Panel on Climate Change (IPCC), the global mean temperature, estimated from thousands of individual thermometers scattered around the globe, has increased by 0.74 ± 0.18 °C over the past 100 years, and appears to be rising still. Some satellite-based studies have also reported changes in the spectral characteristics of the heat radiated from Earth, in line with an increased greenhouse effect. Bore-hole measurements from below the surface can also be used to infer temperature changes, and these too indicate that there has been a warming.

The global mean sea level is increasing, both due to the fact that warmer water has greater volume and because glaciers have melted. It has also been documented that most glaciers worldwide have retreated since the end of the 19th century. The sea-ice cover in the Arctic has diminished

Image courtesy of Rob Friedmann/iStockphoto



substantially since satellite measurement began, and the snow extent has decreased too.

There is also evidence from the hydrologic cycle: signs of more frequent intense downpours, and changes in the river discharge and rainfall statistics.

Additional reports on biological responses fit into the picture of a global climate change. Changes in the tree line, tree ring widths/density,

corals, sea-bottom sediments and staghmites bear witness to how the climate has varied in the past. Compared with these indicators, the present warming seems to be exceptional for at least the past 1000 years.

Doubts?

Those who dispute the notion of an AGW, popularly called *climate sceptics*, have argued that global warming is a consequence of changes in the Sun. But modern measurements of cosmic rays, sunspots and other indices used to describe the state of the Sun suggest that it has not become more active since the 1950s (see graph on page 50).

Variations to the Sun's behaviour would not necessarily exclude the role of GHGs in climate change. If our climate were to be sensitive to slight changes in the Sun, then it would suggest that our climate is easily affected by changes in the energy balance – hence a stronger reason to think that changes in GHGs could cause a global climate change.

Other factors may affect the radiation balance, such as changes in Earth's orbit around the Sun, and solar activity. Volcanoes are known to

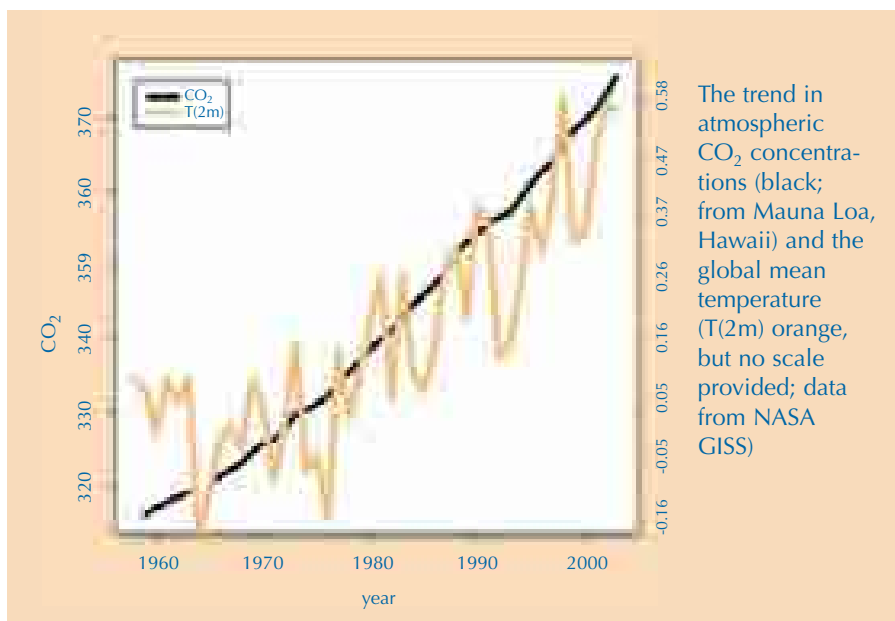
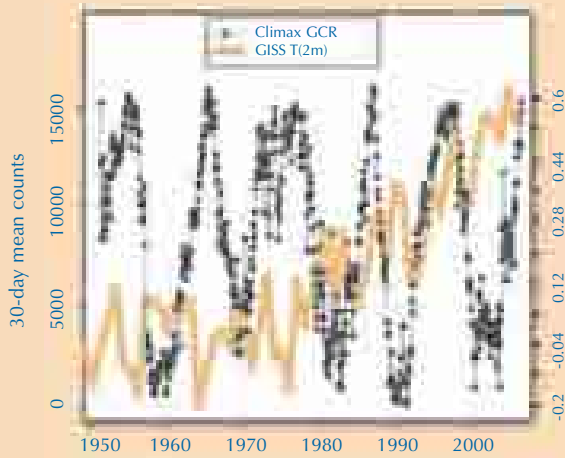

Image courtesy of Rasmus Benestad

Image courtesy of Rasmus Benestad

Climax galactic cosmic ray (GCR) counts 1951 – 2006



Comparison between galactic cosmic rays (GCRs; grey) and the global mean temperature (T(2m); orange). Although there is no long-term trend in GCR behaviour, the T(2m) has risen

inject particles into the upper atmosphere that block sunlight, and natural as well as anthropogenic aerosols may also have a ‘dimming’ effect, reducing the amount of energy from the Sun that reaches Earth’s surface. Aerosols may also affect Earth’s heat loss – the net effect depends on the type of particle, their size, altitude and concentration.

Changes in land surface may also play a role by changing the way the planet reflects light as well as the exchange of moisture and energy between the surface and the atmosphere.

Some sceptics argue that global warming is an illusion due to the effect of urbanisation. However, this does not explain how most of the world’s oceans have warmed both near the surface and at depths – where there are no cities. Nor does it explain why the greatest warming has been observed in the Arctic, Alaska and Siberia. Besides, the urban influence on the temperature record has been studied and taken into account when estimating the global mean.

Another argument used by climate sceptics is that satellite measurements of the temperature in the atmosphere do not show similar warming as on the ground. This discrepancy was due to errors in the analysis of the satellite data; the trends in the free atmos-

phere have now been reconciled with the surface data.

Others have argued that our atmosphere is already opaque to infra-red radiation and is hence saturated, so

any additional CO₂ will not have much effect. However, one only has to look to Venus to see that the atmosphere doesn’t saturate that easily. One can also show this theoretically. Besides, it is not only the effect of CO₂ that matters, as there are important feedback processes which may amplify (such as retreating sea ice, or air moisture) or dampen (low clouds, for example) the response to a changing greenhouse effect.

But hasn’t the climate always been changing? There are scholars who argue that our climate has a naturally cyclic behaviour. How do we know that the present warming is not just a part of a natural cycle, such as a rebound from a short ice age?

We can deduce from the laws of physics that the mean temperature does not just change spontaneously,

Condensation trails



This MERIS (MEdium Resolution Imaging Spectrometer) shows much of north-eastern Europe, including areas of Germany, Sweden, Poland and Denmark.

The elongated clouds around and to the east of Denmark, particularly visible over the sea, are in fact condensation trails formed by water vapour from aeroplanes. The number of contrails reflects the high level of air traffic

in the skies. It is thought that these contrails can form high-altitude cirrus clouds, which could contribute towards global warming.

Work within ESA’s Data User Element (DUE) currently includes studies into condensation trails and any effects they might have on climate change.

Image courtesy of ESA

as heat must be conserved. In the past, something in particular caused the variations – be it changes in the Earth’s solar orbit, atmospheric composition, solar activity, volcanoes or landscape changes. None of these factors, except for changes in GHG concentrations, can explain the current warming. Even changes to the system itself, such as El Niño Southern Oscillations, may produce some variations, but these tend to be weak compared with the changes due to external forces. And regardless of cause, there is always a physical explanation for the changes, be it external or internal.

Can we really trust global climate models (GCMs)? GCMs are not perfect, but they are still the best tool available for making projections for the future. A GCM may be thought of as a jigsaw puzzle, where the large picture emerges from small pieces put together in a consistent and organised manner. GCMs incorporate everything we know about the climate system in terms of physical laws and empirical data, and provide a comprehensive picture through the means of numerical methods on large computers. Some equations describing the processes cannot be solved exactly, but approximations nevertheless provide a good representation.

Projections for the future

So what can we expect from an AGW? The scientific findings published in peer-reviewed scientific journals have been collected and assessed in the IPCC’s report, which then presents the main picture for the future.

According to the AR4, an AGW will very likely result in a general warming, with a stronger response in the Arctic and over the continents. In the sub-tropics, there may be more droughts, but higher latitudes are expected to receive more precipitation. The report suggests that there will be more floods and famines. The glaciers may melt, reducing the sup-

ply of drinking water for a large part of the world’s population. A sea-level rise will affect low-lying coastal land areas, and in some regions people may be forced to move to higher ground.

The hurricane season of 2005 produced an unprecedented number – at least in modern times – of tropical cyclones in the Caribbean/North Atlantic, some of which resulted in substantial casualties and severe damages. Will there be more frequent or more powerful hurricanes/typhoons when the world is warmer? And are we now witnessing a trend in tropical cyclone activity? At present, we cannot be sure, although there are some indications that the potential for storm intensity may rise, and that there has been an upward trend in the activity associated with the more intense tropical cyclones over some ocean basins.

Social aspects

In addition to the scientific issues surrounding AGW, there are clearly ethical aspects too, such as those associated with the realisation that rich countries bear most of the responsibility for increased emissions of GHGs but are the least affected^{w1}. There are also energy considerations, and the question whether renewable sources of energy can replace fossil sources. Furthermore, economic considerations and political choices concerning climate change are closely related to energy options and greenhouse gas emissions.

The climate debate may indeed be one of the most profound issues of our time. It would be a shame if the broader public could not participate in this debate due to lack of understanding. Hence, it is important that schools teach students about climate and climate change, and that their information is accurate and up-to-date.



Everyone has heard about climate change. The subject is frequently addressed by the media, but the information given is often incomplete or biased by political views. As science teachers, we have to provide students with correct information and instruments to develop critical attitudes based on facts and aimed at active citizenship.

This second of two articles by Rasmus Benestad is very useful because it presents the topic clearly and objectively, addressing the evidence for anthropogenic climate change.

I recommend this article to science teachers who are willing to update their knowledge and to secondary-school students interested in the facts and scientific evidence at the heart of this debate. The material is also particularly suitable for classroom discussion and for an interdisciplinary approach to environmental education in secondary schools.

Giulia Realdon, Italy

REVIEW

Web references

w1 - For a discussion of the politics of climate change, see:
www.opendemocracy.net



A vibrant, high-contrast image of the Sun's atmosphere. The background is a deep red, with bright orange and yellow structures resembling solar flares or coronal mass ejections. A large, dark, circular feature is visible in the upper left, possibly a sunspot or a shadow from an observation instrument. The overall scene is dynamic and energetic, capturing a powerful solar event.

A coronal mass ejection
taking place

Research into the Sun's atmosphere

Image courtesy of SOHO (ESA & NASA)

Ever wondered what the solar wind means to us on Earth or what happens when the surface of the Sun erupts sporadically? **Lucie Green** from University College London's Mullard Space Science Laboratory, UK, describes some of the recent research into the Sun's atmosphere.

A special programme of research investigating the Sun and its influence on the Solar System is currently underway. Initiated by the United Nations, the programme is called International Heliophysical Year^{w1} and scientists all across Europe are taking part. One topic of interest is the Sun's atmosphere; there are many questions about our local star still to be answered.

One of these questions arose in 1869, when spectroscopic observations of a total solar eclipse revealed a spectral line which was unrecognised in laboratories. Initially believed to be

a new element and provisionally named 'coronium', it was later found to be produced by highly ionised iron ions, which need very high temperatures (of about 1 million Kelvin) to form. This discovery in 1939 was the first indication that the gases in the solar atmosphere were much hotter than the surface temperature of 6000 Kelvin. This then presented a puzzle. As you move away from the heat source (the core of the Sun), the temperature should drop. This is the case until you reach the top of the photosphere, but then the temperature starts to increase with distance from the core. This goes against the second law of thermodynamics; a cooler body cannot heat a hotter one. The question then arises, what heats the solar corona? This is now known as the coronal heating problem.

Despite the discovery of the first coronal emission line at a visible wavelength, most of the emission from the corona is at ultraviolet and X-ray wavelengths. When the space era began in 1957, X-ray telescopes on rockets and satellites were able to collect data from outside the Earth's absorbing atmosphere and allowed scientists to start studying what processes are at work. Observations quickly showed that bright X-ray emission was seen in the regions of the Sun's atmosphere where the magnetic fields are the most concentrated. Is there a link between the magnetic fields and the heating?

Observations taken from spacecraft such as the European Space Agency/National Aeronautics and Space Administration SOHO mission in 1995 are being used to test a number of theories. The theories fall into two categories: stressing models in which energy is extracted from magnetic fields that thread the corona, and wave models in which energy is deposited by waves that propagate up from below. The favoured idea at the moment is that the energy is derived from the magnetic fields

Image courtesy of SOHO (ESA & NASA)

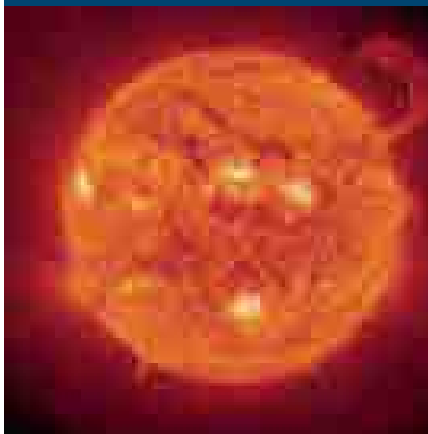

The chromosphere taken with the SOHO spacecraft

Image courtesy of SOHO (ESA & NASA)

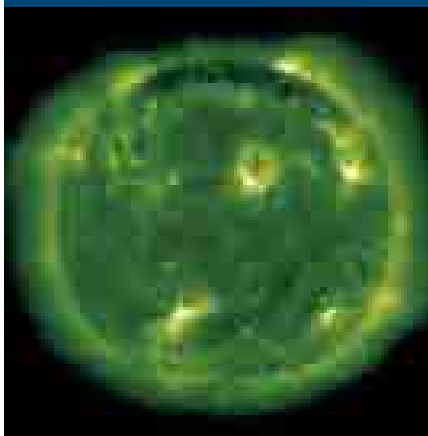

The corona taken with the SOHO spacecraft

Image courtesy of the Transition Region and Coronal Explorer (TRACE) / Dick Shine

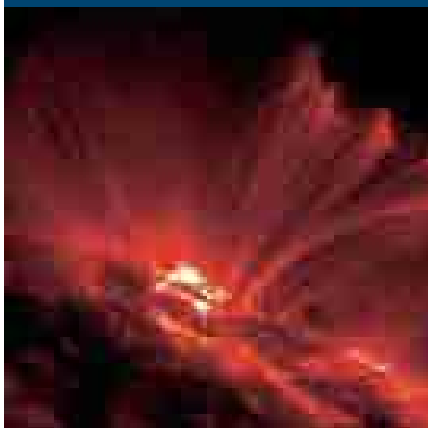

The structures in the solar atmosphere which are created by the magnetic fields

which are constantly being jostled and moved around, but research is ongoing.

One consequence of the Sun's hot corona, along with its high thermal conductivity, is that it is constantly expanding into space. This expansion is called the solar wind and there are two types: the slow wind which travels at about 400 km/s and the fast solar wind which travels at about 800 km/s. Currently, neither the acceleration mechanisms nor the locations of these two types are really understood, but both are being investigated.

The solar wind blows over all the planets and other bodies in the Solar System. Some planets, like Earth, generate their own magnetic field: those that have either a core of molten iron (like Earth) or an atmosphere of hydrogen that is so compressed that it acts like a metal (like Jupiter). This forms a magnetic bubble around the planet, around which the solar wind normally flows. The planet and its magnetic field act like a boulder in a river, deflecting the stream. However, the solar wind carries with it a magnetic field and if this has a strong southward orientation, it lines up with Earth's magnetic field. During these times, enhanced auroral displays (the Northern and Southern Lights) are produced. Work is being carried out to determine how the energy from the solar wind is transferred into the Earth's magnetic field and atmosphere. Research is also being carried out to see how the solar wind affects planets without a magnetic field. For example, the Venus Express mission is currently in orbit around Venus and is measuring the erosion of the Venusian atmosphere by the solar wind.

The most dramatic form of activity that takes place in the Sun's atmosphere are huge eruptions of plasma and magnetic field known as coronal mass ejections, or CMEs. Originally discovered in the 1970s, it has since been shown that their frequency

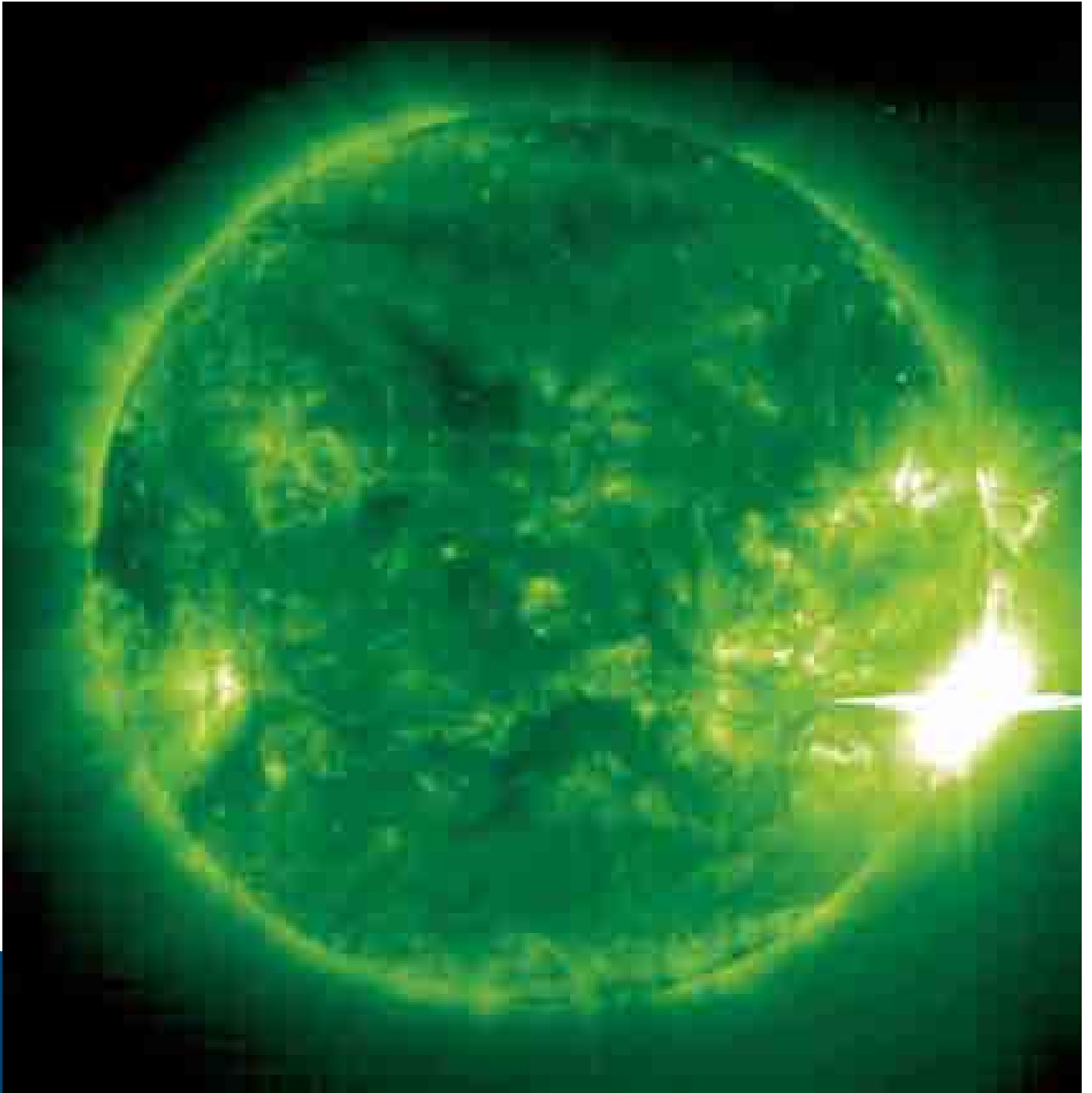

A solar flare taking place in the Sun's atmosphere

varies cyclically (with what is known as the solar cycle): CMEs occur a minimum of once every three days, and a maximum of three to five times per day. These eruptions can be directed towards Earth and, just like with the solar wind, a connection to Earth's

magnetic field can be made. Under these conditions, severe consequences are felt on Earth; heating and expansion of the Earth's atmosphere leads to changes in satellite orbits. The very real effect of CMEs makes them incredibly interesting to study and

there is currently a fleet of spacecraft observing the Sun and Earth to do just this.

The cause of CMEs is known to be related to the Sun's magnetic fields, which are created by electric currents in what is called the solar dynamo,

deep in the interior. Bundles of concentrated fields rise and emerge through the photosphere and extend up into the corona. This magnetic field is continually being injected into the atmosphere and it is thought that CMEs provide a way to remove it and prevent a build-up. Studies are being carried out, with spacecraft such as SOHO, TRACE, STEREO and Hinode, to monitor how the magnetic field structures change over time.

The STEREO mission consists of two spacecraft orbiting the Sun in a way that allows them to move away from Earth in space (one orbit is slightly closer to the Sun than the Earth's, and one slightly further out). This means that the two spacecraft view the Sun from different positions in space and just as our two eyes give us a sense of depth and perspective, the STEREO spacecraft are giving a 3D view of the erupting magnetic structures (see bottom image on p 53). The 3D view is being used to try and work out the physics of the eruption using knowledge of the structure of the magnetic fields. STEREO is also helping predict which CMEs will col-

lide with Earth. This knowledge could be used by satellite operators or organisations that run electricity grids: for example, the orbits of satellites could be particularly closely monitored when it is thought that CMEs will collide with Earth.

The Hinode spacecraft is the equivalent of the Hubble Space Telescope for the Sun, and it is allowing the study of the evolution of the immense atmospheric magnetic structures over time in great detail. It is thought that the only way to get enough energy to expel the billions of tonnes of solar material that make up a CME is by using energy stored in the twisted and distorted magnetic fields. Hinode is making measurements of how twisted the field is and the results are being combined with those found using STEREO. Once we understand why CMEs occur, we can start to predict which magnetic structures will erupt and eventually which ones will have the greatest effect on Earth.

The continually blowing solar wind and sporadic CMEs mean that Earth is always feeling the presence of the Sun. In fact, it can be said that we are

sitting in the atmosphere of the Sun, which is expanding into the Solar System. So, as well as the fundamental science that is being carried out to understand our local star, we want to understand our place in the Solar System too.

Web references

w1 – For more information about the International Heliophysical Year (2007-2009), see:
<http://ihy2007.org/>
 and www.sunearthplan.net



A close-up of the chromosphere



Image courtesy of Hinode JAXA/NASA

On the trail of a cure for cancer

Joan Massagué has discovered secrets that can save lives. An expert in cell division and the spread of cancer, he is one of the 50 most quoted researchers in all scientific fields. He speaks to **Sarah Sherwood** about his recent work on metastasis and his hopes for a cure for cancer.

Image courtesy of IRB Barcelona



Joan Massagué

What got you started in science?

Nature and collecting things have always fascinated me. I remember the day we studied minerals in elementary school. The simple concept that metals could be extracted from miner-

al ores was like an epiphany for me. I was certainly curious about how things in the natural world worked, and I was fortunate enough to have parents who understood and cultivated this. They stimulated me and facil-

itated my learning – but never forced me. I think this instilled in me a true desire to learn more about things. On top of curiosity, family tradition certainly played a role. I come from a family of three generations of phar-

macists – my grandfather, uncle, father and mother were all pharmacists.

Naturally when it was time to decide what to study at university, I chose pharmacy. My studies went well, and I went from exam to exam, but it wasn't until the fourth year of the five-year programme that I realised that my true love was biochemistry. It seemed to me to be a boiling pot for ideas. The structure of DNA had been solved some years before, and provided a cornerstone on which many principles of biochemistry were based. Concepts like hormones acting on cells – and the possibility of understanding what exactly they were and what they did – intrigued me. So I decided to switch and do a doctorate in biochemistry.

My PhD thesis focused on the metabolism of glycogen and its control by insulin, a molecule that is involved in diabetes. One day the director of the department asked me, "Well, what is it you want to do?" I replied, "Find a cure for diabetes, of course." A good answer, he said, but too ambitious. Diseases need to be solved step-by-step and they would find a good enough project for me to work on. I remember nodding and giving him a vague answer, but thinking inside, "But what I really want to do is find a cure for diabetes."

From 1976 to 1979, my research thesis and early development as a scientist flourished under the inspiring guidance of my doctoral mentor, Professor Joan Guinovart. At the same time, however, I witnessed the limited prospects that academic scientists had for a future career in Spain. Decades of negligence by the government, meagre resources and poor leadership had made the prospect of research most unattractive. So in 1979 I left for a period of postdoctoral training at Brown University in the United States, convinced that those were going to be my final years as a research scientist.

I envisioned returning to Spain to pursue a career as a pharmacist or in the local pharmaceutical industry. Instead, one thing led to the next in the USA, and after a productive post-doctoral period with Professor Michael Czech, I found myself in 1982 as the head of an independent laboratory group at the University of Massachusetts. At that time, I switched from the study of diabetes to the study of cell and tissue growth, which is of relevance to cancer. In 1989, I was offered a department chair at the Memorial Sloan-Kettering Cancer Center in New York and I have remained there ever since.

Your recent research focuses on the study of metastasis – the process by which a tumour spreads from one organ to another, and which causes 90% of all cancer deaths. How does this happen?

Until recently, metastasis was thought to be such a complex process that we didn't even know where to begin. In recent years, however, we have begun slowly but surely to uncover its secrets. It was impossible to say, for example, what made a cancer cell release itself from one tissue and what made it stick to another. We know, for example, that in order for normal tumour cells to metastasise, they must undergo certain genetic changes, and also that the tissues that these cells will colonise must have certain characteristics that favour the invasion and growth of the tumour cell. Many people don't know, for example, that cancer cells that originate in the breast tend to colonise the bones, lungs, liver or brain. Tumours in the colon, however, usually metastasise to the liver or lungs, but rarely to the bones or brain. We're not only uncovering the genes that permit these specific migrations to happen, but also getting a step-by-step look at the process.

Recent work from my laboratory, for example, shows that the combined

activity of four genes allows a tumour cell to escape from its natural habitat, and invade a distant organ. This is what happens when a breast tumour cell metastasises to the lungs. But what happens in one type of tumour does not always happen in another. We are now studying whether the same genes are involved, for example, in breast cancers that spread to the brain or to bones. Hopefully, if we can identify and understand the role of the genes involved in the spread of different types of cancer, we will be able to design drugs to deactivate these genes and halt the process.

Are you hopeful that a cure for cancer will be found in your lifetime? What do you think is needed to achieve this?

I'm very hopeful. Cancer treatment has seen incredible advances over the years and highly effective treatments now exist for certain types of tumours. Thanks to advances in research and the resulting drugs, some forms of childhood leukaemias, for example, have a remission rate of up to 90%, where patients show no signs or symptoms of the disease. However, there is still a long way to go. We need to discover new treatments that will be more effective, less toxic and less expensive than what we have at present.

It is clear that the best research, the kind that is really going to bring about important results, will require experts from many different fields working together – and for this we need better facilities and co-operation. Nowadays cancer research relies on sophisticated imaging techniques, high-resolution X-rays, genetics, gene transcription, computer science, molecular and cell biology, gene expression and biophysics – in addition to clinical expertise. This new culture of integrating clinical and experimental sciences creates real opportunities for productive interaction. The idea now is that within three decades we will know enough about

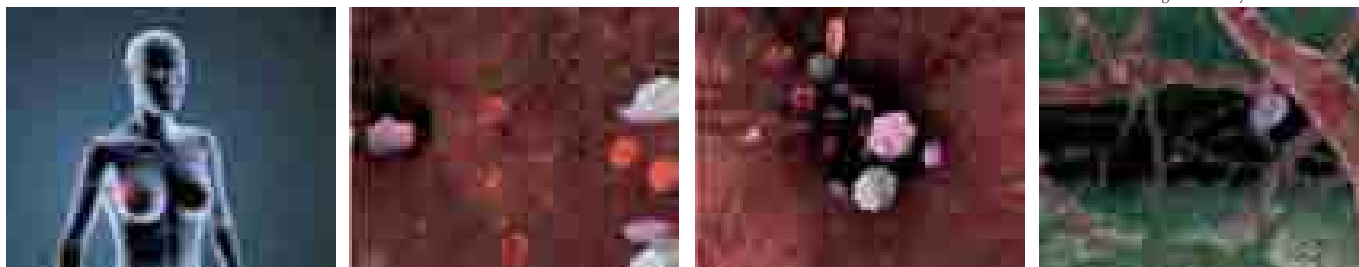

the biological and genetic basis of cancer to be able to make a difference.

How do results from research get out of the lab and into the hospitals where they can make a difference for patients with cancer?

Traditional therapies to treat cancer, including surgery, radiotherapy and chemotherapy, have made great strides in reducing the level of mortality caused by many types of cancer. But these strategies have generally focused on removing solid tumours, and then treating neighbouring cells with radiation and drugs to prevent the tumour from growing back. Often the main objective of this approach is to control the growth of the main tumour, when perhaps the problem also lies elsewhere – in secondary tumours that appear in other parts of the body when the cancer spreads or metastasises. Until recently, little research and few drug-discovery efforts have focused on this aspect. Knowing the genes that are involved in metastasis gives us some good targets for drugs that might work.

It is still early on, though, and the next step is to investigate these possibilities. First, potential drugs must be discovered and tested in the laboratory, in cell and animal studies. Once this process is finished and the potential drug proves to be promising, it must go through a series of clinical trials – developed by doctors – in which it is tested on a group of test patients with cancer to see how effective it is and whether it causes side effects. This is a long process, however, with no guarantees. In general,

only very few potential drugs found in the laboratory reach the point of clinical trials, and it can take up to 15 years for a drug to be approved. It's a long process with an enormous investment in terms of time, effort and money, but well worth it in the end when we manage to find a treatment that saves lives.

What would you say to a person with cancer, or someone with a loved one with cancer, who hears about your research and wants to know when a drug will be available to help them?

This is a very difficult question, and one that comes up often. I normally explain to people with these types of questions that I am not a physician and am not qualified to treat patients. I work in a lab and focus on the research behind the processes involved in cancer, not on developing the drugs or applying them to patients. The responsibility for treating patients and starting clinical trials, for example, lies with the doctors in the hospitals. What's for sure, however, is that to beat cancer, scientists and doctors must work closely together. It is, however, extremely gratifying when we make discoveries that end up helping people.

You left Spain 28 years ago for the USA and eventually the Memorial Sloan-Kettering Cancer Center. Now you are helping to set up the new Institute for Research in Biomedicine (IRB) in your native city of Barcelona. How important is it to bridge the gaps between research done in different parts of the world?

Though my research laboratory is based in New York, I collaborate all the time with other institutes at the local, national and international levels, including IRB Barcelona. This is the way research has to be done. Scientists realise that they cannot work effectively in isolation. Though they may be very good at their jobs, they'll never reach the goal of being able to translate basic research results into medical applications if they work alone. The idea is to combine scientific, technological and medical expertise to create strong integrated nodes with an international presence that can work together with similar institutes and hospitals across the world to share their knowledge and expertise.

It's an exciting time to be working in science. Through these types of collaborations, scientists now have many opportunities to spend time working in labs in different countries. Talent and passion for science can come from anywhere. Some members of my lab come from large cities with famous universities (such as New York, Los Angeles, Chicago, Santiago, Mexico, Toronto, Vienna, Munich, Rome, Madrid, Barcelona, Beijing, Calcutta, Tokyo and Istanbul) but others come from smaller towns. One student grew up in a remote Himalayan valley in Nepal, another in a tiny island off the coast of Iceland, another in a small town in northern Greece, and another in a rural area in Argentina, for example. With a positive attitude and a bit of luck, people with talent and passion always find a way.

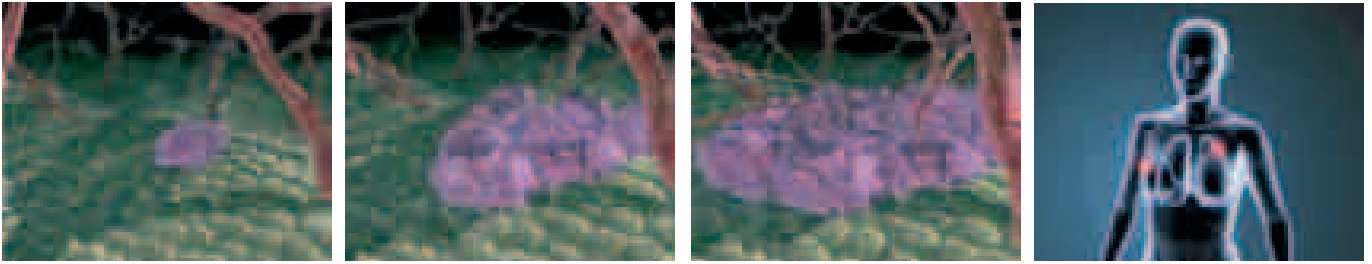

Cells from a breast cancer tumour release themselves from the tissue and migrate to form a metastasis in the lung



Joan Massagué is a well-known and respected international scientist. It is fascinating to read how he entered the research field. Like so many other scientists, he had ambitions to study other subjects and found an all-consuming passion along the way!

Professor Massagué is hopeful that therapies will be developed to block genes responsible for metastasis. In addition to providing an overview of current research, the interview could be used in several ways: to aid in comprehension; to complement lessons on cancer genetics; as a start for further research into leukaemia and solid tumours; to investigate the steps in drug development, from conception to clinical use; or to start a debate on government funding of cancer research and patient treatment.

Shelley Goodman, UK

REVIEW

As far as Spain is concerned, the situation is thankfully very different from when I left. There is a much better recognition on the part of the government of the need to create institutes and infrastructures that allow Spanish scientists to do really significant work. Spain has excellent cancer researchers who obtain very good results at the international level. However, their scientific results have traditionally encountered obstacles in being translated into tangible results. We will need to find a more efficient way to bring together the three main tools we have in the fight against cancer: basic, clinical and pharmaceutical research.

One thing is certain, however, and that is that the next generation of scientists stands a very good chance of making a real difference in the fight against cancer. Our job is to ensure that we nurture young talents and provide our biologists, geneticists, pharmacists and doctors with the training and resources they need to tackle the challenge head-on. My

advice for future scientists? Show up at your local college or university and talk to graduate students and other scientists. Ask them how they got started and what opportunities they know of for someone like you. Get diverse opinions, and then go for it!

Web resources

To find out more about the research group of Joan Massagué, see at: www.mskcc.org/mskcc/html/10614.ctm

For more information on the IRB Barcelona, see: www.irbbarcelona.org

Joan Massagué is Chair of the Cancer Biology and Genetics Program at the Memorial Sloan-Kettering Cancer Center in New York, USA, and Adjunct Director of the Institute for Research in Biomedicine in Barcelona, Spain.



Image courtesy of IRB Barcelona



Salt of the Earth

Prudence Mutowo can really identify with the organism she studies. After all, they have a lot in common. She told **Vienna Leigh** about researching a recently discovered archaeal species, *Haloferax volcanii*, which thrives in extreme conditions – and coming from Zimbabwe to the UK to pursue her career, Prudence is no stranger to those.

“I naturally expected to have a culture shock when I came to the UK,” says the University of Nottingham PhD student, who was originally able to come to study for her master’s degree thanks to a prestigious British Chevening Scholarship^{w1} for overseas students. “I expected the people, food, currency, language, culture and weather to be totally different. It didn’t disappoint, especially the weather!”

Unlike Prudence, though, the organism she studies challenges the definition of environments that we

term habitable – and much as they may hate the weather, even visitors from tropical climes can’t go so far as to describe the UK as uninhabitable. “*Haloferax volcanii* thrives in very salty environments like the Dead Sea,” explains Prudence. “In such concentrations, DNA and protein aren’t able to form crucial interactions for vital cellular processes. Most organisms exposed to such extremes of salt are known to die in such conditions. Also, *Haloferax volcanii* is known to have a complex internal system, yet it exists as simple single cells that are

easy to study. I had to learn more!”

Prudence grew up in Mutare, the fourth largest city in Zimbabwe, and credits such an environment for much of her interest in pursuing science. “Zimbabwe has a diversity of animals and wildlife, so the surroundings themselves provoked questions about the origins of life and issues of species diversity,” she remembers. “School provided some of the answers I was looking for, as we had an environmental science lesson every week.”

After studying for her bachelor’s degree in biochemistry at the

Victoria Falls, Zimbabwe

Image courtesy of Prudence Motowo



University of Zimbabwe and five years of research and development work in pharmaceuticals, Prudence was awarded the Chevening Scholarship by the British Council to study a master of science in applied biotechnology at the University of Nottingham^{w2} in September 2003. Part of her motivation in applying for this course was the chance to undertake an industrial placement with a UK pharmaceutical company, to see how this compared with her experience in Zimbabwe. During this fulfilling and interesting time, Prudence attended a lecture on halophilic (salt-loving) organisms (see box) by her current supervisor, Dr David Scott^{w3}. The Scott Group work on a variety of biophysical and biological problems centred on how organisms deal with and process biological information. Current projects study olfaction, archaeal transcription, aggregate structure and formation in pharmaceutical preparations, and development of methodologies to cope with non-ideal highly concentrated solutions. Fascinated, Prudence had found the perfect subject for her PhD research.

However, having an invitation to stay and continue her research wasn't

enough; Prudence had to finance her stay somehow. "Being a non-EU candidate, I wasn't eligible for many of the funding awards available, and I was faced with raising £11 000 [approximately €16 000] per year to continue," she says. "Considering how engrossed I had become in this research, I wasn't letting it go easily! I applied for every possible award I could find, and was lucky to receive a one-year tuition scholarship from the international office at the University of Nottingham. This covered the research fees only, so I also worked extra time as a resident tutor as well as demonstrating science practicals for the masters and undergraduate course to pay my bills."

After two years Prudence was lucky enough to be able to continue her research with a fellowship from the L'Oreal-UNESCO Women in Science initiative^{w4}. The award recognises interesting and potentially useful research projects being carried out by young women from each of the five continents. "The eve of my birthday, when I was informed I was a recipient of the fellowship, was the most memorable moment for me to date," she says. "The applications had had to be submitted through the UNESCO

commission in my home country, so after multiple cross-continent telephone calls, protracted periods of being kept on hold while the relevant person was located, and fax machines that seized up on the last page, my application was in. But with a whole continent to compete with, I was hardly placing my bets on this one.

"Had I not received the fellowship, it would have been nearly impossible for me to continue work. Now, *Haloferax volcanii* and I have been reunited for another year, at least until I officially complete my PhD."

Despite the hardships, though, Prudence never doubted that she'd made the right decision. "Researching in Nottingham has been wonderful for me. The university hosts top-of-the-range biochemical and analytical equipment, like the powerful analytical ultracentrifuges that allow the study of molecules in solution. This is ideal for looking at interactions that need to be maintained in an environment not unlike the Sea of Galilee," she says.

"I work alongside people from over 20 different nationalities, and the potential for exchange of ideas – cul-



Halophiles

Halophiles^{w5} are single-celled organisms that inhabit hypersaline environments. The mechanisms they use to cope with high salt concentrations are still not clear and hence are currently intensively studied. Some halophilic organisms, termed obligate halophiles, will die if removed from an environment with a high salt concentration.

BACKGROUND

turally, scientifically and socially – is amazing. The connections between research institutes within the UK and Europe has allowed me to go to Switzerland, France and other labs within the UK for conferences and laboratory sessions.”

In March 2007, Prudence was privileged to attend the Biovision Life Sciences Forum in Lyon alongside 100 other PhD students from all over the world, and listen to talks by “five life-science Nobel Prize winners! It was inspirational to be given a chance to speak to the people who had discovered the very tools I am using in my research,” she says.

She’s totally dedicated to continuing a career in science after finishing her PhD. “I would love to do more science communication as I find it very rewarding, and would also like to get involved in science policy and science and society activities,” Prudence says. “But I’ll definitely stay in research. I love its unrestricted nature, in that it allows you to focus on a question or issue and pursue the answers in as many different ways as possible.

“Another huge attraction is that research has the potential to yield great benefits to human life. The findings from my own research, for example, may be applicable in understanding the possible origins of life as well as understanding the ability of some

organisms to inhabit extraterrestrial environments – a field known as astrobiology. Enzymes from extremophilic micro-organisms have great potential in natural resource processing in the petroleum, detergent and food industries.”

And what about her own adaptation to her extremes in environment? “Though it took a while to get used to the UK, I was not expecting to feel like an outsider when I eventually returned to my home country for a brief holiday,” she says. “Friends had got married and moved on; the sunny climate I had enjoyed seemed overly warm. The food tasted a bit strange and, in an unexpected twist, I missed the cold!

“But as we were approaching London, the captain announced that the ground temperature at Heathrow was -2 °C. I had walked out of a tropical summer’s day to sub-zero temperatures. But I was so happy to be back to salty organism research... and the serial tea-drinking!”

Web references

w1 – The British Chevening Scholarships award scholarships to overseas students in more than 150 countries to study in the UK. See www.chevening.com

w2 – The University of Nottingham website: www.nottingham.ac.uk

w3 – For more information on Dr David Scott and his group at the University of Nottingham, see www.nottingham.ac.uk/biosciences/lookup/lookup_az.php?id=ODAzMTg5&page_var=personal

w4 – For more information about the L’Oreal–UNESCO Women in Science initiative, see www.loreal.com/_en/_ww/loreal-women-in-science/

w5 – Wikipedia entry for halophiles: <http://en.wikipedia.org/wiki/Halophile>

Resources

To read about halophiles on the ThinkQuest website, a site for children, written by children, visit <http://library.thinkquest.org/CR0212089> and click on ‘Enter Site’ then ‘Halophiles’

‘Wild Things: The Most Extreme Creatures’: an article on the LiveScience website: www.livescience.com/animals/050207_extremophiles.html

For more information on extremophiles in general and microbial life in hypersaline environments in particular, see Carleton College’s Microbial Life Educational Resources: <http://serc.carleton.edu/microbelife/>



Paul goes back to the classroom

As any teacher knows, the job isn't exactly easy. So what makes a professional, experienced bioinformatician want to give up an established career to brave the front of a classroom? **Vienna Leigh** from the European Molecular Biology Laboratory investigates.

After five years at the European Bioinformatics Institute (EBI)^{w1} in Hinxton, UK, Paul Matthews is making a brave move. On a scheme called the Graduate Teacher Programme^{w2}, Paul will spend one academic year teaching at two UK schools, after which he will be expected to have passed all the standards to become a qualified teacher. The programme is designed to encourage professional people with financial commitments, and scientists in particular, to enter teaching and fill the chronic shortage of science teachers.

"I feel really lucky to have got on this scheme; in my area it involves academic help from Cambridge University, some very good local schools in the partnership and the local authority," explains Paul. In his new job, he will teach children aged 11-16 biology, physics and chemistry, and students aged 16-18 his specialist subjects, biology and human biology, for the A level and the international baccalaureate.

Paul had many reasons for his decision, and has definitely had plenty of

time to think about it. Last year, he underwent major surgery for a congenital heart problem, and the three months' convalescence gave him a lot of time to reflect on his future.

"I'd recommend open heart surgery to anyone who needs to work out what to do with their life!" he laughs. "It gave me the time to sit down and really think about what to do next – and what is right for me at this stage of my career. I've worked in industry and academia for many years and really wanted a change."

He's leaving the EBI, located on the Wellcome Trust Genome Campus near Cambridge and part of the European Molecular Biology Laboratory (EMBL). The scientists there collect, store and curate databases of biological data including protein sequences and macromolecular structures, in effect 'parts lists' for many living organisms, so other researchers have a repository of data to help them look at how the individual components fit together to build systems.



Image courtesy of Ugur Evrigen/iStockphoto

In running the institute's industry support programme, Paul catered for the major impact that advances in bioinformatics have on industry. The programme provides training in the databases, develops bioinformatics standards, helps industry partners with technical development and provides networking opportunities. The partners Paul dealt with every day included large, multinational biotech, pharmaceutical, agricultural, nutrition, personal care and medical device companies.

Paul's decision to change jobs has had both emotional and practical considerations. "I've always enjoyed the teaching I've done as part of my job in the past," he says. During his 13 years in bioinformatics, both in companies such as GlaxoSmithKline and academic organisations including the Wellcome Trust Sanger Institute and the EBI, he's had a lot of experience in the classroom and is equally happy presenting to 20 or 200, but as he says, "so far it has always been adults, and they were always already interested in science!" The Graduate Teacher Programme is, therefore, allowing Paul to fulfill a long-term dream. "I've often thought about going into teaching, but I've never been in a financial position to do so," he says. "I thought about it seriously before I came to the EBI, but then I had a small family and lots of commitments. Now, things are a bit more settled, and the scheme allows me to train while retaining a steady income."

Another persuasive aspect for Paul has been his own children. "I'm having more interaction with my kids about what they're learning at school as they get older, and more of an insight into what's going on in the schools," he says. "I want mine to have a good education in all subjects but it's almost naïve to expect that, as there's such a shortage of teachers, especially in science. Teachers have a difficult job and I don't think I can expect my children to be taught well



REVIEW

For anyone who faces the dilemma of whether to follow a career as a science teacher and for those who are already science teachers but have doubts whether they have made the right career decision, this article has all the answers. The interviewee, Paul Matthews, gives many reasons for becoming a high-school science teacher. His decision, based on a combination of unique personal, financial and social circumstances, is quite inspiring.

The article introduces a good debate topic and can be used in any science or non-science lesson. Questions such as 'Was Paul's decision a good one?', 'Will he be better off as a science teacher or will he regret it?' and 'Will he actually be in position to contribute more to society as a teacher?' can trigger lively conversations between students, especially when considering that the article deals with the students themselves.

Michalis Hadjimarco, Cyprus

unless, like the teachers, I would actually be prepared to get in there and have a go at it myself. So I thought, why don't I?"

Paul believes science suffers more than other subjects when it comes to children making their subject choices at key stages in their schooling. "If science isn't taught in a way that kids can relate to, then they very quickly dismiss it," he says. "If even the people who are teaching it aren't interested – because they're covering for someone, or are supply teachers, which is happening more and more often – they can't convey an excitement for the subject. If it's not something they're passionate about, how can they encourage the children to be interested in it?"

"It's not just the way it's taught, though. Science is most easily given up if it conflicts with other subjects. You never hear about someone having private tuition in science as they might in French, for example, if it clashes with something else in the curriculum."

Despite such challenges, though, Paul has mostly positive expectations about his new career. "I think switching kids on to science – finding ways

to engage them and make science relevant for them – will be a really rewarding challenge," he says. "That will be the hardest part – trying to find ways to make potentially disinterested teenagers see how much science is a part of their lives."

He's already had some experience of this challenge, having done several weeks' placements in his host schools. "One of those days just happened to be a taster session for ten-year-olds having their first science lesson, learning how to light a Bunsen burner and doing flame tests," he says. "Looking at their faces, not one of them was bored. Not every science lesson has that much hands-on fun, but if you see the light switch on in someone's face as they see something or understand something for the first time, it gives you a real buzz."

"I'm not naïve enough to think that they'll all want to learn science – and something certainly happens to make kids disinterested, between that young, excited age and adolescence, when they have to choose subjects, and I'm hoping to find out what that is. The opposite sex, maybe, or the perception that science is too hard, or not accessible enough."

“I don’t imagine I’ll be able to make them all brilliant scientists, but it will be nice to make a difference of any sort – to have a hand in making a well-rounded human being. Maybe one day I’ll call a plumber, and it will be one of my former pupils, and he’ll just be a nice guy. Having said that,

getting the first PhD thesis in science sent to me by a former student will be fantastic!”

Web references

w1 - The European Bioinformatics

Institute website is www.ebi.ac.uk

w2 - To find out more about the

Graduate Teacher Programme, see www.tda.gov.uk/Recruit/thetrainingprocess/typesofcourse/gtp.aspx

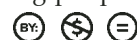

Image courtesy of EMBL Photolab



Choosing Children: Genes, Disability, and Design

By Jonathan Glover

Reviewed by Michalis Hadjimarcou, Cyprus

The aim of *Choosing Children* is to investigate how humanity should regulate its fast-increasing ability to genetically design the babies of tomorrow. Should there be an effort to eliminate from future generations any disabilities and disorders that are traditionally considered disadvantageous to human life? And should parents be allowed to choose the genetically determined characteristics and qualities of their children and even to enhance their mental and physical abilities?

These possibilities raise important issues such as the extent of freedom that should be given to parents to determine what their children will be like, while at the same time ensuring the children's right to a good life, which could require protecting them from their parents' foolish or even harmful choices.

In order to address these questions, Jonathan Glover first tackles essential issues such as how we define disability and which disabling conditions are sufficiently disadvantageous to be considered for elimination from future generations. Also, he tries to define what constitutes a 'good life' and explores the concepts of human flourishing and happiness. Eventually, he investigates how the principle of 'what parents owe their children', along with other guiding principles, should be used to direct all

decisions that parents are allowed to make for their children.

As the subject of this mostly philosophical book is contemporary and highly engaging, it is suitable for anyone who is interested, even slightly, in the topic of genetic intervention in humans. On the downside, the long and detailed philosophical and theoretical discussions can be tiring to the casual reader. Also, although the scientific knowledge required to understand the book is minimal, good command of the English language is required to fully appreciate the philosophical discussions.

Although the philosophical details in *Choosing Children* may make it a bit 'heavy' for some high-school students, the issues it raises could make excellent debate or discussion topics in science or even non-science classes. Also, teachers could design small projects around the disorders described in the book, providing students with essential information to help them argue either side of the debate.

No matter what their level of interest or knowledge, there is a good chance that Glover's discussion of these issues will make readers rethink and re-evaluate some of their previously held beliefs. This is, perhaps, one of the most important contributions of *Choosing Children*.

Details

Publisher: Oxford University Press

Publication year: 2006

ISBN: 9780199290925



Nontraditional Careers for Chemists: New Formulas in Chemistry

By Lisa M. Balbes

Reviewed by Eric Demoncheaux, Battle Abbey School, UK

Nontraditional Careers for Chemists: New Formulas in Chemistry is the perfect book for chemistry students who are interested in exploring career options beyond the laboratory. Lisa Balbes manages to convince the reader that science-trained professionals have many skills, including logical and analytical thinking, as well as research methods that are necessary to survive in today's workplace. She demonstrates that a chemistry background is essential for a plethora of positions.

Each chapter presents detailed profiles of several chemists who have achieved a successful career in their field of endeavour. The book contains valuable information on the types of skills, personality traits and knowledge required to be competitive on the job market.

Profiles of nontraditional chemistry careers include communications, information science, patent law, sales and marketing, business development, regulatory affairs, safety, computer science, human resources, public policy and education. All contributors give detailed accounts of their current positions and career paths, finishing with advice and predictions about the future of their jobs.

For example, TV producer and science writer Rani Chohan works at the National Aeronautics and Space Administration (NASA) in the USA. She graduated with a bachelor's degree in chemistry from Elmhurst

College in 1996 and a master's degree in journalism from the University of Wisconsin-Madison in 2002. Her job is to communicate the science of NASA to the rest of the world. Rani advises readers to love science, not to be afraid to explore different subjects and to build up a good writing portfolio.

Osman F. Güner is the Executive Director of Cheminformatics and Rational Drug Design at Accelrys Inc. Osman has a BSc and an MSc in chemistry from the Middle East Technical University in Ankara, Turkey, and a PhD in Physical Organic Chemistry from the Virginia Commonwealth University, USA. In his company, which makes computer science and informatics software, Osman is directly responsible for profits and losses, and he is involved primarily in product planning, management and marketing. Osman's top advice is that if you choose computational chemistry in life sciences as a career, you must be prepared to improve your knowledge and understanding of biology.

Finally, Linda Wraxall is a Criminalist Lab Safety Officer at the California Department of Justice DNA Laboratory, USA. During her BSc in zoology at the University of London, UK, she also took courses in botany and chemistry. Linda is responsible for the safety of more than 100 scientists in the laboratory. She oversees training, chemical inventories, trou-

bleshooting and preventative measures to keep her co-workers safe, healthy and productive. Linda's top advice is that networking is vital in any profession, particularly in her own job.

Nontraditional Careers for Chemists is a well organised and insightful book. It would be a useful resource for all teachers and career advisors

Details

Publisher: Oxford University Press

Publication year: 2006

ISBN: 9780195183665



Dance of the Tiger

By Björn Kurtén

Reviewed by Dean Madden, National Centre for Biotechnology Education, UK

Teachers and many older school students will enjoy *Dance of the Tiger*, a very unusual fictional story written by a scientist about his own subject.

The author, Swedish/Finnish palaeontologist Björn Kurtén, did not create the literary genre ‘palaeofiction’, but he was certainly one of its better writers. As Stephen Jay Gould said in his introduction to Kurtén’s novel (first published in Swedish as *Den Svarta Tigern* in 1978, and then in English in 1980), well-informed fictional accounts are often equally as valid as Rudyard Kipling’s ‘Just So’ stories created by evolutionary biologists. By presenting such stories in a fictional setting, however, their speculative status is made clear. Could such fiction, on screen as well as in print, have a role in science education?

Shortly after their remains were first discovered, the Neanderthals became popular subjects for fiction. Often they were wrongly portrayed as stooped, brutish creatures of low intelligence — due in part to a flawed interpretation of early fossil evidence which has coloured popular perception of Neanderthal man ever since.

However, sympathetic literary portrayals of Neanderthals are also common, such as in the novel *The*

Inheritors by Nobel Prize-winner William Golding or Kurtén’s more serious treatment, *Dance of the Tiger*. The novel challenges the reader to speculate about possible reasons for the Neanderthals’ extinction, with clues to three possibilities scattered throughout the text. At the end of the story, Kurtén reveals the answers, as well as the research findings that inspired several aspects of the story.

Although Kurtén’s 1978 work predates modern molecular studies, it highlights a possible method of teaching students about evolutionary processes in an entertaining manner.

Details

Publisher: University of California Press, Berkeley

Publication year: 1980

ISBN: 9780520202771



About *Science in School*

Science in School promotes inspiring science teaching by encouraging communication between teachers, scientists and everyone else involved in European science education.

Science in School addresses science teaching both across Europe and across disciplines: highlighting the best in teaching and cutting-edge research. It covers not only biology, physics and chemistry, but also maths, earth sciences, engineering and medicine, focusing on interdisciplinary work.

The contents include teaching materials; cutting-edge science; education projects; interviews with young scientists and inspiring teachers; European education news; reviews of books and other resources; and European events for teachers.

Science in School is published quarterly and is available free online; free print copies are distributed across Europe. Online articles are published in many European languages; the print version is in English.

Credits

Science in School is published by EIROforum (a collaboration between seven European inter-governmental scientific research organisations: www.eiroforum.org) and is based at the European Molecular Biology Laboratory (EMBL: www.embl.org) in Heidelberg, Germany.

Science in School is a non-profit activity, part of the NUCLEUS project supported by the European Union.

Disclaimer

Views and opinions expressed by authors and advertisers are not necessarily those of the editor or publishers.

Subscriptions

Science in School is freely available online and print copies are distributed across Europe. Register online to:

- Receive an email alert when each issue is published
- Request a free print subscription
- Swap ideas with teachers and scientists in the *Science in School* online forum.
- Post your comments on articles in *Science in School*.

Copyright

With very few exceptions, articles in *Science in School* are published under Creative Commons copyright licences that allow the text to be reused non-commercially. **Note that the copyright agreements refer to the text of the articles and not to the images.** You may republish the text according to the following licences, but you may not reproduce the images without the consent of the copyright holder.

Most *Science in School* articles will carry one of two copyright licences:

1) Attribution Non-commercial Share Alike (by-nc-sa):



This license lets others remix, tweak, and build upon the author's work non-commercially, as long as they credit the author and license their new creations under identical terms. Others can download and redistribute the author's work, but they can also translate, make remixes, and produce new stories based on the work. All new work based on the author's work will carry the same license, so any derivatives will also be non-commercial in nature.

Furthermore, the author of the derivative work may not imply that the derivative work is endorsed or approved by the author of the original work or by *Science in School*.

2) Attribution Non-commercial No Derivatives (by-nc-nd)



This license is often called the 'free advertising' license because it allows others to download the author's works and share them with others as long as they mention the author and link back to the author, but they can't change them in any way or use them commercially.

For further details, see <http://creativecommons.org>

All articles in *Science in School* carry the relevant copyright logos or other copyright notice.

Contact us

Dr Eleanor Hayes
Editor of *Science in School*
Office of Information and Public Affairs
European Molecular Biology Laboratory
Meyerhofstrasse 1
69117 Heidelberg
Germany
editor@scienceinschool.org

Submissions

We welcome articles submitted by scientists, teachers and others interested in European science education. Please see the author guidelines on our website for details.

Reviewer panel

If you would be interested in reviewing articles for their suitability for publication, please read the guidelines for reviewers on our website.

Book reviewers

If you would like to review books or other resources for *Science in School*, please read the guidelines for reviewing books on our website.

Translators

We offer articles online in many European languages. If you would like to help us by translating articles into your own language, please read the guidelines for translators on our website.

Advertising in *Science in School*

Science in School is the **only** European journal aimed at secondary- school science teachers across Europe, and across the full spectrum of sciences. It is freely available on the web and over 30 000 full-colour printed copies are distributed each quarter. The target readership of *Science in School* includes everyone involved in European science teaching, including:

- Secondary- school science teachers
- Scientists
- Science museums
- Curriculum authorities

Advertising rates

- Full page: € 3150
- Half page: € 2285
- Quarter page: € 990

We offer a 20% discount on advertisements that appear in four or more consecutive issues.

To advertise in the printed version of *Science in School*, please contact advertising@scienceinschool.org



Published by EIROforum:



Supported by the European Union:



Part of the NUCLEUS project:

