

## Potential Options

If required, the programme could be extended to take account of the variation of the PSF with position in the focal plane.

At present, the code assumes a spatially invariant PSF but, in contrast to, e.g., Fourier transform techniques, this assumption is not fundamentally demanded by the iterative deconvolution algorithm.

A further possibility is to develop a code that simultaneously deconvolves several images of the same field, each of which is displaced by a fraction of a pixel.

This possibility, which has been investigated theoretically by Adorf (1989), introduces an element of image reconstruction by tomography and might well be useful for certain objects with structure on the scale of the narrow core of the observed PSF.

## References

- Adorf, H.-M.: 1989, in Proc. 1st ESO/ST-ECF Data Analysis Workshop, eds. P.J. Grosbøl, F. Murtagh, R.H. Warmels, p. 215.
- Evans, I.N., Ford, H.C., and Hui, X.: 1989, *Astrophys. J.* **347**, 68.
- Heasley, J.N.: 1984, *P.A.S.P.* **96**, 767.
- Lucy, L.B.: 1974, *Astron. J.*, **79**, 745.
- Lucy, L.B. and Baade, D.: 1989, in Proc. 1st ESO/ST-ECF Data Analysis Workshop, eds. P.J. Grosbøl, F. Murtagh, R.H. Warmels, p. 219.

# ESO'S EARLY HISTORY, 1953–1975

## VIII. The 3.6-m Telescope Project; From Concept to the Late 1960's\*

### A. BLAAUW, Kapteyn Laboratory, Groningen, the Netherlands

*“Le programme initial de l'Organisation comporte la construction, l'installation et le fonctionnement d'un observatoire dans l'hémisphère austral, comprenant: a) un télescope d'environ 3 mètres d'ouverture; ---”*  
From the ESO Convention, Art. II.2.

## Introduction

This article reviews work towards the realization of the 3.6-m telescope from the early beginnings of ESO up to the moment, at the end of 1969, when Council drastically changed course. These early years saw an Instrumentation Committee, a Directorate and an engineering bureau devoted to the creation of an instrument of dimensions and costs, an order of magnitude larger than anything achieved so far in optical astronomy in Europe. Unfortunately, lack of experience proved to be a serious drawback, and this unavoidably puts its stamp on the present, somewhat cheerless, account. The new approach adopted by Council late 1969, will be described in the next article.

## Basic Concepts

A telescope project like the one for the ESO 3.6-m telescope, starts by specifying the dimension of the main mirror as this determines the light gathering power of the instrument, and by choosing the desired focal ratios for the different modes in which the instrument is to be used; the Prime focus, the Cassegrain focus and the Coudé focus. These focal ratios determine the dimensions of the telescope tube. The design of all other components of the project follows from these. It has been mentioned before (article IV) that the example ESO had in mind in the very beginning was the 3-m telescope of Lick Ob-

servatory, however the ESO design soon deviated from this.

Naturally, the designs of the various components of the project are interrelated, but once a certain stage has been reached, the further development and construction of the various parts tends to proceed largely independently. For our project this was particularly so for, on the one hand, the housing of the telescope, i.e. building and dome, and on the other hand the ensemble of tube, optics and mounting. Within the latter again a subdivision can be made: the combination tube/optics, and the mounting plus drive. The account on the progress in the project can be subdivided accordingly. Up to the early 1970's, the progress of the project as a whole was determined almost entirely by the (lack of progress in the) design of the mechanical parts of telescope tube and mounting. Contrary to what seemed to have been a tradition in earlier generations of large-telescope building, progress for the ESO 3.6-m telescope was not determined by the completion of the optics.

## Early Conferences and Texts

The early years of ESO's project coincided with a general, international broadening of interest in large-telescope building and the publication of significant documentation. In the year 1960 appeared the compendium “Telescopes”, Volume I of the series Stars and Stellar Systems edited by Gerard P. Kuiper and Barbara Middlehurst. It contained chapters by leading experts,

among which descriptions of the two recently completed largest instruments: of the 200-inch Hale Telescope by Ira S. Bowen, and of the Lick 120-inch by W.W. Baustian; and furthermore chapters on Design of Reflecting Telescopes by Aden B. Meinel; and on Schmidt Camera's, again by Bowen. This Volume became a basic reference text for the next decades.

Another important event was IAU Symposium No. 27, “The Construction of Large Telescopes” held from 5 to 12 April 1965 at Tucson, Arizona, and at Pasadena and Mt. Hamilton (Lick Observatory) in California. The proceedings, edited by David L. Crawford and published in 1966, contained much basic information and instructive discussion reports. Among the participants from ESO countries were Baranne, Bahner, Courtès, Elsässer, Fehrenbach, Heckmann, Ramberg and the engineer who worked for ESO, W. Strewinski. In the present context mentioning should be made also of K. Bahner's Chapter “Teleskope” in *Handbuch der Physik*, Vol. 29, 1967, and Bahner's article “Large and Very Large Telescopes; Projects and Considerations” in *ESO Bulletin* No. 5 of December 1968, which includes a summary of large telescope projects under design or construction in December 1967.

Finally, as a quite useful – and readable! – review of the main elements in large-telescope construction and the status of the principal projects, let me mention B.V. Barlow's monograph “The Astronomical Telescope” of 1975 [1].

\* Previous articles in this series appeared in the *Messenger* Nos. 54 to 60.

## The Choice and Ordering of the Optics

The increase of the originally suggested diameter of the big mirror from 3 to 3.5 m (eventually 3.6 m) was one of the outcomes of the visit of Fehrenbach and Heckmann to observatories in the United States in 1961 (see article IV). Experience with the recently completed Lick 3-m telescope had shown that the observers-cage at the prime focus was inconveniently narrow when used by a bulky observer. As, however, an increased diameter of the cage would block an unacceptably large part of the surface of the 3-m primary mirror for the infalling light, Heckmann and Fehrenbach suggested an increase of its diameter to 3.5 m [2]. The ESO Committee in its meeting of November 1961 took note of this, but thought it wise not yet to change the text of the Convention which was still in the process of being approved by the governments. For the time being, the formulation “un télescope d'environ 3 mètres d'ouverture” would leave the door sufficiently open for changing the size once signing and ratification would have passed. However, in the planning of the telescope, a mirror diameter of 3.5 m soon became the canonical figure, and this grew to 3.6 m after it had turned out later – in 1967 – that the blank of 3.72 m diameter, as delivered by the manufacturer, Corning, allowed a useful diameter of at least 3.6 metre. In retrospect, it seems to have been ESO's good fortune that one of Lick Observatory's most ardent observers of the 1950's, apart from being highly respected scientifically, also

was one of more-than-average circumference . . .

The order to Corning in its final form was placed on January 25, 1965. The blank, made of fused Silica, was accepted at Corning's (at Bradford, USA) on February 23, 1967 in the presence of Fehrenbach, Heckmann, J. Texereau (of the Laboratoire d'Optique of Paris Observatory) and J. Espiard of the firm of REOSC in Ballainvilliers, France, where the mirror was to be processed for its final shape. The contract with REOSC was signed in June 1967 and the blank arrived there later that year. After it had turned out in the course of 1968 that the blank showed certain superficial defects which required providing it with a new toplayer at Corning's, it was back again at REOSC in September 1969 for final processing. This was completed two years later; in February 1972 formal acceptance by ESO took place. By that time two studies of the properties of the mirror had been published. One, in 1967, by J. Texereau in collaboration with J. Espiard: “Examen du Disque en Silice Fondue de 372 cm pour European Southern Observatory”, and one, in 1971, by G. Lemaître of Marseilles Observatory: “Sur la Flexion du Grand Miroir de 3,60 m de European Southern Observatory”. These studies appeared in *ESO Bulletin* Nos. 2 and 8, respectively.

From the very beginning, the design for the telescope aimed at using it in the three modes: Prime, Cassegrain, and Coudé focus. Exact values of the three focal ratios – F/3, F/8, F/30 – were chosen by the Instrumentation Committee (IC) after consultation with various ob-

servers in the United States among whom especially I.S. Bowen, the Director of Mt. Wilson and Palomar Observatories, should be mentioned. At the first Council meeting after the ratification of the Convention, in February 1964, Fehrenbach as Chairman of the IC summarized the situation as follows.

“1 – Le télescope doit comporter un foyer Cassegrain ouvert à F/8 qui entraîne une ouverture du miroir principal comprise entre 2,7 et 3, le foyer Coudé ouvert à F/30.

2 – Un effort particulier doit être fait pour augmenter les champs de bonne définition. — —

5 — — — Une combinaison du type Ritchey Chrétien ouvert à F/3 doit permettre d'obtenir:

– au foyer Cassegrain, ouvert à F/8, un champ plan de 30' de diamètre (Solution de M. Köhler).

– au foyer direct, un champ de 1° avec lentilles minces et de diamètre relativement petit, dont une de surface asphérique. (Solution de M. Baranne.)

– un champ suffisant au foyer Coudé.”

A. Baranne of Marseilles Observatory and H. Köhler of Zeiss-Oberkochen, mentioned here, both experts in astronomical optics, had been engaged in the design since the early stage of the project; their studies contributed essentially to the final properties of the telescope. Early results of their work were communicated in *ESO Bulletin* No. 2 of August 1967: “Le télescope de 3.50 m de diamètre” by Baranne and “The Optical System for the 3.50 m Telescope” by Köhler [3]. Compared to the earlier generations of large optical telescopes, the ESO 3.6-m optics was designed to en-

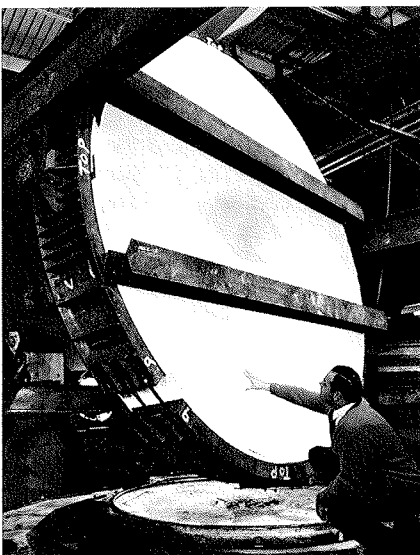

The mirror blank for ESO's 3.6-m telescope about to be delivered by Corning Glass Works. The right-hand photograph shows ESO's Director, Otto Heckmann, in discussion with a (yet unidentified) person of Corning's Management. The (undated) photographs were presented to ESO by Corning's.

From the EHPA.

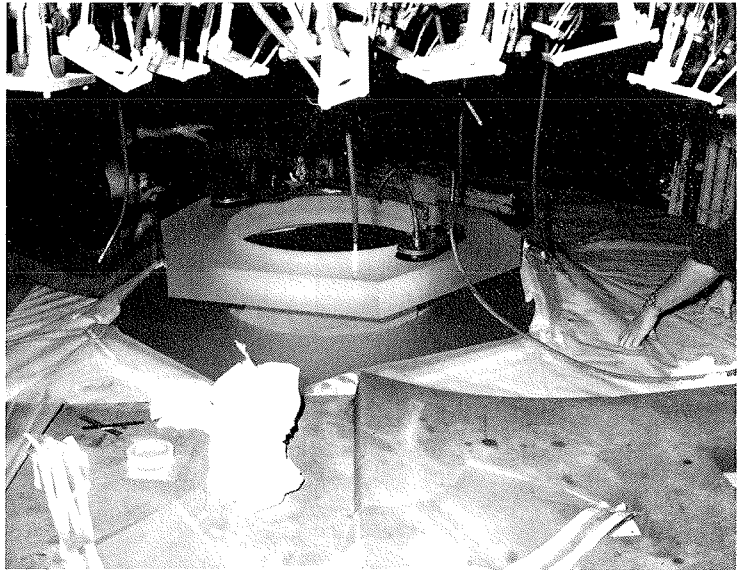
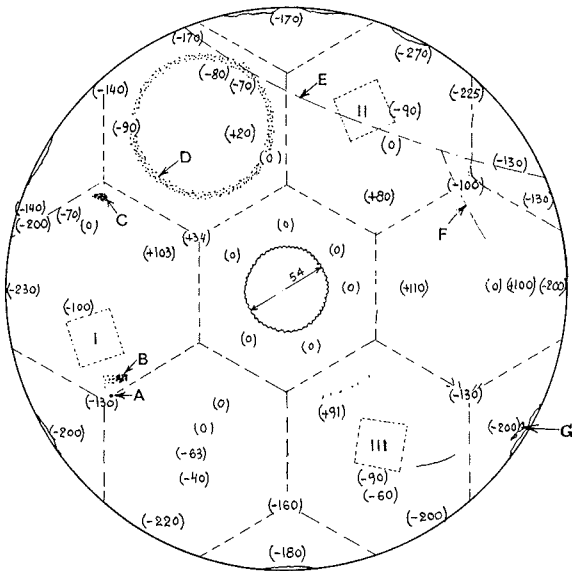

The mirror blank for ESO's Large Telescope, made of fused silica, was delivered by Corning's in February 1967. The blank with total diameter of 3.72 m, of which about 3.6 m became the optically useful part, had been manufactured by fusing seven hexagonal pieces, plus the six triangular pieces to complete the circular form, as sketched in the drawing at the left. This formed part of a study of the disk by J. Texereau and J. Espiard, published in ESO Bulletin No. 2 of August 1967 (page 39). The photograph at right, presented to ESO by Corning, shows the positioning of the central hexagonal piece in the fusing procedure in December 1968 when a superficial flaw was eliminated from the mirror. From a set of photographs by Corning's in the EHPA.

able observers to obtain photographs with sharp definition of the stellar images in considerably larger fields. Essential in these solutions is, that just before reaching the photographic plate, which is placed in the focal plane of the Prime or Cassegrain focus, the light traverses a combination of lenses. By a suitable choice of their optical properties, in combination with a properly chosen figure of the mirrors – a choice made possible through the new computer techniques of the 1960's – optimal optical performance could be achieved. The principle of such a combination of reflecting and refracting elements was known as a Ritchey-Chrétien system after the names of the American and French opticians who developed it in Paris earlier this century. The combination chosen for the ESO 3.6-m is sometimes referred to as a Modified Ritchey-Chrétien or a Quasi Ritchey-Chrétien system.

For the extra reflecting components employed in the Cassegrain mode (one mirror) and in the Coudé mode (four mirrors), all of them sometimes referred to as "secondary optics", the blanks were ordered in 1966 from the firm of Heraeus-Schott in the German Federal Republic and delivered in the years 1968 and 1969. These also were made of Silica. Their figuring was included in the contract with REOSC and finished by them in the years 1970–1972.

By the time of the formal acceptance of the optical ensemble of primary and secondary mirrors, in 1972, the Telescope Project had become the respon-

sibility of the TP Division about which more will be written in the next article, but in the course of the preceding years the work on the figuring and testing at REOSC had been accompanied by a small group of experts on behalf of ESO, of whom I should mention especially A. Baranne and G.J. Monnet of Marseilles, D.J. Malaise of Liège, A. Behr of Göttingen and K. Bahner of Heidelberg-Königstuhl.

### The Mirror Cells

Between the optical system and the telescope tube there is an important interface: the mirror cells. In them, the mirrors are carried permanently and in such a way that deformation of their shape (which would result in deterioration of the stellar image) is avoided as much as possible. This is no small requirement if one realizes that during the motion of the telescope tube while it "follows" the star, the mirrors assume continuously changing tilts and orientations. The problem was particularly pressing for the large primary mirror. This has, as mentioned, a diameter of 372 cm, and an average thickness of about 50 cm and a total weight of 10,970 kg. (For detailed specifications see the article by Lemaître quoted before.) The mirror derives its rigidity from this thickness, but this is not quite sufficient.

On the other hand, there is a limit to the thickness because an increase of weight leads to rapidly increasing demand on the sturdiness of tube and

mounting and, hence, to rapidly increasing cost of the telescope. Compensation for the residual tendency to flexure of the mirror therefore was achieved by a support system placed under the mirror which acts through the force of gravity. It consists, for the ESO telescope, of a series of 30 concentrically placed and independently acting supports at the bottom side of the mirror, whereas at its sides the mirror is supported by three pads and a system of air cushions. Each of these 30 bottom supports is adjustable in itself but once the telescope is in operation, the supports cannot be adjusted from outside.

The design and manufacturing of the mirror cells was ordered from the firm of REOSC that also was to do the figuring of the mirrors. The reason is, that what is finally tested is the performance of the combination of mirror and cell as a unit. These combined units were delivered by REOSC in 1972.

At the moment this article is written, it is just in this domain of telescope design that a revolutionary improvement has been introduced: the "active optics" described in the *Messenger* of June 1989 and implemented in the New Technology Telescope. Modern techniques, including continuous computer control, have made it possible to abandon entirely the idea of rigidity of a mirror as achieved by its thickness. The solution towards the problem of obtaining optimal performance is found by taking advantage of a thin (and light!) mirror's flexibility and steadily controlling its



In (August?) 1968 the blank for the 3.6-m mirror arrived at the firm of REOSC in Ballainvilliers near Paris, for grinding and polishing towards its final shape. On the above photographs:

- upper left: arrival of the mirror blank in its crate at REOSC,
  - upper right: the crate deposited horizontally,
  - lower left: wooden packing material and the iron ring holding the mirror being removed,
  - lower right: first hand- and foot acquaintance with the mirror by (in the foreground) Charles Fehrenbach (left) and André Couder (right).
- From a set of photographs in the EHPA.

shape by a system of numerous and independent, but actively, from the outside adjusted supports. Twenty-five years ago, when Heckmann and his associates searched for the best support system for the ESO 3.6-m, this was undreamt of . . .

### Tube and Mounting; Strewinski's Pre-Design

Fehrenbach's summary of the recommendations of the IC by the time of the first Council meeting, in February 1964, also contained the following statement: "L'étude de la mécanique de l'instru-

ment devrait être fait par un bureau d'études indépendant, acceptant un marché d'étude." It confirmed the early intention of the ESO Committee to create a design bureau. In May of that year it had become clear that of the two engineers whose collaboration in the project was hoped for, the work for the large telescope would mostly involve Strewinski. According to Heckmann's report at the June 1965 Council meeting, a draft contract with the engineering bureau of Strewinski had been drawn up (but it is not clear whether it was ever signed). Ideas about the nature of the design were shaped within the IC, but

they were influenced strongly by suggestions of Strewinski.

Strewinski's design deviated in several important respects from that of large telescopes then in operation. First, note that the whole concept was still based on the classical model of a telescope moving around a polar axis (which is directed towards the celestial pole) and the declination axis, perpendicular to this. Of these two motions, only the first (and uniform) one is required during the telescope's following a star during observation. The radically different azimuthal design now employed for large optical telescopes was in use at that

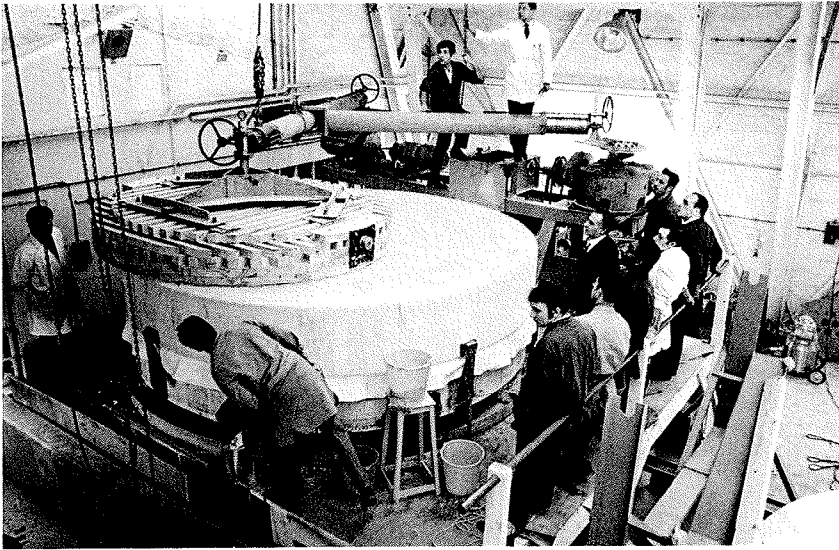

Shaping and testing the mirror at REOSC. Left: grinding the mirror (the large "white" disk) by means of the (smaller) rotating disk touching the upper surface of the disk. Among the spectators, the Director of REOSC, M. Baile (in dark jacket in front of the group at right). Right photograph: the optical laboratory of REOSC at which the shape of the mirror was tested. In order to do this with the mirror in horizontal position, REOSC built the high "optical tower" at right in the picture.  
 From a set of photographs provided by REOSC in the EHPA.

time only for large radio telescopes, and it was planned for (and later realized in) the 6-m USSR optical telescope in the early 1960's.

One of Strewinski's innovations concerned the storage of the optical elements which are alternately used for the different modes of operation. Whereas, for instance, at the 200-inch Palomar telescope those optical elements, which are not in use during operation in a particular mode, remain stored within the telescope tube, Strewinski proposed for the ESO telescope separate top ends of the tube carrying the different secondary mirrors, so that those not in use could be parked outside the tube in quickly interchangeable manner. An advantage of this solution was a reduction of the weight of the tube, and hence, simplification of the design and reduced costs of the mounting.

Another aspect of Strewinski's design was the combination of horse-shoe and fork mounting. In the classical mounting, realized, for instance, in the Lick 120-inch and also in the ESO 1-m and many other telescopes, the extremes of the declination axis rest in the extremes of the two prongs of a fork which forms an extension of the polar axis. For large telescope tubes, the top end of the fork which carries all the weight of the tube including the optical elements, is rather distant from the upper bearing of the polar axis, particularly so if the fork is made long in order to leave room for bulky equipment at the Cassegrain focus. This implies high demands on the system of bearings of the polar axis, and in the case of the ESO telescope especially so because at La Silla the axis makes an angle of 29 degrees only with

respect to the horizon. An impression of the weight we are dealing with may be obtained from the minutes of the 28th meeting of the IC, of May 1969, when the tube including the optics was estimated to weigh about 60 tons.

A different concept had been adopted for the Kitt Peak 150-inch telescope. Here, the bearings carrying the extremes of the declination axis rest in a very sturdy horse-shoe which in itself forms the upper bearing of the polar axis. Even without detailed knowledge of the forces acting on the bearing, one senses that for a heavy telescopes tube such a design is more suitable than a fork mounting. A solution like this was considered by Strewinski also for the ESO telescope. However, he rejected it in order to avoid the large diameter which would have been required for the horse-shoe, about 12 m. As Ramberg explained in his presentation of Strewinski's design at the April 1965 IAU Symposium, Strewinski feared "that it will be a fairly complicated matter, after having manufactured such a disk in Europe, to transport it to Chile and then take it up to the top of La Silla -- --" [4], and Ramberg mentioned this also at the December 1965 meeting of the IC.

### The Combined Horse-Shoe and Fork Mounting

This led Strewinski to his compromise solution: the combined horse-shoe and fork mounting. It is demonstrated in the accompanying drawing, taken from the presentation in the 1965 Symposium Report. Here, the declination axis is supported by two relatively short and very strong fork prongs mounted on the

horse-shoe disk. By this construction the diameter of the horse-shoe could be diminished to less than 8 metres. For the upper (horse-shoe) bearing Strewinski chose an oil bearing, the sliding surface of which is supported on two fixed pedestals, and in Strewinski's design the centre of gravity of the movable parts of the telescope is vertically above the midpoint of the line joining these two oil pads. Oil is constantly pumped at high pressure into the two sliding surfaces, so that during the operation the telescope floats on two thin films of oil. The sliding surfaces of this upper bearing were given a spherical shape, a concept Strewinski had earlier introduced for the Schmidt telescope of Hamburg Observatory.

Once these principal design characteristics had been agreed upon – and we do recognize them in the 3.6-m telescope as it has ultimately been realized – many details had to be worked out in close consultation between the bureau of Strewinski, the Directorate and the IC and its subcommittees. They met frequently in the year 1966 and thereafter. This led to the so-called pre-design studies and drawings in which specific solutions were formulated for the various technical problems encountered. Next should follow the exact designs required for the construction when the project would be in the hands of the manufacturer.

### Stagnation – and Growing Impatience

These pre-design studies and drawings were, however, produced at unexpectedly low rate by Strewinski's

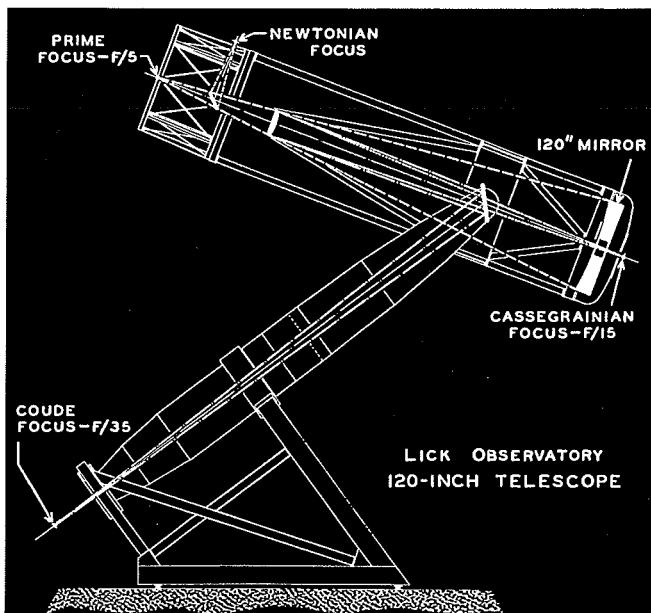

A sketch of the design of the 3-m telescope of Lick Observatory. In 1953, Walter Baade suggested that the principal telescope for the European Southern Observatory should be a copy of this telescope, which became operational soon afterwards. The sketch shows the telescope tube with its primary mirror of 3 metres and secondary mirrors for operation in the Cassegrain and Coudé modes. For motion in declination, the telescope tube rotates around an axis which is mounted at the top end of two long fork prongs; the fork forming the extension of the polar axis.

From: *Sky and Telescope*, March 1955, p. 176.

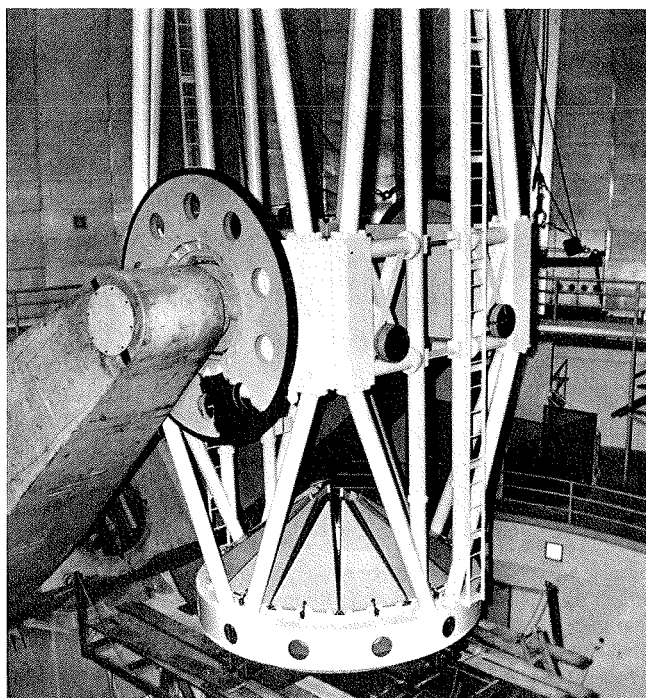

The Lick 3-m telescope when its mounting was virtually complete, in November 1954. The lower part of the telescope tube is shown, hanging on the declination axis at the top end of its long fork, the arms of which are about 7 metres long. The weight of the tube including the optics is about 40 tons (whereas the estimated weight for the ESO 3.6-m tube and optics was about 60 tons).

From: *Sky and Telescope*, May 1955, p. 272.



The engineer W. Strewinski (extreme left) visiting Observatoire de Haute-Provence in May 1966 with the ESO Instrumentation Committee and other specialists. From left to right next to Strewinski: Ch. Fehrenbach, O. Heckmann, a collaborator of Fehrenbach, A. Behr, A. Couder, M. Migeotte, and A. Baranne. Main features of the mechanical design of ESO's 3.6-m telescope and Schmidt telescope are due to Strewinski who had been engaged by ESO since soon after its creation. Early in the 1970's the ESO TP Division at Geneva took over for the realization of the 3.6-m telescope, as will be described in article IX; for the completion of the Schmidt telescope see article X. The photograph was taken on the roof of the Spectrographic Telescope Building-in-construction at Haute-Provence Observatory.

Photograph in envelope marked "Spectrographic Telescope" in the EHPA.

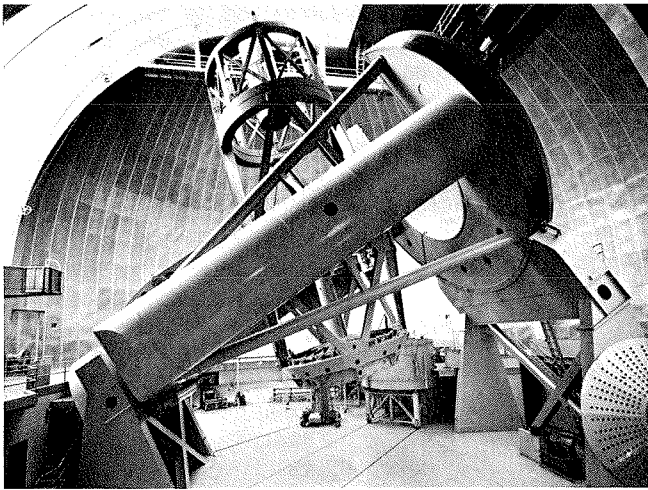

The 5-m Hale telescope of Palomar Mountain, shown here, had been in regular operation for four years when first talks about the creation of ESO took place in 1953. Its realization had taken many years due to interruption by World War II. The declination axis is positioned about half way between the south and north bearings of the polar axis so that the weight of telescope tube and polar axis is divided over the two bearings. The horse-shoe shape of the north bearing allows the telescope to observe objects near the north pole.

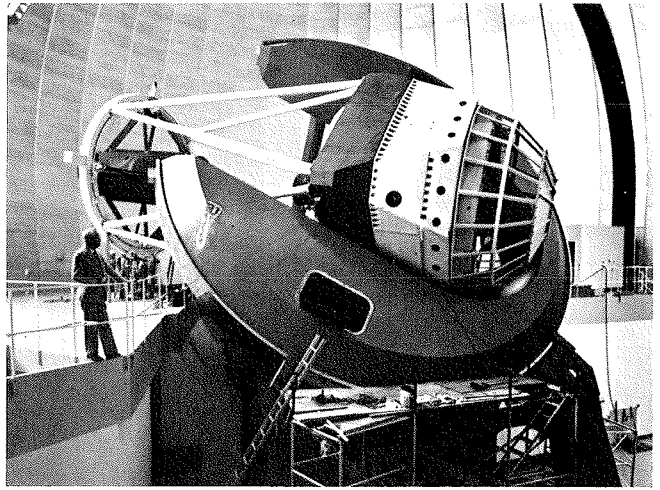

The 4-m Mayall telescope of Kitt Peak Observatory, which came into regular operation in 1974 after its creation had been initiated in the early 1960's by AURA. As in the case of the 5-m Hale telescope, the north bearing of the polar axis has the shape of a horse-shoe, but now the declination axis lies in the plane of the horse-shoe. This solution was considered for the ESO telescope, too, by Strewinski, but he preferred the solution described below in order to avoid the large diameter of the horse-shoe.

From *Sky and Telescope*, January 1973, p. 14.

bureau. The Directorate, especially Heckmann, in first instance kept full confidence in Strewinski to handle the task, but doubts began to grow among the IC and Council when a year after the Large Telescope symposium little progress was evident. In his report at the Council Meeting of April 1966 in Santiago (following the dedication of the road on La Silla), Fehrenbach felt compelled to state:

*"Il faut considérer que l'étude du grand télescope est arrivée au stade où il est nécessaire de penser à sa réalisation dans un délai raisonnable. Un certain nombre de membres de la C.I. m'ont indiqué, en privé, leur inquiétude concernant la méthode proposée.*

*D'après des informations, nos collègues américains prévoient un bureau d'études de 50 ingénieurs et techniciens, travaillant pendant plusieurs années pour l'étude complète de leur télescope de 3,75 m à Kitt Peak. Il est certain que l'organisation prévue par nous, c'est à dire un bureau d'étude réduit, par ailleurs chargé de l'étude du télescope de Schmidt, ne permet pas une réalisation dans un délai acceptable. Je me demande s'il ne vaudrait pas mieux passer la commande de la mécanique à une firme privée, le bureau d'étude de M. Strewinski restant organe de liaison entre cette firme et la C.I."*

Concern about the lack of progress in the pre-design continued to be expressed at meetings of Council and IC. A year later, at the June 1967 meeting of Council, it was agreed that "although the quality of Strewinski's work is excel-

lent, the capacity of his bureau is evidently too small ---. A solution would be to give the main part of the definitive design to a large firm which then could work under the supervision of Strewinski." However, suggestions to give part of the pre-design to an outside firm met strong opposition from the part of Heckmann, who emphasized "that the pre-design forms a unit; --- It would be a considerable loss of time to give the task --- to another firm, because no firm exists holding something like Strewinski's specific knowledge on the subject."

Again a year later, in the July 1968 meeting of Council, Fehrenbach on behalf of the IC reported that Strewinski was supposed to deliver the complete pre-design, drawings and descriptions, before June 1, 1968 but that this had been delayed due to the necessity for Strewinski to enter deeply into parts of the definitive design . . . In fact, the first part consisting of 34 drawings, mainly related to the telescope tube, was delivered only in November 1968 and extensively discussed by the IC in January 1969, whereas the second part, also 34 drawings, for the telescope mounting, was delivered in May 1969 and discussed by the IC in May and June 1969. As these three meetings were the last ones of the IC before the policy of Council was radically changed, and the creation of the Telescope Project Division of ESO was on the horizon – the IC would meet again only a year later, in June 1970 –, let me briefly describe the proceedings of those IC meetings in 1969.

## The IC Meetings in 1969

The meeting in January 1969 was almost entirely devoted to the design of the telescope tube. Items discussed were: technical solutions for the secondary mirror exchange when the observer changes his mode of observing; the stability of the position of the primary mirror during exchange of top parts of the tube, when the mirror is in vertical position; the interchange of equipment used at the prime focus; the design of the mirror supports; specifications and design of the Cassegrain cage; and the design of the drive system. Items taken up in May 1969 were: the (very important!) question of the flexure of the fork prongs in different positions of the tube; the design of the south (upper) bearing and the safeguard against earthquakes; the choice of the (mechanical?) drive system; the control of "mirror 5" of the Coudé system.

During the second part of this meeting, a small ad-hoc group consisting of Strömgren (as Chairman), Fehrenbach, Heckmann, Ramberg and Strewinski convened separately. It subsequently reported to have found Strewinski's pre-design sufficiently advanced that preliminary steps might be taken towards the implementation of the project, and it suggested names of firms to approach for first contacts. Strewinski would be supposed to continue the detailed design work but should rather not be involved in shop-drawings unless he would increase his staff by 10 to 15 engineers and draftsmen. A time

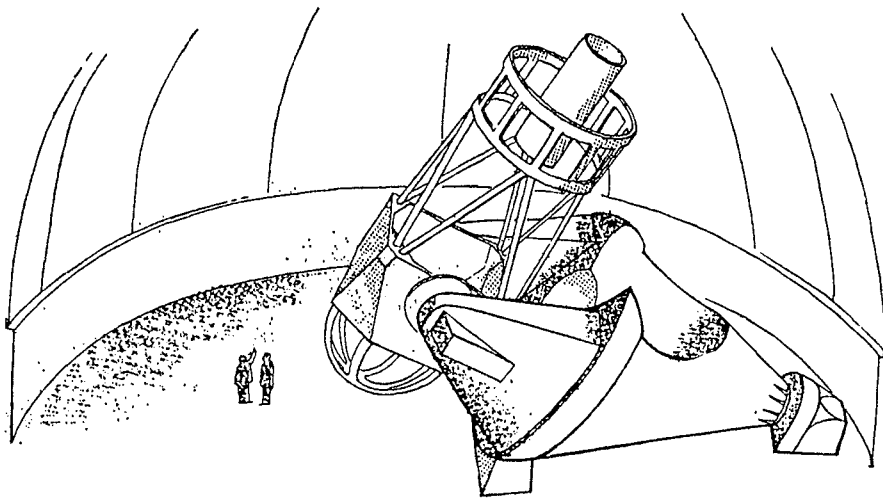

The design for the ESO 3.6-m telescope as presented by Strewinski at IAU Symposium No. 27 on "The Construction of Large Telescopes" in April 1965. In order to reduce both the length of the fork arms as required for the Lick 3-m telescope design, and the large diameter of the horse-shoe as realized in the case of the Kitt Peak 4-m telescope, Strewinski proposed the combined fork and horse-shoe solution shown here. Another feature of his solution was a spherical shape for the horse-shoe bearing, and positioning the centre of gravity of telescope plus polar axis vertically above the line joining the two oil pads which carry this bearing. From *The Construction of Large Telescopes*, IAU Symp. No. 27, Ed. D.L. Crawford, 1966, p. 118.

schedule was proposed for the ordering of parts: for the period October 1969 to April 1970 these should include the main parts of the mounting, and subsequently, until October 1970, the main parts of the telescope tube. In a third period, until April 1971, the ordering of the telescope drive and mirror support systems were foreseen. Presupposition would be that Strewinski would settle for this time-schedule contract. Strewinski himself recommended collaboration with a local firm.

However, doubts were expressed – particularly from the part of S. Laustsen (about whose role in the project we will see more below) – whether the time schedule was realistic: "An efficient group of astronomers and engineers is necessary for the planning and coordination of the whole 3.6-m project and for the design studies and development work bearing on control and automation" [5].

In the June meeting, four weeks later, aspects of the design of the Cassegrain cage and the Coudé mirror system were reviewed, after which Heckmann globally summarized still pending matters: mounting of the Coudé mirror; Cassegrain cage; facilities for optical adjustments; mirror support systems; prime focus correctors and plate holders; drive system; encoders; computer control interface. However, no decision was taken with regard to a recommendation to Council for entering contacts with construction firms as had been suggested at the May meeting. A next meeting of the IC was scheduled for October 1, 1969, but not held.

As described in my previous article, around this time – the middle of 1969 –, dissatisfaction about the lack of progress was one of the reasons for creating the Working Group of Alline, Funke and Scheidemann. A worried Council considered alternative ways to realize the telescope, and the role of Strewinski's bureau was more and more confined to the completion of the Schmidt telescope. We shall come back to the Schmidt in article X, and before entering the description of the new approach in the 3.6-m telescope project, review what had been done on the design of the telescope building and dome and in the field of automation.

### The Building

Once the main properties of the telescope had been fixed, steps were taken toward the design of building and dome. At its November 1966 meeting, Council, at Heckmann's request, agreed that this project should be handled separately from the building projects of the first stage of which we described the dedication in article VI. In order to allow close consultation, a civil engineering firm in Hamburg was chosen, Lenz Architekten & Ingenieure. Their architect Mr. Mix gave a first report at the IC meeting of December 19, 1967. From the minutes of this meeting [6] main features of the design can be inferred, but unfortunately no drawings have so far been located in the ESO files. A basic feature of such a telescope building is its consisting of two parts on separate foundations: part A for the support of

the telescope and its auxiliary equipment such as spectrographs, and part B supporting first of all the heavy rotating dome, but also serving for electronic laboratories, dark rooms, storage space, laboratories, aluminizing facilities, air conditioning, elevators, etc. Reason for this separation of structures is that no vibrations caused by the activities in part B should be transmitted to the telescope and its auxiliaries of part A (for instance those caused by the rotation of the dome).

An important feature of structure A for the 3.6-m Telescope was a large floor below the observing deck for the erection of the Coudé spectrographs; these, together with the size of the dome, became the determining factor for the horizontal extension of the building. A length of 24 metres for the Coudé light path figured in early planning, but was reduced to 18 m at most by November 1966. The diameter of the dome was estimated to be 28 metres [7]. Throughout the designing by Lenz, the result of the special requirements for the Coudé floor was a building of rectangular shape which risked to have a deteriorating effect on the image quality in the telescope.

Another basic measure was, of course, the height of the telescope above ground level. This was defined as the height of the crossing point of declination axis and polar axis, and fixed at 24 metres. The decision to put the telescope that high goes back to the results of measures of image quality at different heights above ground level by the method of Siedentopf described in article II, for which data had been obtained by André Muller over a long period by means of high masts, one of which was erected at the highest summit of La Silla. Note that it was this element, the required image quality, that determined the height of the building, not the need of space for housing the various facilities.

Of the many other aspects of the design, let me mention only the important problem of providing proper heat insulation in order to avoid heating up of the inside of the dome during day time.

In the July 1968 meeting of Council, Ramberg could report that the firm of Lenz expected to finish the pre-design by the end of that month, and in the December meeting first steps for a building contract were discussed. However, the delay in the design of the telescope kept Council and Directorate from taking this further step towards realization. Coordination of construction activities on La Silla with those for the building of the 4-m telescope on Cerro Tololo was discussed with AURA in Santiago in March 1969 [8].



## The Dome

Simultaneously with the planning of the building, preparations were made for the design of the dome. Favourable experience had been gained with the firm Seibert-Sécometal at Saarbrücken, that had provided the domes for the first construction phase. This early work had been supervised by their engineer W. Bauersachs, who has described it in *ESO Bulletin* No. 4 of July 1968 (and who years later joined the staff of ESO). Hence, this firm was now also charged with the design and construction of the dome for the 3.6-m telescope. This was finished by the end of 1968, and so this project, too, was ready for tendering in 1969.

## Automation in Telescope Control

Among the many valuable experiences of Fehrenbach and Heckmann during their visit to observatories in the United States in 1962 was the confrontation with new, electronic computer techniques for the control of telescope functions. This rapidly developing field was also energetically pursued in the ESO member states and led to a document "Some Suggestions for Automation of the 3.6-m Telescope" issued by the ESO Directorate in February 1968 under supervision of the Technical Director Jöran Ramberg [9]. The authors included two young astronomers, F. Dossin of Liège who had joined the office of the Director in February 1966, and S. Laustsen of Copenhagen Observatory who acted as consultant to the Directorate.

Main functions of the automation as listed in the document and elaborated in detail were: A) Automatic Control: setting of the instrument, telescope driving, dome and shutter operation, setting and driving of siderostate, and "local driving", and B) Semi-automatic operations (push-button control). The new concepts were discussed in a series of meetings: in February 1968 in Paris, in September 1968 in Karlsruhe at the firm of Siemens (in view of a collaborative project with this firm) [10], and at the IC meetings of November 1968, and May and June 1969.

Meanwhile, Svend Laustsen had become a staff member of ESO per September 1968, in order to assist the Directorate in matters of automation of telescope operation and for the development of a programme for auxiliary instrumentation for the 3.6-m telescope. Gradually, an in-house working group was formed headed by Laustsen, which by the end of 1969 also included the astronomical technician B. Malm and the electronics engineer M. Blichfeldt,

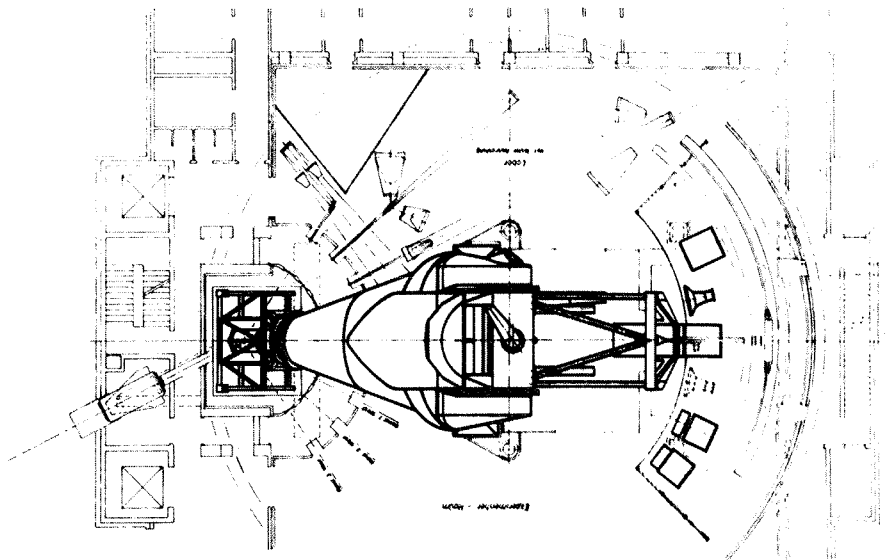

*The drawing reproduced here is part of a set of drawings made by the bureau of the engineer Dr. W. Strewinski and marked "Gesamtanordnung" and "Stand 18-10-1968". This set of drawings was reproduced in Document Cou-59, written by ESO's Technical Director J. Ramberg for the Council meeting of December 1969 and entitled "The Present State of the 3.6 m Telescope Project". This section of the drawings shows the arrangement proposed by Strewinski for the storage of the different top-ends of the telescope tube which carry the secondary mirrors for use in different modes of operation.*

*The proposal led to the more detailed design by the TP Division shown in the sketch below. We also note, albeit vaguely, in this drawing the square contour of the telescope building extending beyond the projection of the dome, a design that followed from the large space that was deemed necessary for the long optical paths in the Coudé spectrographic equipment. The design of the final, cylindrical, telescope building on La Silla represents a radical change, introduced in the early 1970's.*

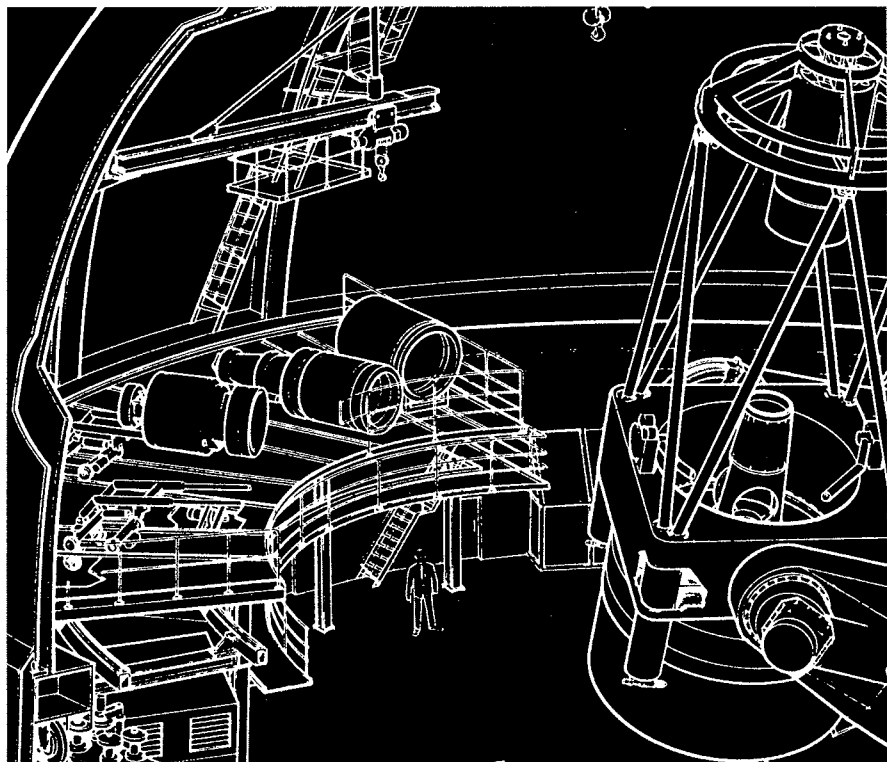

both also from Denmark. It continued to grow in 1970 and would become the nucleus of the 3.6-m Telescope Division, the creation of which we shall describe in the next article.

Whereas in the early phase of ESO, the three telescopes, 1-m, 1.5-m, and

the Schmidt, as we saw in article IV, could be identified with the specific interests of institutes in the Netherlands, France and the German Federal Republic, respectively, it now had become Denmark's turn by providing this nucleus.

## References and Notes

Abbreviations used:

EHA = ESO Historical Archives (see *The Messenger* of December 1988).

FHA = Files Head of Administration at ESO Headquarters.

EHPA = ESO Historical Photographs Archives.

Heckmann Sterne = O. Heckmann, *Sterne*,

*Kosmos, Weltmodelle*, Verlag Piper and Co., München–Zürich, 1976.

[1] Wykeham Publications Ltd., London–Winchester 1975.

[2] Heckmann Sterne, p. 323.

[3] For reports on work by Baranne, Köhler, and Paul of the years 1962 and 1963, see EHA-I.C.1.9.m.

[4] See page 118 of the Symposium Report.

[5] FHA, Minutes 28th meeting of the IC, p. 9/10.

[6] FHA, Doc. IC-26 = BG-16.

[7] FHA, Doc. IC-18 = BG-15.

[8] FHA, Minutes of the 12th Cou Meeting, p. 13.

[9] FHA, Doc. IC-24.

[10] For reports of these meetings, see FHA Docs. IC-27 and IC-29.

# Observations of Visual Double Stars at La Silla

M. SCARDIA, *Osservatorio Astronomico di Brera, Merate, Italy*

## Introduction

Of the many types of observing programmes made at La Silla with the most sophisticated equipment provided by modern techniques, one in particular distinguishes itself because it utilizes for the observations only the human eye, the oldest and most traditional of detectors used in astronomy. This research is the micrometric observation of visual double stars.

The concept of a visual double star is a relative one: by a visual double star we mean the whole of two or more stars, angularly close, which can be distinguished from each other through the eyepiece of the telescope. It is then evident that, when increasing the diameter of the telescope, ever more narrow double stars should become visible as distinct objects. However, there exists a lower limit, introduced by the earth's atmosphere, which is of the order of 0".1. This limit to visual observations can sometimes be overcome by observers of great experience, on sites of particularly good seeing (Couteau, 1987).

The astronomy of visual double stars is by now over two centuries old. In 1778, W. Herschel, following one of Galileo's ideas, began systematic observations of visual double stars with the purpose of determining stellar parallaxes. He did not manage, comprehensively, to determine any parallax, because the quantities to be measured were too small for the coarse micrometers of that period, but in 1803, with a publication that has made history (Herschel, 1803), he proved that physical binary stars were a reality and that the law of universal gravitation was valid also outside the solar system.

More than 600 astronomers after Herschel have measured visual double stars with various techniques, leaving a patrimony of about 1,000,000 individual measurements, summarized for practical purposes in over 410,000 annual averages.

This enormous task of observation has led to the discovery of over 70,000 double visual stars in the entire sky, of which about 900 have today a known orbit.

The history of the visual double star astronomy is a fascinating chapter in the history of Astronomy; for those who would like to examine it more closely, there are many articles and books that deal with it in detail (Baize, 1930 – Heintz, 1978 – Couteau, 1988).

## The Method

The first "modern" measurements, by quality and accuracy, date back to 1828, and were made by F.G.W. Struve who used a refractor with a diameter of 24 cm at Dorpat in Esthonia. It was built by J. Fraunhofer and was at the time the greatest and the first conceptually modern instrument in the world. Struve discovered and measured 3134 double stars on the basis of a specific research programme.

We also owe to Struve the method of measurement of separations with the filar micrometer, known as the double distance method, commonly utilized even nowadays. The filar micrometer (utilized for over 80% of visual measurements) is a very simple instrument: it is made up of a reticle of spider threads, placed in the focal plane of the telescope, two of which are fixed and perpendicular to each other. The third is mobile (by means of a micrometric screw) and is parallel to one of the fixed lines. The entire device can rotate around the optical axis of the telescope (Fig. 1).

The measurement of a visual double star consists in the determination of three fundamental parameters:

(a) the date of observation expressed in years and decimal fraction;

(b) the position angle  $\vartheta$ , or the angle between the line that connects the two stars and the north direction, taking as

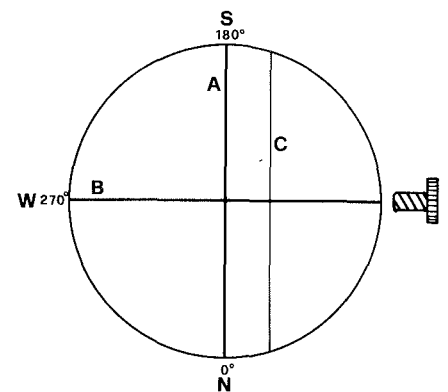

Figure 1: Scheme of a filar micrometer: A and B are fixed wires, while C is the mobile wire whose movement is commanded by the rotation of the micrometric screw.

the origin the "main" star (usually the brightest) (Fig. 2);

(c) the separation  $\rho$  between the two stars, expressed in arcsec (Fig. 3). For this it is necessary to know the scale of the instrument in arcsec/mm.

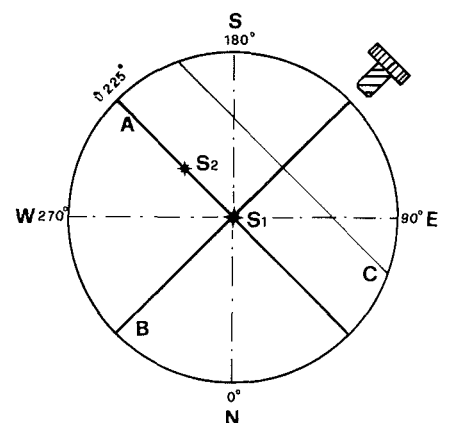

Figure 2: The measure of the position angle  $\vartheta$  is made by rotating the micrometer around the optical axis of the instrument so that the fixed wire A bisects the two stars S1 and S2. The most luminous star S1 is, by custom, considered the principal star and is chosen as the origin of the coordinates.