

J.P. Gaffard (CGE), P. Kern (Obs. de Meudon), P. Léna (Obs. de Meudon), J.C. de Miscault (CGE), G. Rousset (ONERA), and to many colleagues at ESO for stimulating discussions.

References

For additional references the following papers are recommended:

- F. Merkle (1988), "Adaptive Optics Development at ESO", Proceedings of the ESO Conference on "Very Large Tele-

scopes and their Instrumentation", Garching 21-24 March, 1988.

- P. Kern, P. Léna, G. Rousset, J.C. Fontanella, F. Merkle, J.P. Gaffard (1988), "Prototype of an adaptive optical system for infrared astronomy", ref. as above.
- F. Merkle (1988), in SPIE Proceedings 1013: "Optical Design Methods, Applications and Large Optics", Hamburg, F.R.G., September 1988.
- P. Kern, P. Léna, J.C. Fontanella, G. Rousset, F. Merkle, J.P. Gaffard (1989) in SPIE Proceedings 1114: Symposium on "Aerospace Sensing", Orlando, Fl, March 1989.

LATEST NEWS

IR Observers at the 3.6-m telescope are informed that the new F/35 chopping secondary mirror is now available.

The F/35 chopping secondary mirror was reinstalled in August 1989 and tested with the IR Photometer/Spectrophotometer. The performance of the system proved at least identical to the one quoted in *Messenger* 39, 1, 1985. ESO's IR Specklegraph (see *Messenger* 45, 29, 1986) was also successfully used in its F/35 configuration.

A. van Dijsseldonk (ESO)

Telescope Alignment Procedures: Improved Technique in the Optical Identification of Mechanical Axes

P. GIORDANO, ESO

Introduction

In the article concerning "First Light" in the NTT in the *Messenger* No. 56, a brief description was given on page 2 of the basic steps of the alignment procedure. As was stated there, the procedure used in the NTT was essentially only a somewhat more refined form of a standard procedure which had been successfully used on a number of La Silla telescopes. The first - and most fundamental - step is the optical identification of the altitude axis (alt-az telescopes) or declination axis (equatorial telescopes).

The set-up for this step in the NTT is shown in Figure 1. ST1 and ST2 are two sighting telescopes mounted at the two Nasmyth foci. Target mirrors tM1C1 and tM2C2 were mounted on the fixed parts of the fork. The observation of a central cross on these target mirrors and the observation of the ST graticule in auto-collimation against the plane faces of the target mirrors enables the two ST to be placed on the mechanical altitude axis, thereby establishing a basic reference for the whole operation. However, space reasons dictated in this case that one had to "look through" tM2C2 to observe tM1C1 with ST1 and conversely with ST2. The conventional solution using "half-coated" mirrors leads to loss of $\frac{3}{4}$ of the light and ghost images with higher intensity than the required images.

The selected solution was based on the combination of narrow band dielectric mirrors and illumination of the sighting telescope with the corresponding light using narrow band interference filters. We get in ST1, for example, a maximum of reflectivity from M2C2, in spite

of 2 passages through M1C1 (see Fig. 1).

The wavelengths chosen in the realization of the 2 beams were in accordance with the laser light currently used in our laboratory:

Red beam $\lambda_c = 632,8 \text{ nm}$ HeNe laser
Green beam $\lambda_c = 543,5 \text{ nm}$ HeNe laser

Realization

The dielectric mirrors were realized and delivered on time by MELLES

GRIOT (France), who, after a first study and a computer simulation, achieved in practice an excellent confirmation of the theoretical values. The front surface, with the cross-hair, is coated with the dielectric layer, while the back surface is coated with a broad band antireflective coating.

The interference filters were selected carefully from the ESO La Silla catalogue, in order to optimize the total efficiency of the delivered version of the dielectric mirrors.

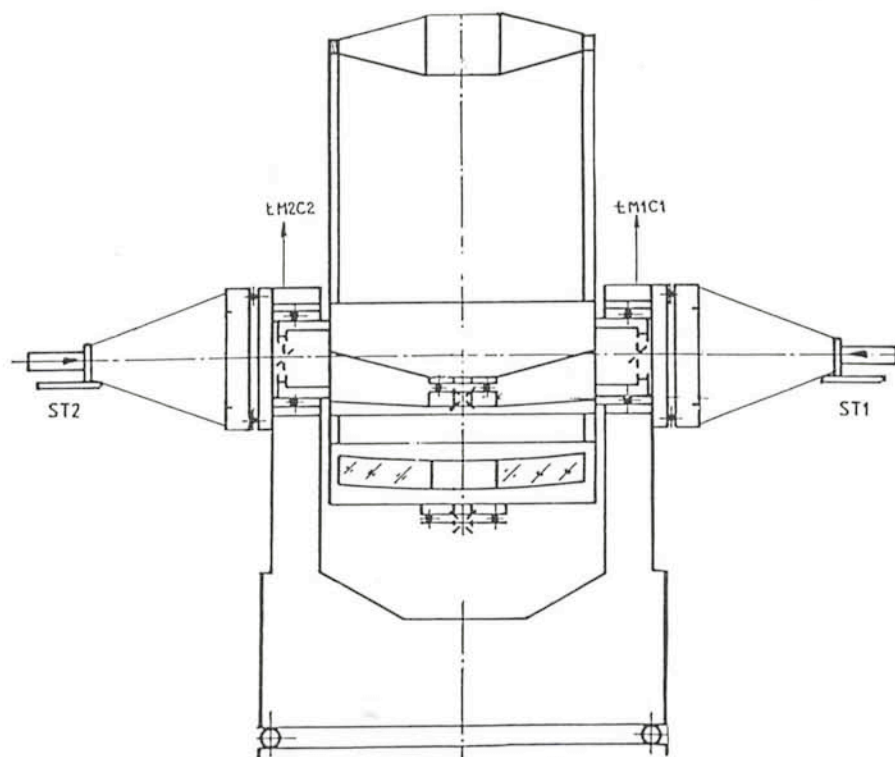

Figure 1.

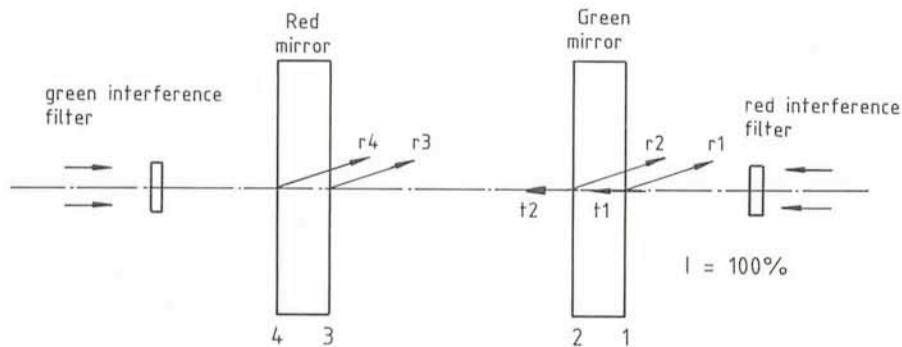

Figure 2: Schematic diagram. Please note that the numbering is in accordance with the direction of the light. In this example, the light enters from the right-hand side.

Figure 2 shows how the system functions. Surfaces 2 and 3 are coated. In a non-absorbing material the energy con-

servation formula is $r + t = 1$ and the transmitted amplitude is given by $t = 1 - r$.

The main objective of this design was

to obtain the highest ratio of image intensities reflected by surface 3 with respect to surface 2. In the "classic" case of half coated mirrors, this ratio has a very low value of 0.25. Our new arrangement (red dielectric mirror used at 646.6 nm) achieves a ratio of 37.2, about 150 times higher! In the second case (green dielectric mirror), using an appropriate narrow filter, we could achieve a value of 2.4, a gain of about 10 times. However, with a filter operating at a slightly shorter wavelength, which was not available at that time, a value of 10.5 would be achieved, a gain of about 40 times. A small harmonic leak was the reason why the green case was somewhat less efficient than the red.

EFOSC2

W. ECKERT, D. HOFSTADT, J. MELNICK, ESO

Late in 1987 it became clear that, before the implementation of the ESO Multi Mode Instrument (EMMI), the NTT would require an optical instrument with imaging and spectroscopic capabilities.

To build a second EFOSC was a logical choice in view of its moderate size and above all, the possibility of retrofitting the instrument later on at the 2.2-m telescope. EFOSC is in high demand at the 3.6-m telescope where it caters for nearly one-third of the observations and

a similar potential use exists at the 2.2-m.

The initial idea was to build a copy of the present version but it soon became evident that a new mechanical design was required to adapt different optical scales and to allow for a larger detector format. It was also clear from our experience with the 3.6-m version that a number of improvements were desirable, particularly for the setting and handling of the optical components.

While the basic configuration layout was maintained (see Fig. 1), the intention was to acquire optical components with an improved blue transmission. Early in 1988 a contract was placed with the Swiss firm FISBA Optik for the delivery of the camera, collimator and field lens units within 6 months. Figure 2 shows the overall response curves for the three components combined. It compares favourably with the optical transmission of EFOSC. Since the final

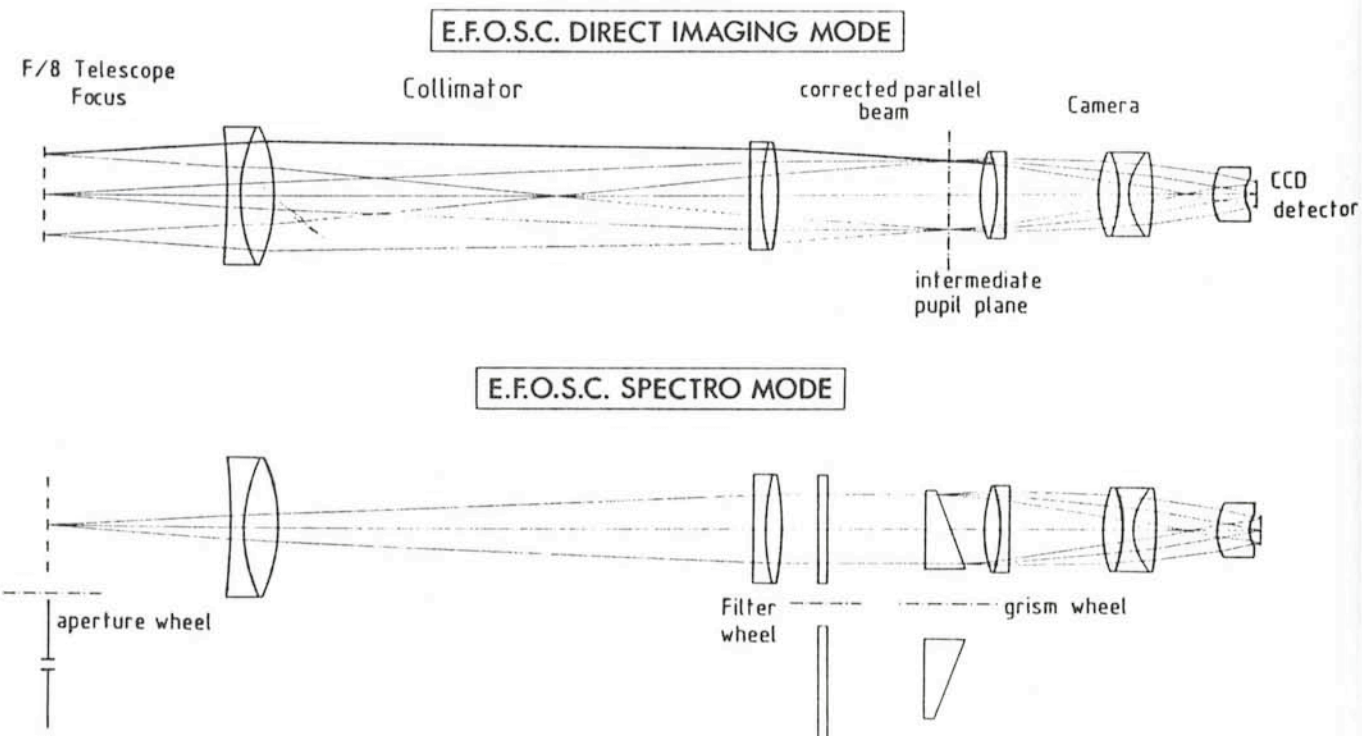

Figure 1: Optical Layout of EFOSC 2.