

Stereo-SCIDAR: Instrument and First Commissioning Results

Frédéric Derie¹
 Richard Wilson²
 James Osborn²
 Marc Dubbeldam²
 Marc Sarazin¹
 Robert Ridings¹
 Julio Navarrete¹
 Miska Lelouarn¹

¹ ESO

² Department of Physics, University of Durham, United Kingdom

The vertical distribution of atmospheric optical turbulence has a significant impact on the performance of wide-field adaptive optics systems. Stereo-SCIDAR is an instrument capable of measuring the vertical profile of the turbulence strength and velocity with high sensitivity and altitude resolution. Stereo-SCIDAR, developed in close collaboration with Durham University, was successfully tested at the La Silla Paranal Observatory in mid-2016. This visitor instrument is located at the coudé focus of one of the Auxiliary Telescopes and will record atmospheric turbulence profiles above Paranal for one year starting in October 2016. These measurements are required for the specification and implementation of adaptive optics for the European Extremely Large Telescope.

Limited statistical data, with high vertical resolution, exists for the optical turbulence strength and velocity profile above the Paranal Observatory. Recently, the University of Durham proposed an extended campaign to obtain more complete statistical data, relevant to the implementation of adaptive optics at Paranal and Armazones, through the operation of a new SCIDAR (SCIntillation Detection And Ranging) system at a coudé focus of one of the Auxiliary Telescopes (ATs) of the Very Large Telescope (VLT).

A SCIDAR is a type of instrument that measures the optical atmospheric turbulence profile using a “crossed-beam” technique, by observing double stars. A SCIDAR system was previously deployed at Paranal for a successful campaign in

2008, in the form of the Cute-SCIDAR instrument of the Instituto de Astrofísica de Canarias (C-SCIDAR: Vásquez Ramíó et al., 2008).

The Centre for Advanced Instrumentation (CfAI) at the University of Durham has developed a new variation of the SCIDAR profiler. Stereo-SCIDAR (Shepherd et al., 2014) makes use of separate, synchronised, low-noise detectors for each component of the double star target, whereas in previous SCIDAR instruments the light from the two stars was superposed on the same detector. Separating the light from the two stars enhances the sensitivity for turbulence profiling and facilitates automated profiling of the turbulence velocity. It also increases the sky coverage of the instrument as larger brightness differences between the two target stars can be tolerated. Operation of the Stereo-SCIDAR instrument is largely automated and will require limited Telescope and Instrument Operator (TIO) support only, an essential requirement for an extended observing campaign. Observations with the instrument are possible under a wide range of seeing conditions (up to seeing values of at least 1.5 arcseconds) and the turbulence profile and wind velocity data are available in near real time.

Objectives and performance requirements

The overall scientific goal is to provide a statistically representative database of the turbulence profile required for adaptive optics (AO) development at the VLT and the European Extremely Large Telescope (ELT). Accurate modelling for the advanced AO systems of the ELT and, in particular, for tomographic systems, requires statistical data for the full vertical profile (up to approximately 20 kilometres) with high resolution. The main concern is the conditions at higher altitudes, above ~ 1 kilometre, which are less affected by local orography than the ground-layer turbulence.

Under the hypothesis that data obtained from observations at Paranal are representative of the ELT site at Armazones, 30 kilometres distant, ESO decided to install the Stereo-SCIDAR optical turbu-

lence profiler instrument at a single coudé focus of one AT. Operation of the SCIDAR on a 1.8-metre AT will provide profiles of the optical turbulence strength and wind speed with a vertical resolution of approximately 300 metres or better, to a maximum altitude of around 20 kilometres. Cross-comparison of the SCIDAR output with existing instruments on site (Multi-Aperture Scintillation Sensor [MASS], Differential Image Motion [DIMM], SLOpe Detection And Ranging instrument [SLODAR], AO telemetry, etc.) will be an important aspect of the project.

The typical required performance and environmental conditions of Stereo-SCIDAR are summarised here. The parameters to be measured are the optical turbulence strength profile $C_n^2(h)dh$ and the turbulence speed and direction $V(h)$ profile at a sampling rate of one minute. The parameters to be computed/displayed are the isoplanatic angle (θ_0) and the temporal coherence scale (τ_0). The sequence acquisition time is required to be 3–5 minutes for telescope preset and the typical observation time per target is 2 to 4 hours, thus 2–5 targets can be measured per night. The telescope preset and open-loop tracking accuracy/stability needs to be 5 arcseconds on sky (peak-to-valley) in seeing conditions up to 1.5 arcseconds. Stereo-SCIDAR is required to operate about 4 nights per month over an operational period of one year. Targets should be (optical) double stars with separations in the range 10–20 arcseconds where each component has V mag ~ 7.0 or brighter. The double star needs to be visible over the whole observing session of 2–4 hours and the declination range of targets is –60 to 0 degrees.

Planned test campaign

In order to obtain statistically valuable information about the full vertical profile, ESO decided to conduct a one-year test campaign with Stereo-SCIDAR. The instrument will be operated on a few nights per month over observing periods 98 and 99. Stereo-SCIDAR runs will coincide with the VLT Interferometer Unit Telescope (UT) runs for which the ATs are not required. A high degree of automation of the instrument, long observation runs

on the same target and good tracking of the telescope in blind mode will greatly simplify the operation. But for safety reasons the telescope and instrument will be operated and supervised by a TIO. As for all instruments, the data (in this case the turbulence profiles) will be archived at ESO following the standard procedure. The subsequent data reduction to prepare for science publication will be done by the University of Durham.

Instrument design

The dual-detector approach of Stereo-SCIDAR has advantages over the conventional approach, specifically increasing the signal-to-noise ratio of the recovered turbulence profile by a factor of ~ 2–20 depending on the differential brightness of the two target stars. The two-camera system can therefore detect weaker turbulent layers. The vertical resolution of the profile is improved and a larger number of useable target stars are available. Furthermore, measurement of the turbulent layer velocities is simpler with the two-camera approach, so that wind velocities can be calculated in real time, even for weak layers.

The Stereo-SCIDAR instrument comprises two major sub-systems. The first is the instrument located at a coudé focus of the AT and consisting of:

1. a dedicated support structure (UROS) for the SCIDAR instrument;
 2. a custom mechanical interface between UROS and SCIDAR, providing tip-tilt adjustment of the instrument;
 3. a focusing mechanism and controller common to both image planes;
 4. instrument (de)rotator mechanism and controller common to both image planes;
 5. focal-plane optics featuring a charge coupled device (CCD) detector (Andor Luca-S 658M EM-CCD) for each image plane (Peltier cooled so no cooling liquid is required);
 6. an off-axis camera system to assist with target acquisition and tracking;
 7. local control computer (for camera control and data acquisition, rotator mechanism control, and focus control).
- The second sub-system is located in the VLT computer room and consists of a

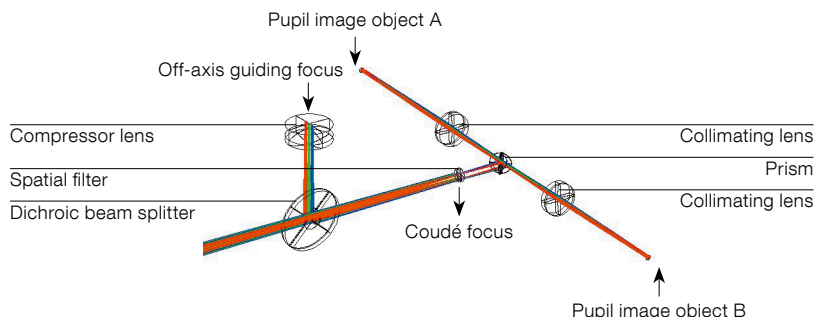

Figure 1. Schematic of the optical design of the Stereo-SCIDAR instrument.

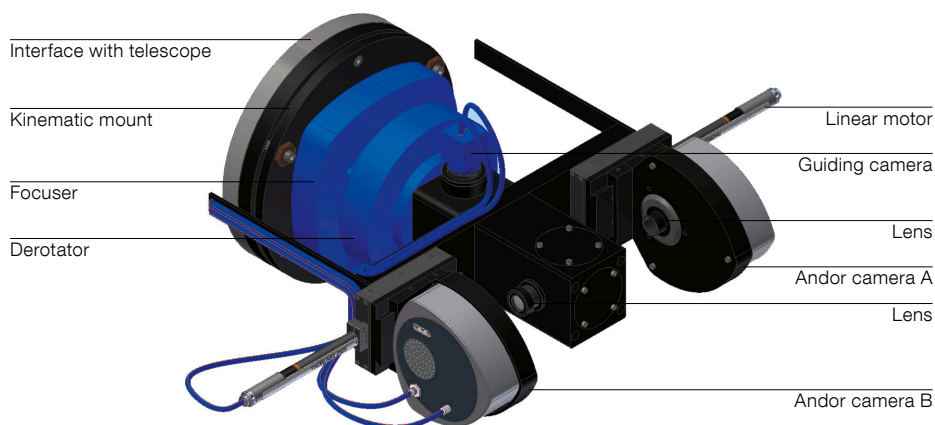

Figure 2. Mechanical design of the complete Stereo-SCIDAR focal plain instrument.

supervisor workstation for real-time data analysis and display.

The optical design of Stereo-SCIDAR is very simple (see Figure 1): the only powered optical component is a collimating lens in each arm of the instrument. A reflecting (coated) right-angle prism directs the light from each component of the double star onto a separate detector. In each arm, the telescope entrance pupil is re-imaged onto the detector by the collimating lens. Each detector is mounted on a motorised stage for accurate positioning (along the optical axis) at the pupil image (or slightly away from it, to re-conjugate the observing plane effectively below the telescope level). A dichroic beam-splitter feeds an additional camera for target acquisition and guiding.

Mechanical layout

The interface with the telescope is made by a kinematic mount, consisting of two circular plates, which provide tip-tilt and focus adjustment of the entire instrument by means of a “push-pull” type mechanism. Figure 2 shows a view of the mechanical layout. The adapter plate provides a dovetail-style mounting interface for a heavy-duty Atlas focuser, manufactured by Finger Lakes Instrumentation. This stepper-motor-based focuser enables the instrument to accommodate shifts in telescope focus between observing runs.

An Optec Pyxis 3” Camera Field Rotator is attached to the focuser by means of a custom-made dovetail-style mounting

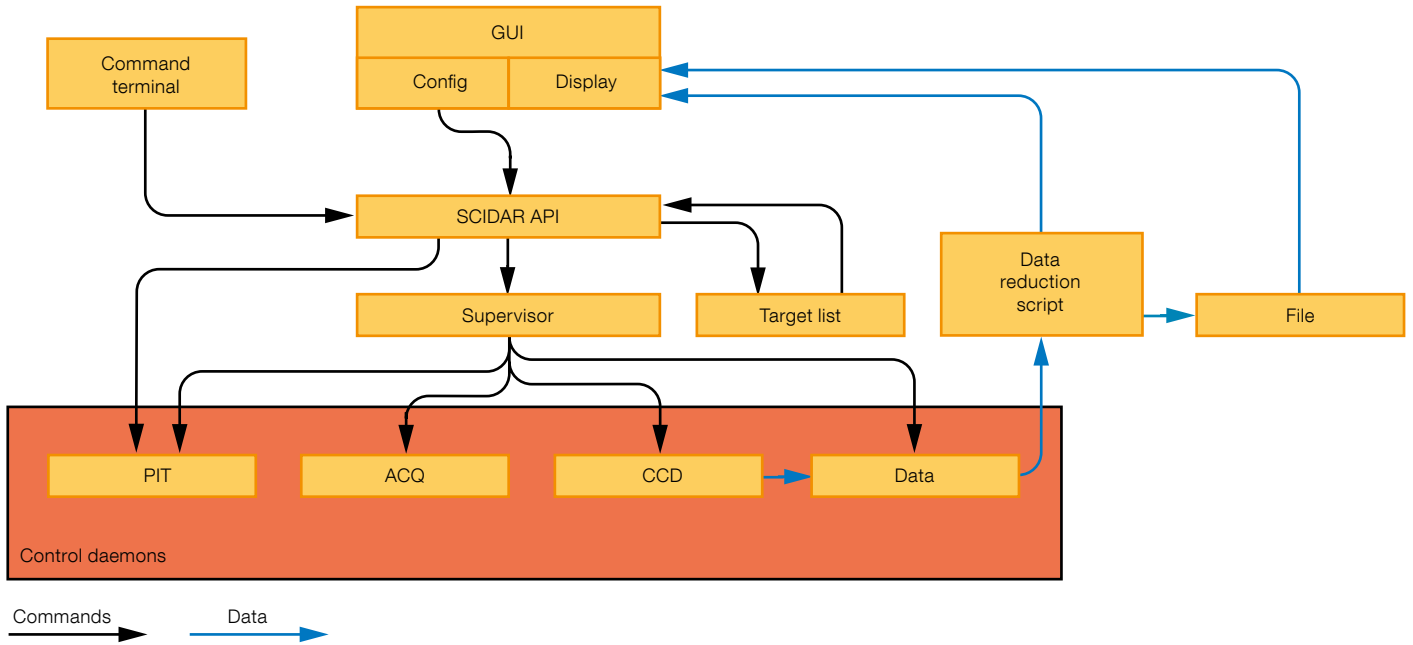

Figure 3. Schematic illustration of the structure of the Stereo-SCIDAR control software.

adapter. This stepper-motor-driven rotator is used to rotate the instrument to align it with the orientation of the binary star on the image plane, such that both components are centred within the rectangular aperture of the spatial filter. In addition, the rotator is used to track rotation of the field during an observation. Closed loop feedback is provided by the off-axis camera.

The main structure of the instrument is formed by the front cube which is attached to the rotator by means of a custom-made flange. The front cube features mounting ports for the dichroic beam splitter and the off-axis camera. This camera is attached to a lens barrel by means of a custom-made dovetail-style mounting flange. The compressor lens is also mounted inside this lens barrel by means of a threaded retaining ring. The distance between the lens and the detector surface is fixed. The use of the dovetail mounting flange then allows the orientation of the camera to be adjusted independently of focus, such that the aperture of the spatial filter is aligned with the long edge of the detector.

Control software

The software package is built around four daemon processes that run in the background (see Figure 3). These daemons initiate, monitor and control all of the instrument devices and processes:

- ccd_daemon — to control the two Andor Luca EMCCD cameras;
- acq_daemon — to control the Point-Grey Blackfly acquisition camera;
- pit_daemon — to control the rotator, focuser and actuator mechanisms;
- data_daemon — to process the SCIDAR raw data into turbulence profiles.

A supervisor script runs on the supervisor personal computer (PC) in the telescope control room. This script monitors the status of the system as a whole, gathering data returned from the daemons and displays these data to the user.

An interface script allows the user to control the SCIDAR system via a small

number of commands, entered on the command line of the supervisor PC. These commands, for example to start or stop data acquisition, are checked and then passed on to the relevant daemon. The software is designed so that the instrument is as automated as possible and the following utilities are automated: rotation; focus; pupil conjugation; region of interest selection; gain of the SCIDAR CCD; and exposure of the acquisition camera.

User interface

The graphical user interface (GUI, see Figure 4) displays the following data to the user via the terminal of the supervisor PC:

- images from the acquisition camera (Figure 5);
- images from the two SCIDAR pupil (science) cameras (Figure 5);
- the turbulence profile through the night;
- some data on the current target and atmospheric conditions (target identifi-

Figure 4. The Stereo-SCIDAR control GUI.

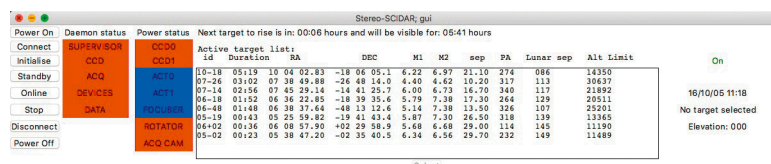

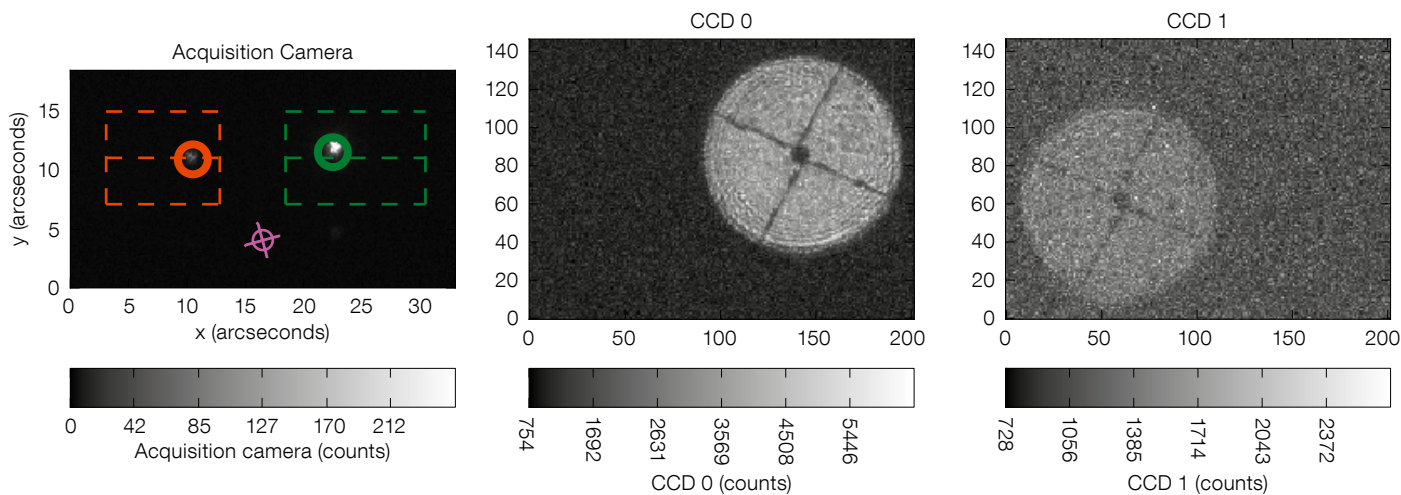

Figure 5. Examples of Stereo-SCIDAR camera images. The acquisition camera is on the left. The rotation should be such that the green circle (indicating the brighter star) is on the green (right hand side) of the frame. This is to ensure that the system knows the orientation on the sky. Each of the two pupil images are shown in the centre and right panels.

cation, time until it sets, time at which it sets, and the current atmospheric parameters — Fried parameter (r_0), θ_0 , τ_0 and the scintillation index).

Data reduction

The data reduction pipeline runs on the supervisor PC. It processes the images from the science cameras in real time to yield the optical turbulence strength and wind velocity profiles, as well as derived atmospheric parameters such as θ_0 and τ_0 . The data reduction pipeline is identical to that used by existing Stereo-SCIDAR instruments and details can be found elsewhere (Shepherd et al., 2014).

Commissioning results

Having been successfully integrated at the coudé focus of the VLT AT, Stereo-SCIDAR achieved first light in April 2016, delivering its first turbulence profile of the atmosphere above the Paranal Observatory. A second campaign of five nights was conducted in July 2016. The commissioning team (Figure 6) had the opportunity to operate Stereo-SCIDAR for a total of 11 nights in order to test functions, interfaces, operation and data archive of

the instrument, confirming the readiness of Stereo-SCIDAR for the one-year test campaign starting in October 2016.

All the functions and performance of Stereo-SCIDAR were tested, and demonstrated full compliance with the requirements. During the commissioning nights the GUI was optimised, taking into account the remarks and requests of the TIOs.

Profiles were recorded each night when the weather allowed. We did not identify any major problems with the AT interface and operation, or with the instrument that resulted in any downtime. Atmospheric profiles (Figure 7) recorded during the first commissioning phase demonstrated the reliability of the data reduction software.

First profiles

A screen shot from the commissioning run on 29 April 2016 is shown in Figure 7. The many short vertical breaks seen in the lower panel on Figure 7 are pauses for field de-rotation to correct for the sky rotation, due to the altitude-azimuth telescope; the longer breaks (approximately 5 minutes) are for target changes. As can be seen from the lower panel on Figure 7, some turbulent layers appear stable and are visible for almost the whole night, for example at ground level and at 2.5 kilometres. Other layers are more transient, with layer strengths and altitudes varying over the course of minutes.

Figure 6. The Stereo-SCIDAR commissioning team at Paranal.

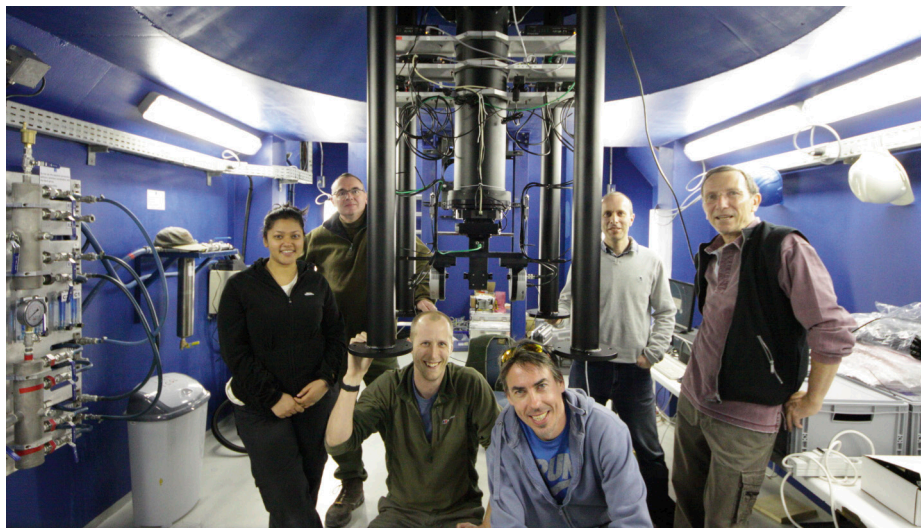

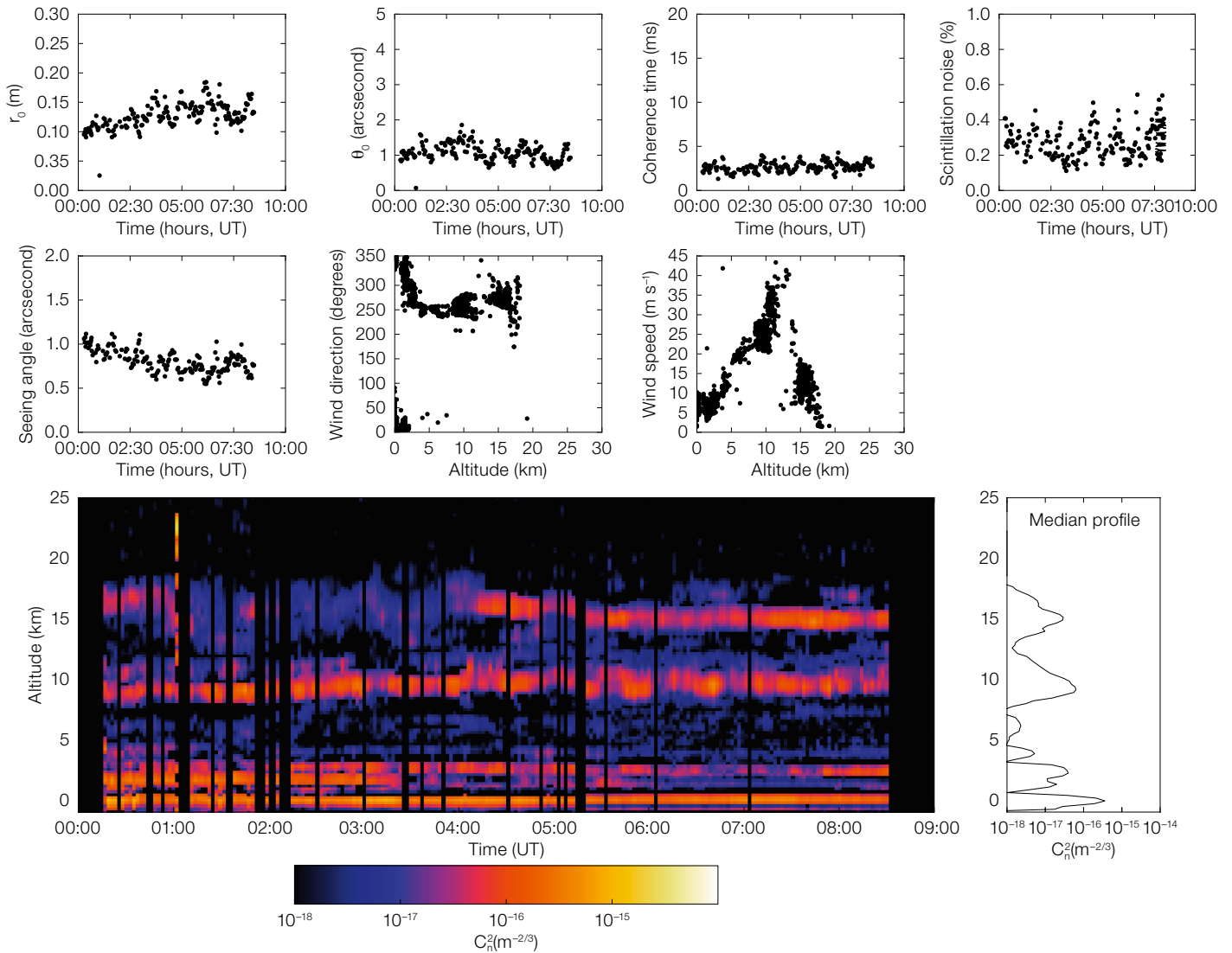

Figure 7. Stereo-SCIDAR real-time display, showing commissioning data from the night beginning 29 April 2016. The top two rows of panels show the evolution of the integrated atmospheric parameters throughout the night as well as the turbulence speed and direction profile. The lower panel shows the evolution of the turbulence altitude distribution, with altitude shown vertically and time running horizontally. The colour indicates the strength of the turbulence, and the upper magenta line marks the maximum profile altitude. The lower right hand plot shows the time-integrated C_n^2 value with altitude.

Wind velocity identification

In order to validate the wind velocity identification, we compared wind and turbulence velocity profiles from the Stereo SCIDAR instrument (via its automated wind velocity detection algorithm) with wind data from the European Centre for Medium-Range Weather Forecasts, (ECMWF) numerical forecast for Paranal. Figure 8 shows the comparison of identified layers for these data sources. The correlation is high for both turbulence speed and velocity, confirming the validity of the Stereo-SCIDAR automated wind velocity identification algorithm.

Conclusions

Stereo-SCIDAR, a high resolution atmospheric turbulence profiler, has been commissioned on one of the 1.8-metre ATs at Paranal, situated only 22 kilometres from the site of the future ELT. The data from Stereo-SCIDAR are critical for design studies of ELT instrumentation as well as performance monitoring and optimisation of existing VLT and future ELT operations. Stereo-SCIDAR will operate at Paranal for several nights per month for at least one year.

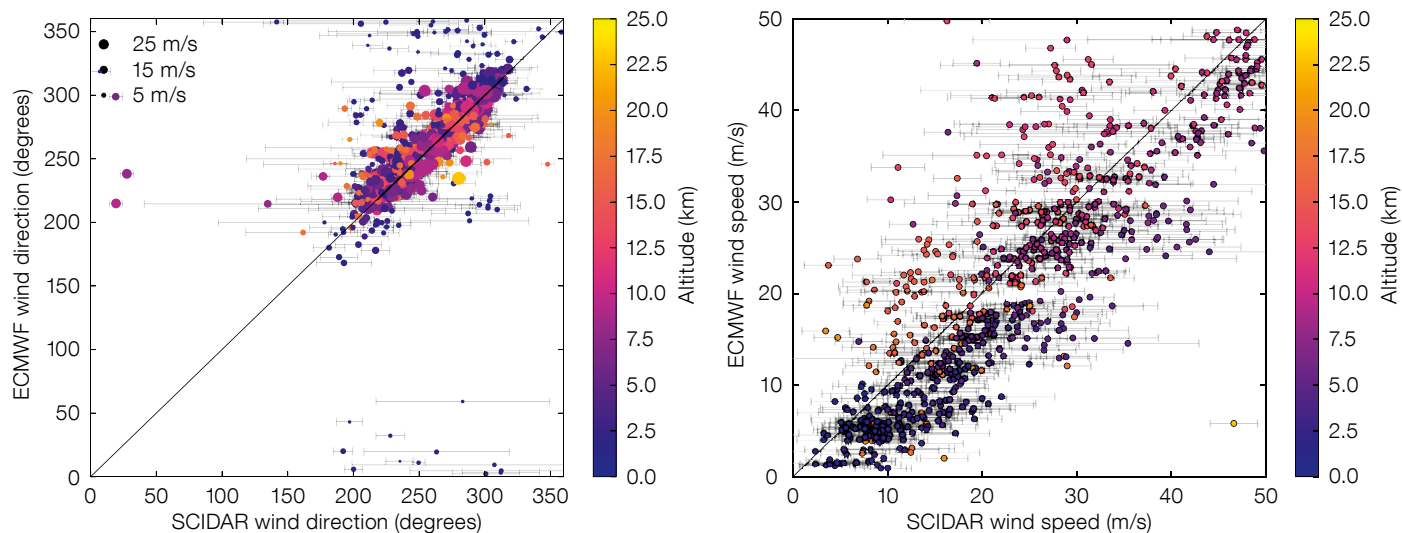

Figure 8. Comparison of SCIDAR and ECMWF wind velocities (direction, left, and speed, right) for the commissioning data. The colour denotes the altitude of the identified turbulent layer. For the wind direction (left) the size of the data point denotes the wind speed.

References

Shepherd, H. W. et al. 2014, MNRAS, 437, 3568
 Vásquez Ramió, H. et al. 2008, The Messenger, 132, 29



G. Avila/ESO

High altitude cirrus cloud can give rise to a circumhorizontal arc from refraction by ice crystals, here photographed at Paranal above the Astronomical Site Monitor.