

The 3.6-m Dome: 30 Years After

Gerardo Ihle, Nelson Montano,
Roberto Tamai (all ESO)

After rotating for more than 30 years, the dome support wheels for the ESO 3.6-m telescope started to degrade, resulting in a shutdown in October 2006. The engineering process of reshaping the track and gradual replacement of the supporting wheels is described. The rotation of the dome is now returning to its original efficiency.

It is more than 30 years since the 3.6-m telescope (Figure 1) saw first light and the dome started to turn. Through all these years this telescope has been a flagship of La Silla and a continuous source of scientific return. The heavy structure, based on 'classical' telescope and dome construction, has continued to operate with minimum interruption due to significant failures.

The rotating part of the dome is a steel structure, built by Krupp, with an estimated weight of 350 tons. Thirty wheels support the dome as it turns on a rail fixed on top of the concrete part of the building. The movement is controlled by two sets of friction wheels that allow the dome to move during pre-setting and tracking, or simply positioning.

But after all these years the dome rotating part began to feel the test of time. Seven years ago the failures of the supporting wheels occurred, requiring the change of these units.

In 1999 we started the search for a provider who could help in the repair of the damaged wheels, but without success. The company that made these wheels for Krupp had disappeared. We could not find any European provider who, taking into account the Europe-La Silla time and space separation, was willing to produce the right rubber component for us, within reasonable costs.

The supporting wheels are built with a central mass used to house the bearings and the axis that fixes the wheel to the support unit or bogie (see Figure 2). A cast rim is used as the rail rolling contact surface and between these two metal-



Figure 1: The 3.6-m dome at La Silla pictured during unusual weather.



Figure 2: One of the original dome bogies, with the large centred wheel and rubber rim, is shown.

lic parts a compound rubber vulcanised layer joins them, providing the elastic part of the structure (see the sketch in Figure 3). Two lateral wheels centre the dome while it is turning (white in Figure 2).

The quest of finding the right rubber for replacement was not easy as the information was no longer available from the as-built configuration and the characteristics of the rubber were difficult to obtain from a degraded compound. Only after extensive investigation did we reach a company from the Weir Minerals group, called VULCO, that produces spare parts or special products for mines in Chile. They were willing to find the right compound, but this proved not to be an easy task. Many wheels were tried, a lot of

water flowed under the bridge, but the problem still remained.

A serious problem triggered the shutdown at the beginning of October 2006, when a chain reaction of failures rendered the dome impossible to move. Interventions to overcome the problem proved unsuccessful; the solution required a decision to stop the dome for a long period.

The wheel rims had completely lost their shape (in terms of angle, concentricity with the axis, deformation of the rolling surface, etc.), but so also had the rail lost its top flat surface. The rails had built up an inverted V shape section (see sketch in Figure 4, right). In addition the rail was

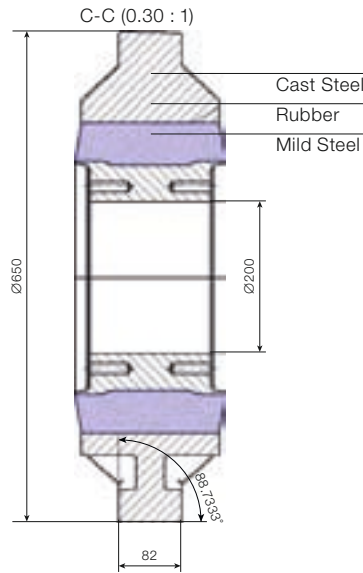

Figure 3: Details of the composite structure of the dome support wheels.

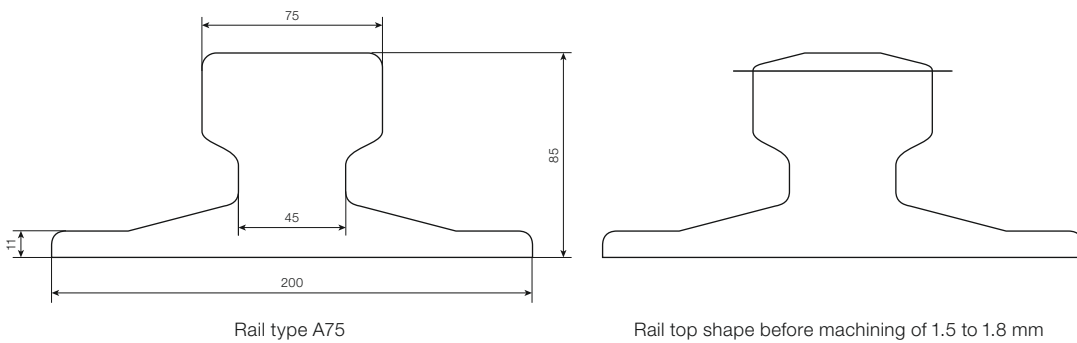
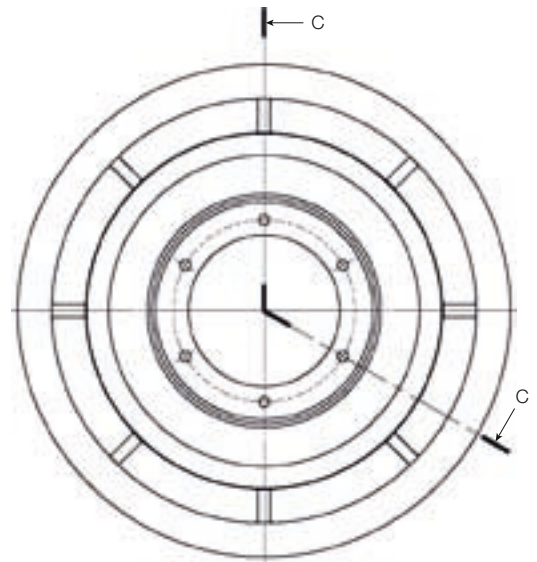

Figure 4: Shown left is the original profile of the support rail, and, right, the rail profile after 30 years of use. The rail top was machined 1.5 to 1.8 mm to restore the profile (shown by the line in the right figure).

not flat on a plane but showed hills and valleys around its perimeter.

The condition of the wheels and the rail resulted in unacceptable force during rolling of the wheels, creating excessive stresses in the rubber and rail system. The failure rate thus began to increase.

These conclusions were reached after a survey campaign of the rail and wheels, conducted with the cooperation of Maintenance and Engineering Departments of the La Silla Paranal Observatory. The close collaboration made possible a rescue plan to correct these problems.

First we had to make extensive measurements of the situation with a theodolite,

then conduct a study of the situation of the rail with respect to the enclosure shape and relative dome positioning. Then the re-machining of the outer rim of the wheels to the right shape was done, together with the milling of the top surface of the rail (Figure 4, right) with the help of a specially designed milling head (shown in Figure 5) attached to the rotating part of the dome itself. The centring of the dome was performed by adjusting the two lateral wheels of each bogie. When this was not possible the bogies were re-positioned in order to have the wheels centred on top of the rail. All these activities took place in October 2006, and gave the first results by delivering the dome and telescope back to the community on 4 November.

After the unsuccessful attempts to find the proper rubber compound for the wheels, a more radical solution to the dome wheel problem was considered: the design and fabrication of entirely new wheel units. Figure 6 shows a cut-away design of one of the new wheel units. The construction is based on a double-wheel carriage supported by friction springs and with the possibility to measure, via load cells, the load applied in the respective bogie. This is an advantage with respect to the original design because it allows a constant control of the load along the rail track.

The new wheels have so far been installed in eight positions out of 30, and Figure 7 shows one of the installed

units. The loading has been recorded along the rail track and these wheels have helped to relax the loading on the other wheels and thus improve the load distribution of the dome onto the supporting rubber wheels.

After a long period working in a slow velocity mode, and after 109 rubber wheel replacements, the dome rotation returned to the nominal full rotational speed resulting in optimal utilisation of the observing night. It was concluded that a rubber compound with a Shore A hardness of 65 to 70 and a breaking modulus of 23–25 MPa was the most appropriate for these wheels and for their expected loading. At the end of this set of repairs, the dome is returning to the efficiency that the designers and constructors envisaged, and science on the 3.6-m telescope is benefitting.

Acknowledgements

The Maintenance and Engineering Departments of La Silla and Paranal made possible the return of the telescope to normal use with the minimum of effect on observations. The group of engineers and technicians of both sites in La Silla Paranal Observatory brought this project to a happy end.



Figure 5: The special milling head, fabricated to machine the rail, attached to the dome.

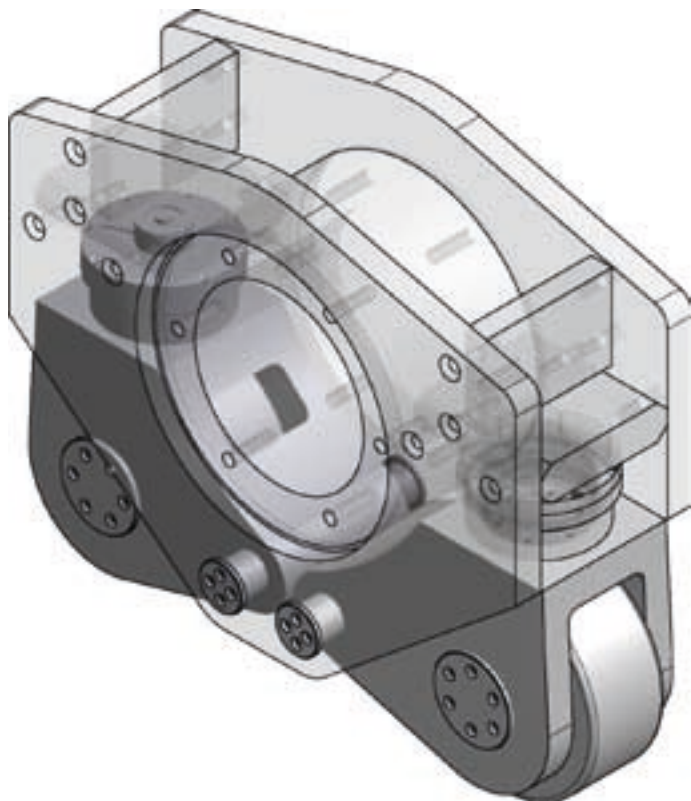

Figure 7: One of the eight new wheel units is shown in position attached to the dome.

Figure 6: A cutaway showing the design of one of the new dome support wheel units.