

Adaptive Optics Facility – control strategy and first on-sky results of the acquisition sequence

P-Y Madec¹, J. Kolb, S. Oberti, J. Paufigue, P. La Penna, W. Hackenberg, H. Kuntschner, J. Argomedo, M. Kiekebusch, R. Donaldson, M. Suarez, R. Arsenault

European Southern Observatory, Karl Schwarzschild Str 2, D-85748 Garching

ABSTRACT

The Adaptive Optics Facility is an ESO project aiming at converting Yepun, one of the four 8m telescopes in Paranal, into an adaptive telescope. This is done by replacing the current conventional secondary mirror of Yepun by a Deformable Secondary Mirror (DSM) and attaching four Laser Guide Star (LGS) Units to its centerpiece. In the meantime, two Adaptive Optics (AO) modules have been developed incorporating each four LGS WaveFront Sensors (WFS) and one tip-tilt sensor used to control the DSM at 1 kHz frame rate. The four LGS Units and one AO module (GRAAL) have already been assembled on Yepun.

Besides the technological challenge itself, one critical area of AOF is the AO control strategy and its link with the telescope control, including Active Optics used to shape M1. Another challenge is the request to minimize the overhead due to AOF during the acquisition phase of the observation.

This paper presents the control strategy of the AOF. The current control of the telescope is first recalled, and then the way the AO control makes the link with the Active Optics is detailed. Lab results are used to illustrate the expected performance. Finally, the overall AOF acquisition sequence is presented as well as first results obtained on sky with GRAAL.

Keywords: adaptive optics, active optics, ground layer adaptive optics, laser tomography adaptive optics, laser guide star, deformable secondary mirror, adaptive optics control

1. INTRODUCTION

The Adaptive Optics Facility (AOF) project ([1] and [2]) is supervising the development and delivery to Paranal Observatory of four main sub-systems: a Deformable Secondary Mirror (DSM), a 4 Laser Guide Star Facility (4LGSF) and two post-focal wavefront sensor (WFS) modules. During the last two years, the project has been leading its sub-systems into many acceptance reviews in Europe, and the center of gravity of the AOF is now shifting to Paranal.

During 2015 the first Laser Guide Star Unit (LGSU#1) of the 4LGSF has been installed and commissioned in Paranal, showing fantastic performances. Starting from January 2016, the three remaining LGSU's were re-integrated in Paranal and installed on Yepun. On April 26th the 4LGSF first light took place; commissioning happened in May and June and has demonstrated the efficiency and the robustness of the system.

In the meantime, a two years long system tests phase has just been concluded in Garching (February 2016). The AO modules GRAAL and GALACSI were in this order, mounted on the ASSIST test bench and tested in realistic conditions. GRAAL is the WFS module associated to HAWK-I, a wide field IR imager in operation in Paranal. GRAAL tests were completed in early 2015. Following a successful acceptance in Europe, GRAAL has been shipped and re-integrated in Paranal in June 2015. This provided a unique opportunity in October 2015 to have a combined commissioning run with the LGSU#1 and GRAAL allowing to debug and test many aspects of the acquisition sequence of the AOF on the telescope in real conditions.

In the following sections, the actual development status of the project is recalled, in support to the description of the control strategy of AOF and its acquisition sequence. Section 2 describes the status of the AOF sub-systems. Section 3 details and explains the AOF control strategy, focusing mostly on interactions with the telescope active optics. Finally, section 4 introduces the AOF acquisition sequence and gives first on-sky results obtained with GRAAL coupled to LGSU#1.

¹ pmadec@eso.org; phone +498932006660

2. AOF DEVELOPMENT STATUS

2.1 4LGSF highlights

During 2015 the 4LGSF was leading in parallel the installation and commissioning of the first Laser Guide Star Unit (LGSU#1) and the validation of the 3 other units in Garching, concluded by the 4LGSF acceptance in Europe at the end of 2015. The LGSU#1 commissioning was completed in August 2015 and showed fantastic performances. It confirmed the good design choices and validated all interfaces with Yepun. In January 2016, the three remaining LGSU's were re-integrated in Paranal and installed on the telescope. On April 26th, 2016 the 4LGSF first light took place (see Figure 1) and the commissioning of the 4LGSF in stand-alone mode started. All performance have been demonstrated to be in specifications [3], the most important ones being:

- high power output; 20 Watt
- blind pointing accuracy of the laser spot; < 5'' PV
- spot size; <1.35'' for a 1'' seeing (30° from zenith)
- return flux; > 7.7 10⁶ photons-m⁻²-sec⁻¹ (for average Na density 4x10¹³ m⁻²)
- reliability and robustness



Figure 1 - Left: the four LGS Units mounted on the Yepun centerpiece with their respective laser and instrument control cabinets. Right: a view of a launch of the four lasers.

2.2 GRAAL-LGSU#1 Combined Tests

The GRAAL module [4] is serving the Hawk-I imager and provides a Ground Layer Adaptive Optics (GLAO) correction in the 7.5 arcmin field of view of Hawk-I. It also offers a mode called Maintenance and Commissioning Mode (MCM)

featuring on-axis natural guide star adaptive optics. This mode allows to fully exploit the DSM 1170 degrees of liberty and aims at testing and validating the correction capability of the mirror.

GRAAL is making use of 4 LGS WFS and one visible Tip-Tilt Sensor (TTS). In its GLAO mode, the measurements coming from the 4 LGS WFS are multiplied by individual control matrices, and the final delta-commands are averaged. Then a pure integrator is applied, and the final commands are sent to the DSM. Tip-tilt corrections are computed from the TTS measurements, while the tip-tilt measured by the LGS WFSs is sent to the jitter mirrors located within the LGSUs optical train.

The installation of GRAAL on UT4 took place in June 2015 and the combined commissioning with LGSU#1 in October 2015. Obviously, no adaptive optics verification could be done in October 2015 without the DSM. However, many loops and offloads scheme could be tested and the LGSU#1 could be acquired on one LGS WFS and the Tip-tilt star selection tested. This allowed many steps to be exercised in real conditions and offered reassurance as to the estimated acquisition overhead already tested on ASSIST in Garching. All the loops have been closed (except the main adaptive optics loop with the DSM), including the Jitter loop allowing to verify the interfaces between GRAAL and the 4LGSF. First results obtained on-sky were extremely positive [5].

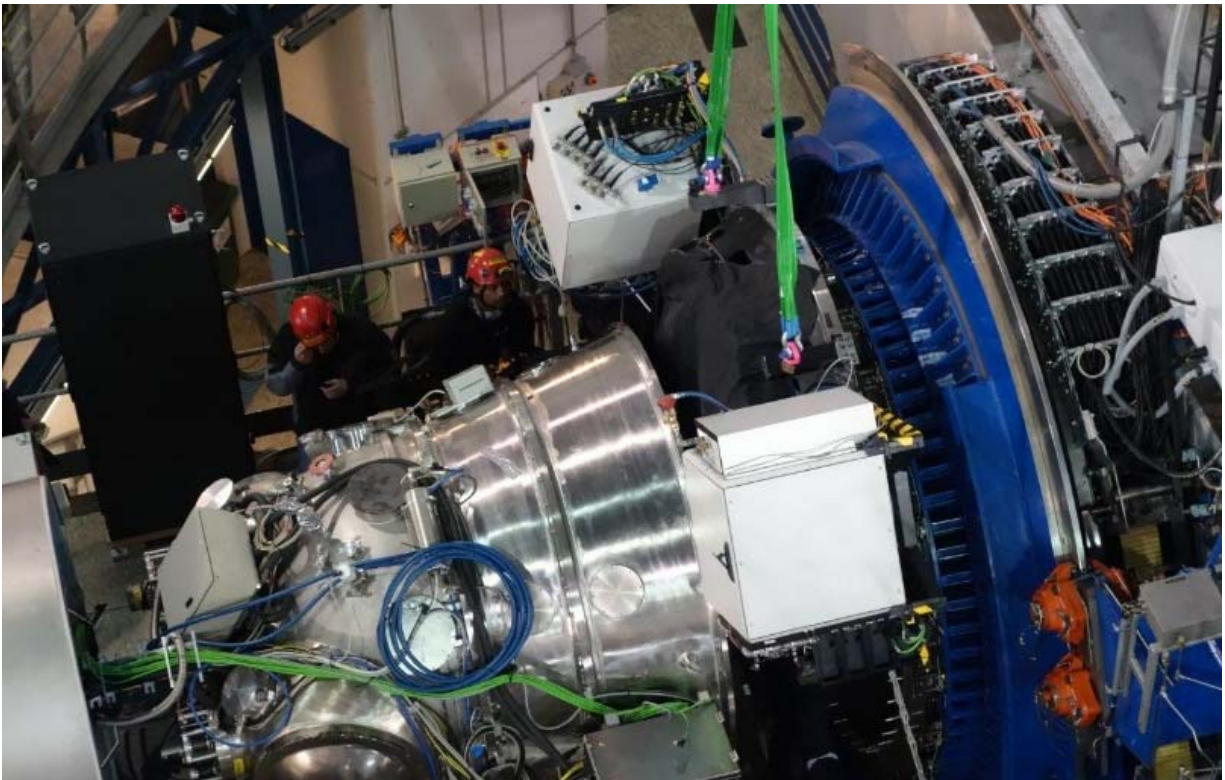

Figure 2: The GRAAL module being handled above the Nasmyth A platform of UT4 to be inserted in sandwich between Hawk-I and the Nasmyth flange (“inside” the Hawk-I housing).

2.3 GALACSI performance in the lab

The GALACSI module is serving MUSE, a visible 3D spectrograph [6]. MUSE is featuring two modes: a Wide Field Mode (WFM) with a 1×1 arcmin² field of view, and a Narrow Field Mode (NFM) with 7.5×7.5 arcsec² field of view. In WFM, GALACSI delivers a GLAO correction within the MUSE field of view, while in NFM GALACSI has to provide MUSE with diffraction limited images thanks to Laser Tomography Adaptive Optics (LTAO).

In its WFM, GALACSI is making use of 4 LGSs located at 1 arcmin from the telescope optical axis and one visible Tip-Tilt star [7]. Sensor measurements are processed in the same way as GRAAL to deliver commands to the DSM. LGS jitter is stabilized thanks to jitter mirrors located within the LGSWFS path of GALACSI.

In its NFM, GALACSI is also using 4 LGSs but located much closer to the telescope axis (10 arcsec). The IR light of the science object is used to feed an IR Low Order Sensor (IRLOS) delivering tip-tilt and focus measurements. The measurements coming from the 4 LGS WFS are combined through a tomographic algorithm to reconstruct the turbulent volume above the telescope. Atmospheric aberrations are then projected on the DSM looking towards the center of the telescope field of view.

During 2015, GALACSI has been tested in the lab together with the DSM, thanks to the use of ASSIST, the AOF test facility [12] (see Figure 3). WFM tests were carried out relatively fast as they implemented similar algorithm to the GRAAL GLAO correction ([8] and [9]). Little surprise was expected. However, the GALACSI NFM was a different story as it involved a new, complex algorithm of LTAO. The complete definition of the command matrix for this algorithm was defined by the ESO adaptive optics group and performed beyond our expectations [10].

The system tests of GALACSI have been completed end of February 2016. The shipment of GALACSI will happen end of 2016 as soon as the new M2 Unit is installed on the telescope. Then GALACSI will be assembled on the telescope and the final commissioning will start by April 2017.

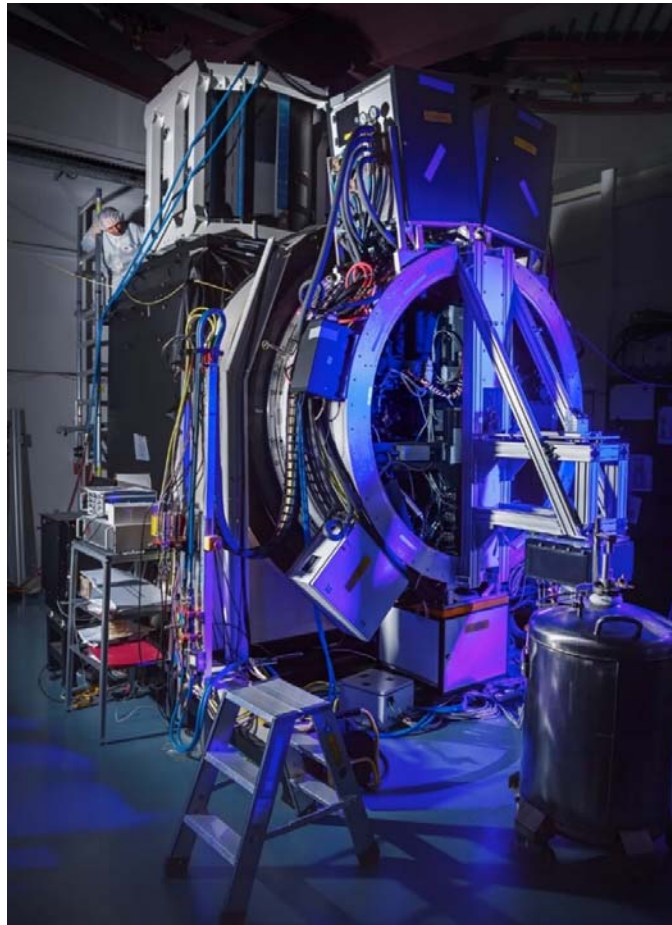

Figure 3 - The GALACSI module mounted on ASSIST test bench. A special rig has been produced to interface IRLOS to GALACSI

2.4 DSM: on its way to the mountain

The AOF DSM is featuring an optical shell 1.1 m diameter and 2 mm thin, “floating” on a magnetic field created by 1170 voice coil actuators. Typical settling time of DSM actuators has been measured to be less than 0.7 ms, while the ultimate surface quality of the shell can be as good as 10 nm rms [11].

Following the completion of the GALACSI system tests (see previous section), the DSM has been removed from the top of ASSIST to be serviced before being shipped to Paranal. A second shell, used as a spare, has been assembled on the DSM and will be optically calibrated during July 2016. Once the optical flat commands are defined, the DSM 1 will be packed and shipped to Paranal. It is planned to have the new M2 Unit assembled on Yepun during October. Then the telescope as well as the full suite of instruments, including the VLTI, will have to be re-commissioned.



Figure 4 – front view of the DSM, with the optical thin shell installed

3. AOF CONTROL STRATEGY

In the following sections, the AOF control strategy is described, focusing mainly on interactions with the active control of the telescope. In section 3.1, the control of the telescope is presented when AOF is not used. Section 3.2 then details how AOF control is interfacing with the telescope active optics.

3.1 Telescope control in non-AO mode

When in non-AO mode, the DSM optical shape is set to its best “flat”, with a surface figure standard deviation as small as 10 nm rms compared to the theoretical optical prescription of the telescope. Additionally, an hexapod is used to control the rigid-body motion of the DSM in the telescope coordinate system, by adjusting the longitudinal position of its vertex along the telescope optical axis (focus control) and its lateral position (pupil lateral motion).

The telescope active optics control is described in Figure 5.

To start a new observation, the position on-sky of the object of interest is sent to the telescope axes. The telescope is moving to this pre-defined position and when on-target, is set in tracking mode: it follows the theoretical trajectory of the object, being it sidereal or non-sidereal. Pointing and tracking accuracy rely on the reading of the encoder axes and on a calibrated pointing model. As soon as tracking is set, the telescope primary mirror (M1) is shaped to a pre-calibrated optical figure accounting for telescope altitude and environmental parameters as temperature for example.

To improve the pointing accuracy and the optical quality of the telescope, a reference guide star is selected outside the scientific field of view of the instrument and propagated to a sensor arm. Each telescope focus contains its own sensor arm; this is the most important component of the telescope, in charge of the final pointing accuracy and optical quality delivered to the instruments. Each sensor arm contains one guide probe and one active optics Shack-Hartman (SH) WFS.

The guide probe measures in real time the position of the guide star and sends tip-tilt correction commands to the secondary mirror at a maximum frequency of 100 Hz (typical control frequency is 50 Hz). This is the so-called field-stabilization. Long term average of the commands is offloaded to the telescope axes.

In parallel, the active optics SH WFS takes a long exposure measurement of the optical aberrations of the telescope. Exposure time depends on the guide star brightness and is typically equal to 1 minute. It allows to get a good signal-to-noise ratio, and to average-out the contribution of the turbulence. WFS measurements are projected on the 29 first elastic modes of M1 (active optics control basis - piston and tip-tilt are excluded from this control basis). Focus and coma are sent to the M2 hexapod (control of longitudinal and lateral position of M2), while the remaining 26 modes are sent to M1. Field stabilization and active optics are running in parallel during the observation.

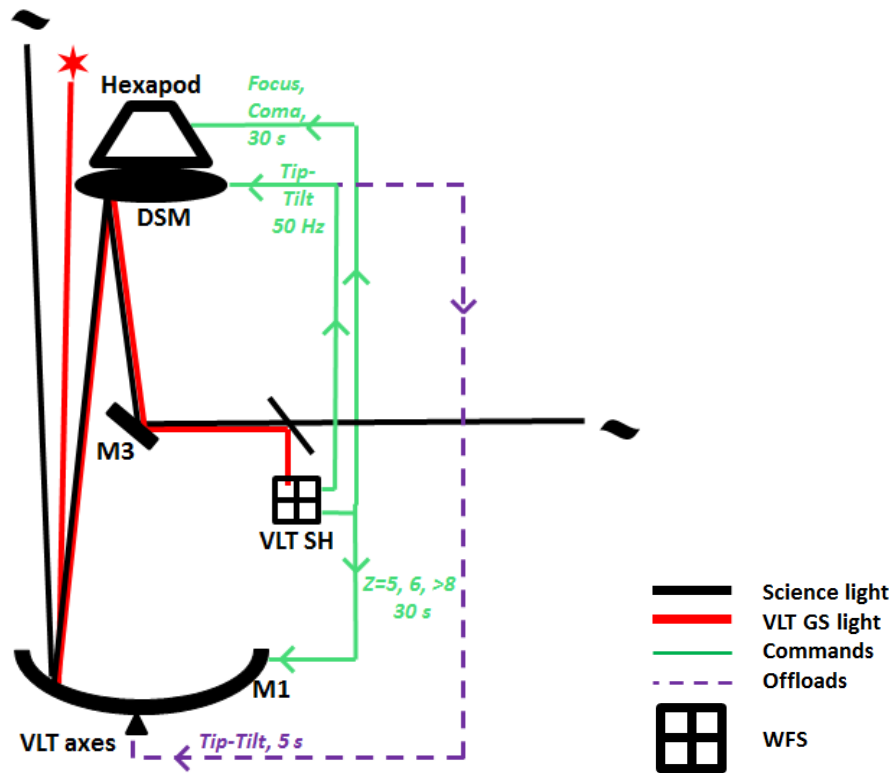

Figure 5 – Active optics control of the telescope in non-AO mode

3.2 Interaction between the telescope active optics and the AOF control

The description of the AOF control and its interaction with the telescope active optics is presented in Figure 6, where GALACSI WFM is taken as an example.

AOF is making use of the following sensors:

- Four LGS SH WFS, sampling the pupil with 40x40 sub-apertures. Control frequency is 1 kHz.
- One Natural Guide Star (NGS) visible tip-tilt sensor, with a control frequency of 200 Hz.

These sensors are used to control AOF “actuators”:

- The 1170 voice coil actuators of the DSM.
- Four LGS jitter mirrors, with two axes per mirror. These mirrors are used to stabilize the image of the LGS in front of each LGS SH WFS. There is one jitter mirror per LGS WS.
- Four LGS Field Steering Mirrors (FSM), with two axes per mirror. These mirrors are used to position each LGS at their nominal position with respect to the telescope optical axis. They feature a large stroke but a slow response time (0.2 s per on-sky arcsec). There is one FSM per Laser Guide Star Unit.
- One focus compensator, used to adjust the focalization of the LGS WFSs to the actual Sodium layer distance. There is only one focus compensator, shared by the four LGS WSs.

When operated in close loop, measurements coming from the four LGS WFS are multiplied by a control matrix to deliver four vectors of delta commands. These four vectors are averaged (Ground Layer AO control algorithm), and the final delta commands are used to elaborate the High Order (HO) commands of the DSM by applying a pure integrator. Tip-tilt commands are filtered out from each control matrix. In parallel, the tip-tilt sensor measurements are used to compute tip-tilt commands through again a pure integrator. These tip-tilts commands are converted into the DSM zonal control space thanks to a 2×1170 matrix multiplication. Tip-tilt and HO commands are summed-up before being applied to the DSM actuators.

Safety checks and saturation management are performed by the DSM control electronics. In case of any problem, the control vector is simply rejected (the DSM shape is frozen) and the AOF Real Time Computer is notified of this rejection. Tip-tilt measurements coming from the LGS WFS are used to control the jitter mirrors: stabilization of the LGS image into the WFS sub-apertures allows to improve the WFS linearity. Jitter commands are offloaded at 1Hz onto the LGS FSM.

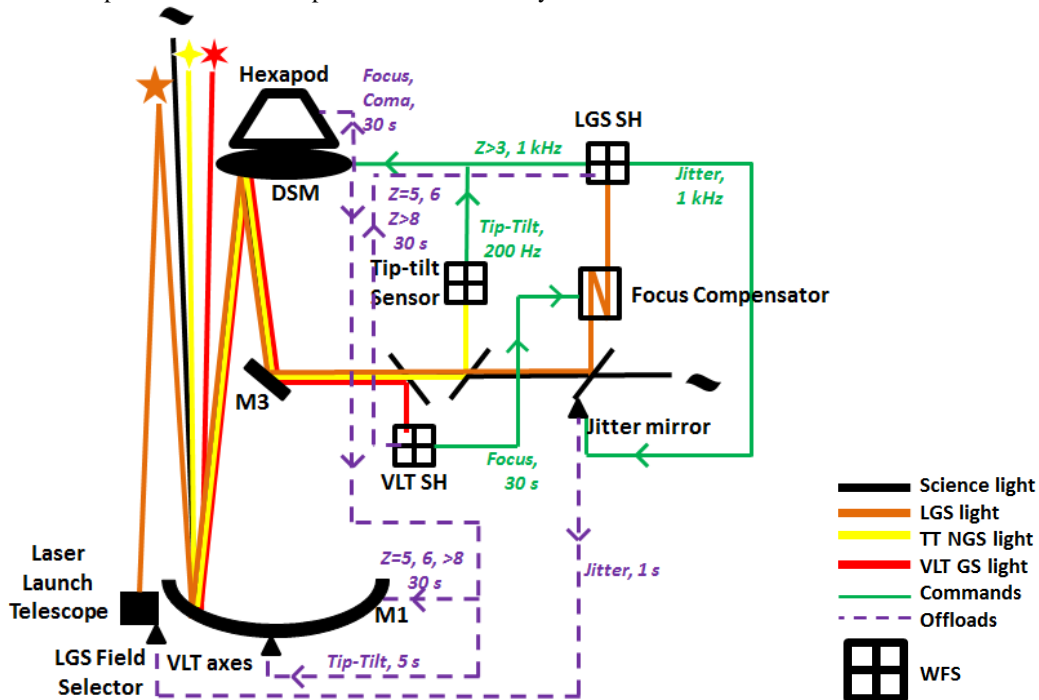

Figure 6 – AOF control and interaction with the telescope active optics

When AOF is operated in real-time closed-loop, the DSM is compensating all optical aberrations measured by the LGS WFSs and tip-tilt sensor. The DSM being located upstream the telescope sensor arm and being controlled at 1 kHz, both guide probe and active optics WFS only see residual aberrations: the active optics is becoming blind. To avoid the DSM being saturated by the correction of the large aberrations coming from M1, HO commands are time-averaged and projected onto the 29 first elastic modes of M1. Long term focus and coma are sent to the hexapod while the other modes are used to control the shape of M1. In parallel, the DSM tip-tilt is offloaded to the telescope axis. Following this strategy, the telescope is controlled in exactly the same way it is controlled without AOF; the DSM plays the role of the telescope sensor arm.

Additionally, the active optics SH WFS is used as a truth sensor: focus measurements coming from this sensor are used to offset the position of the LGS focus compensator, while higher order modes contribution (if any) is used to offset the LGS WFS reference slopes.

Following this overall control strategy, the lateral position of the DSM is defined to minimize the decentering coma. This means that mis-registration between the DSM and the LGS WFS will be experienced. This is managed by updating on-the-fly the control matrix: every 5 to 10 minutes: the mis-registration is evaluated from real-time AO telemetry data [13] and used to update the Pseudo-Synthetic Interaction Matrix (PSIM) and then derive a new control matrix.

This global control strategy and interactions between adaptive and active optics maximizes the chance to get the best performance from the complete system.

4. AOF ACQUISITION SEQUENCE

4.1 Acquisition sequence description

Amongst all AOF requirements, the toughest one is certainly the acquisition overhead: AOF is not allowed to add more than 5 minutes (goal 2 minutes) to the non-AO acquisition time. To meet this requirement, it is mandatory:

- To run the complete acquisition sequence in a fully automatic mode, with as less human intervention as possible.
- To parallelize most of the steps of the acquisition sequence.
- To make use of the time required to preset and bootstrap the telescope to perform most of the steps required by AOF.

The different steps of the AOF acquisition sequence are presented in Figure 7.

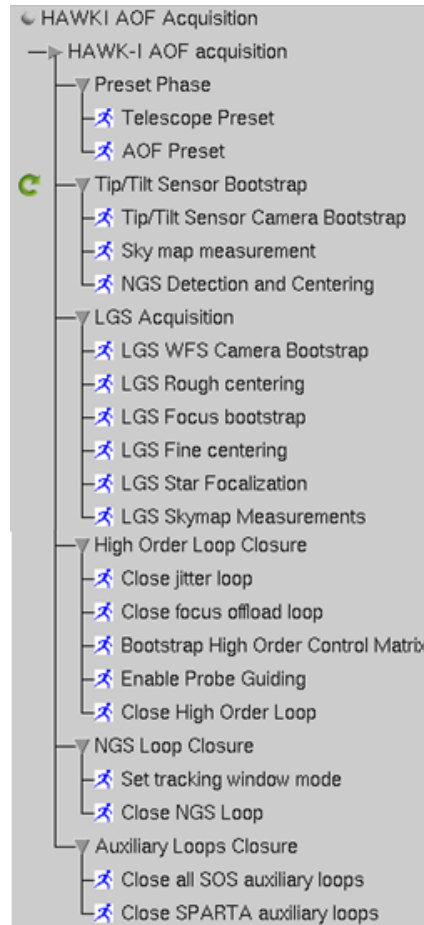

Figure 7 – Screen shot of the Observation Blocks defining a typical AOF acquisition sequence

The AOF acquisition sequence starts by the preset phase during which first the telescope is preset as described in section 3.1 and then, as soon as the slewing is completed and the tracking enabled, the AOF is preset. AOF preset mainly consists in presetting the 4LGSF: the four LGSU FSM are preset to their nominal position, the 4 lasers are then propagated and the Laser Pointing Camera used to measure accurately and to finally adjust the position of the four LGSs with respect to the telescope optical axis. Presetting the four LGSUs is done in parallel to save precious time.

As soon as the telescope is guiding, and without waiting for the completion of the 4LGSF preset, the tip-tilt sensor is bootstrapped. This step consists in setting the tip-tilt sensor camera gain to its nominal value (100 to get a read-out-noise smaller than 1 e⁻/pixel/frame), and then detecting the tip-tilt star within the search window of the sensor. Detection of the

star is done automatically by the AOF software, but the telescope operator has to acknowledge manually that the star is suitable. Once the tip-tilt star is identified, it is automatically centered within the central 32x32 pixels defining the tracking window of the sensor.

Following the completion of both the 4LGSF preset and the tip-tilt sensor bootstrap, the LGS acquisition can start.

- The first step is to set the gain of the four LGS WFS cameras to their nominal value (gain 100).
- The four lasers are then propagated and detuned to record the background in all four LGS WFS.
- The lasers are retuned, and the AOF SW detects automatically if the LGS are within the 5 arcsec field of view of the LGS WFS. The detection is based on the measurement of the intensity within the LGS WFS sub-apertures.
- In case one LGS is not within the LGS WFS field of view, a spiral search is started automatically. The detection criteria is again the intensity in the LGS WFS sub-apertures.
- Once all LGS are detected, they are all automatically centered by controlling the FSMs of the LGSUs and focused by adjusting the position of the focus compensator.

Again, the detection and centering of the four LGSs is done in parallel.

Once all LGSs are acquired, the next step consists in closing the high order loops, starting first with the jitter loops and then the high order loop itself. Then the tip-tilt loop is closed as well as all auxiliary loops: DSM offload loops towards the active optics control, DSM/WFS mis-registration and control matrix update, LGS spot size measurement and update of WFS weighting maps (required to implement the weighted center of gravity algorithm).

4.2 First on-sky timing of the acquisition sequence

The complete acquisition sequence has been developed and debugged during the AOF system tests on ASSIST. Obviously, it has not been possible to verify the interfaces with the 4LGSF nor the telescope during these tests, but most of the critical phases have been exercised. A first timing has been performed in these conditions and first results have been found to be in the range of 2 to 4 minutes depending if the four LGSs were or were not within the LGS WFS field of view. This timing corresponds to the complete AOF acquisition sequence, without accounting for the telescope preset.

In November 2015, GRAAL and the LGSU#1 were both available on Yepun in Paranal. It has been possible to use one of the four LGS WFSs of GRAAL to acquire the LGS#1 and go then through very interesting tests, amongst which:

- Recording of the first jitter loop interaction matrix and FSM offload sensitivity matrix.
- Closure of the jitter loop and FSM offload loop; measurement of the associated rejection transfer functions.
- Verification on-sky of the LGS WFS and tip-tilt sensor plate scale.
- Measurement of the pupil/WFS registration stability as a function of the telescope elevation.
- Measurement of the LGS return flux and spot size as seen by the GRAAL WFS.
- And last but not least, on-sky debug and timing of the AOF acquisition sequence.

Test results are presented in [5].

During the last night, ten successive acquisition sequences have been run on ten different targets, located at different altitudes on the sky. Amongst these ten tests:

- Six AOF acquisition sequences have been completed before the end of the second telescope active optics loop, which defines usually when observation can start.
- Four AOF acquisition sequences took an additional 2 to 4 minutes to complete following the end of the second telescope active optics loop. This happened when LGS#1 was not within the LGS WFS field of view, requiring to go through the spiral search.

These very first results are extremely encouraging. All acquisition sequences have been completed successfully, and within the 5 minutes allocated to AOF. Further improvements of the acquisition sequence have been identified and will be implemented soon, as well as improvement of the 4LGSF preset.

AOF project is now looking forward installing the DSM and GALACSI on Yepun (respectively by the end of 2016 and in March 2017), and going through the complete commissioning of this challenging facility. MUSE and GALACSI in their WFM configuration should be offered to the community by October 2017.

5. ACKNOWLEDGEMENTS

I am very grateful to all my colleagues at ESO involved in the AOF project for so many years, and more particularly to: E. Vernet, J.-F. Pirard, M. Le Louarn, S. Stroebale, D. Bonaccini Calia, T. Pfrommer, R. Holzloehner, S. Lewis, J.L. Alvarez, R. Conzelmann, R. Guzman Collazos, M. Quattri, P. Jolley, R. Ridings, J.A. Abad, C. Frank, J. Quentin, B. Delabre, S. Guisard, L. Pettazzi, S. Babak, F. Gago, A. Jost, I. Guidolin, L. Kern, G. Fischer, A. Haimerl, C. Soenke, M.

Downing, J. Reyes, L. Mehrgan, G. Finger, M. Comin, P. Duhoux, S. Tordo, J.-L. Lizon, C. Dupuy, E. Aller-Carpentier, P. Amico, P. Haguenaer, J. Valenzuela, J.-C. Guerra, N. Hubin, L. Pasquini, B. Leibundgut

I would like also to thank our industrial partners which made our dreams possible: Microgate and ADS, REOSC, SESO, Winlight, e2v, TOPTICA and MPBC, TNO.

Any opinions, findings, and conclusions or recommendations expressed in this publication are those of the author and do not necessarily reflect the views of the European Southern Observatory.

REFERENCES

- [1] Arsenault, R., et al., "ESO Adaptive Optics Facility Progress and First Laboratory Test Results", Proc. SPIE 9148, 02 (2014)
- [2] Arsenault R., et al., "Progress on the VLT Adaptive Optics Facility", ESO Messenger No.142, p.12 (2010)
- [3] Hackenberg, W. et al., "ESO 4LGSF: integration in the VLT, commissioning and on-sky results", Proc. SPIE 9909-27 (2016)
- [4] Paufique, J., et al., "Status of the GRAAL system development: very wide-field correction with 4 laser guide-stars", Proc. SPIE 8447-116 (2012).
- [5] Paufique, J., et al., "GRAAL on the mountaintop", Proc. SPIE 9909-91 (2016).
- [6] La Penna, P., et al., "GALACSI integration and functional tests", Proc. SPIE 9148 (2014)
- [7] La Penna, P., et al., "AOF: standalone test results of GALACSI", Proc. SPIE 9909-114 (2016)
- [8] Kolb, J., et al., "Laboratory results of the AOF system testing" Proc. SPIE 9909-105 (2016)
- [9] Le Louarn, M., et al. "Comparison between simulations and lab results on the ASSIST test-bench for the AOF" Proc. SPIE 9909-277 (2016)
- [10] Oberti, S., et al., "AOF laser tomography mode: reconstruction strategy and first test results", Proc. SPIE 9909-68 (2016)
- [11] Briguglio, R., et al., "The deformable secondary mirror of VLT: final electro-mechanical and optical acceptance test results", Proc. SPIE 9148 (2014)
- [12] Stuik, R., et al., "Deploying the testbed for the VLT adaptive optics facility: ASSIST", Proc. SPIE 8447-118 (2012).
- [13] Kolb, J., et al., "Review of AO calibration, or how to best educate your AO system", Proc. SPIE 9909-20 (2016)